

E3198 i-FRAME[®]

ETFE Lined Process Pumps

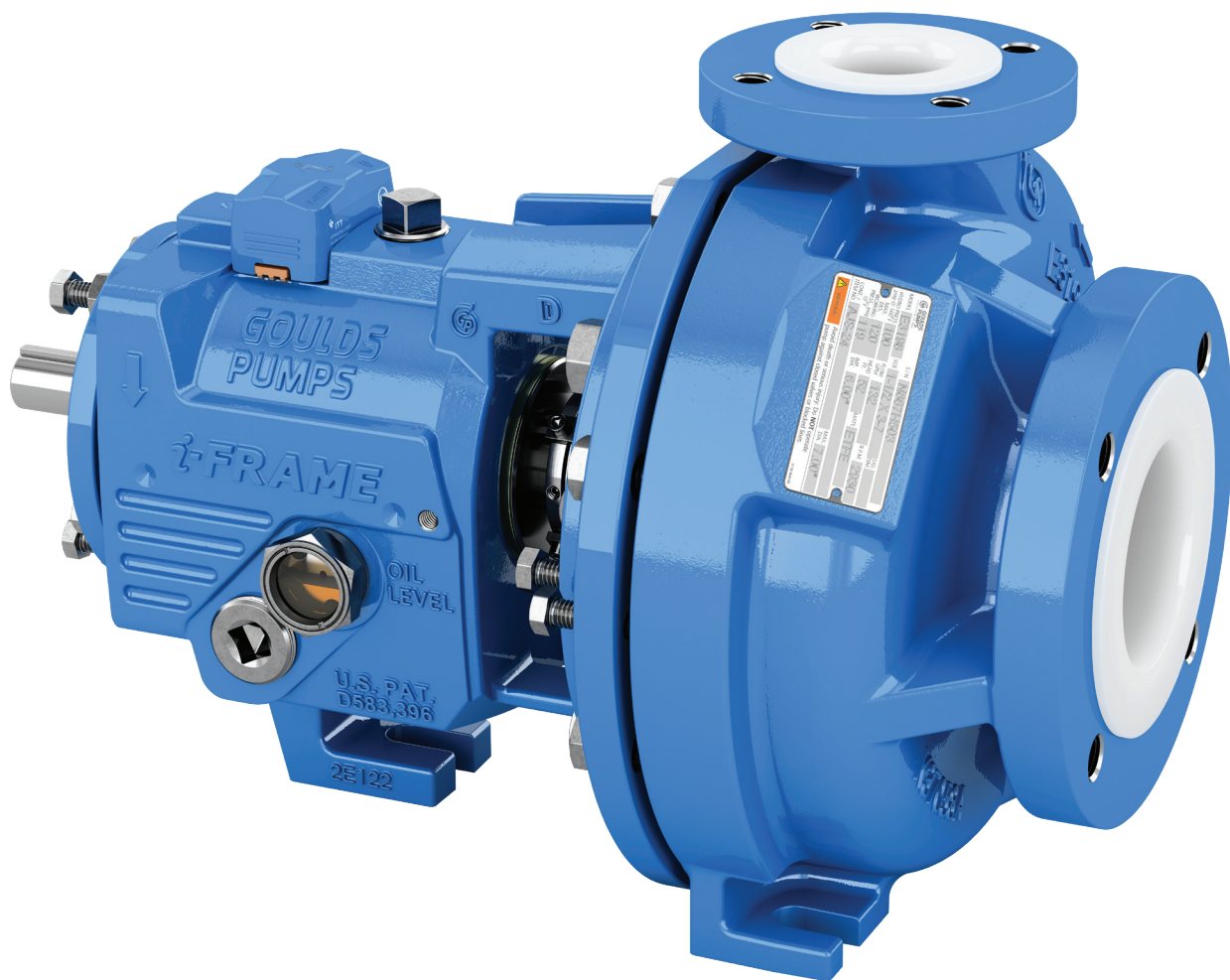

E3198 i-FRAME[®]

ETFE Lined Process Pumps Designed for Total Range of Severe Corrosive Services

- Capacities to 182 m³/h (800 GPM)
- Heads to 137 m (450 feet)
- Temperatures to 149°C (300°F)
- Pressures to 1552 kPa (225 PSIG)

Performance Features for Severe Corrosive Services

Extended Pump Life

- ETFE lining
 - Optimum lining thickness
 - Superior corrosion resistance
- i-FRAME[®] Power Ends
- Fully open PFA impeller

Ease of Maintenance

- Back pull-out design
- External impeller adjustment
- Parts interchangeable with Goulds 3196 i-FRAME[®]
- Easy retrofit
- ANSI standard dimensions

Safety

- ANSI B15.1 coupling guard
- Ductile iron frame adapter

Services

- Hydrochloric acid
- Hydrofluoric acid
- Ferric chloride
- Pickling acid
- Plating acid
- Plating solutions
- Chlorinated brine
- Chlorinated hydrocarbons
- Sodium hypochlorite
- Chlorine dioxide
- And Much More!

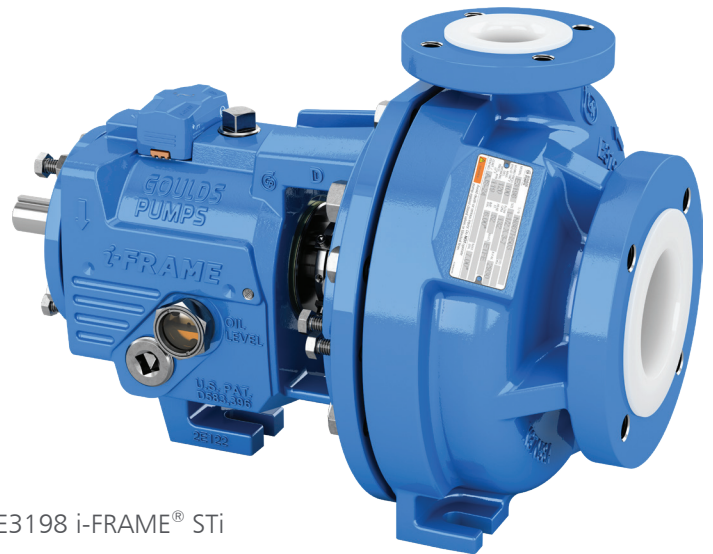

E3198 i-FRAME[®] STi

The E3198 i-FRAME[®] ETFE lined process pump line is specifically designed to provide superior performance for low flow services of the Chemical Process Industries.



E3198 i-FRAME[®] MTi

Designed for Severe Corrosive Services

An Economical Solution

For severe corrosive services, users have traditionally specified pumps constructed of exotic alloys such as titanium, zirconium, and monel. The high cost of these alloys, plus the difficulty in making the proper selection, have prompted pump users to seek alternatives.

The E3198 i-FRAME® is an economical solution. For less than the price of an exotic alloy ANSI process pump, the E3198 i-FRAME® can be reliably used for handling a wide range of severe corrosives.

The E3198 i-FRAME® is constructed for optimum reliability. Every day it proves itself in demanding installations, standing up to tough services – and lasting!



PFA Impeller



Alloy Impeller

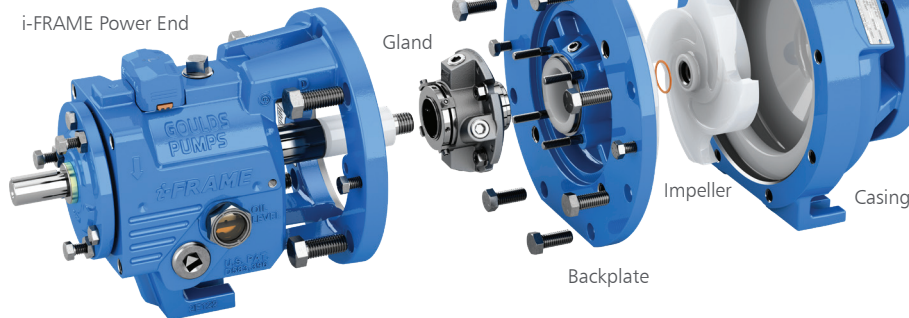

ETFE Lined Construction

Corrosion Resistance

ETFE lining is resistant to most industrial chemicals and solvents with the exception of oxidizing acids 200°F / 93°C some hot solvents and Anhydrase Bromine 150°F/65°C as well as some other uncommon chemicals. It's a material of choice for handling severe corrosives.

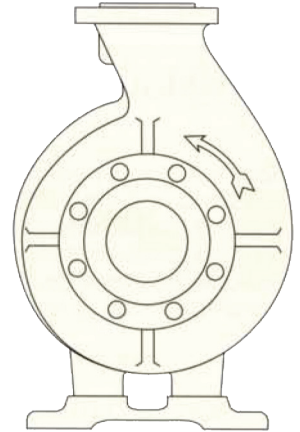

Outstanding Strength

Ductile iron and carbon steel backing provide strength equal to all-metal pump components. Outstanding strength reduces the effect of pipe loads on shaft alignment (flange loading capability is the same as all-metal 3196).

True volute casing provides performance and efficiencies similar to the standard of the industry – Goulds 3196.

Bonus Interchangeability

- i-FRAME® power ends fit 7 different process pumps.
- Minimize inventory, reduce downtime.



3196 i-FRAME®
Process Pumps



CV 3196 i-FRAME®
Non-Clog
Process Pumps



HT 3196 i-FRAME®
High Temperature
Process Pumps



LF 3196 i-FRAME®
Low Flow ANSI
Process Pumps



E3198 i-FRAME®
ETFE Lined
Process Pumps



NM 3196 i-FRAME®
Non-Metallic
Process Pumps

Maximum Sealing Flexibility

A wide range of sealing arrangements are readily available to meet specific user requirements.

Your Goulds representative can recommend the best solution for any service. Some are illustrated here.

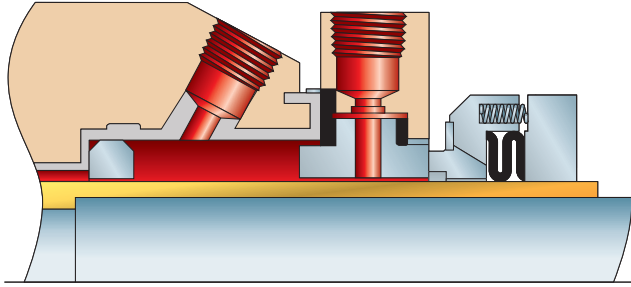

Single Outside Seal

- Stuffing box design
- Flush gland
- By-pass flush

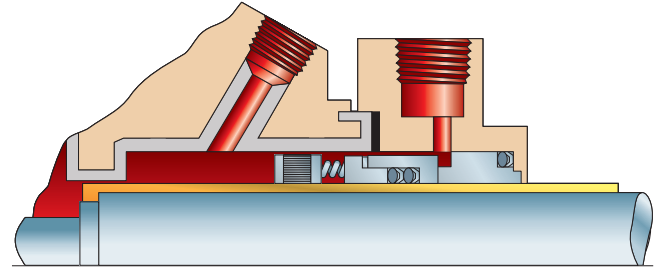

Conventional Single Seal

- Stuffing box design
- Flush gland
- By-pass flush

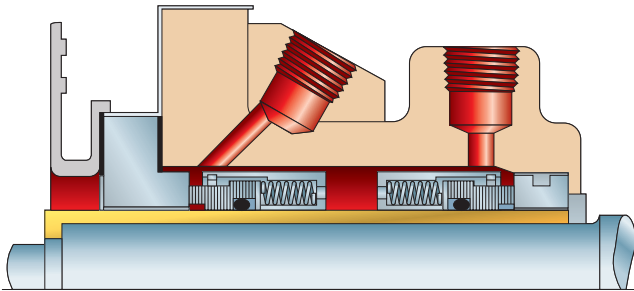

Conventional Double Seal

- Backplate design
- Seal chamber
- External flush or CPI Plan 7353

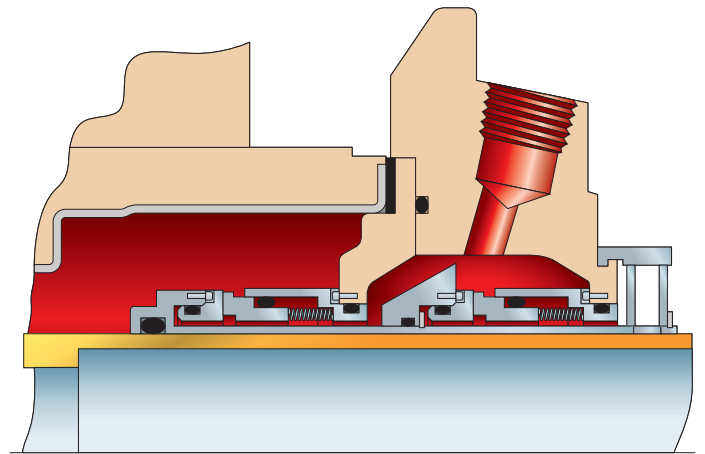

Double Cartridge Seal

- BigBore seal chamber
- Flush gland
- ETFE lined

i-FRAME Power Ends

Condition Monitor

The heart of the i-FRAME®, the optional condition monitor unit continuously measures vibration and temperature at the thrust bearing and automatically indicates when pre-set levels of vibration and temperature have been exceeded, so that changes to the process or machine can be made before failure occurs.



A visual indication of pump health makes walk-around inspections more efficient and accurate. The result is a more robust process to monitor and maintain all your ANSI pumps so that your plant profitability is maximized.

VBXX-D Hybrid Bearing Isolators

Most bearings fail before reaching their potential life. They fail for a variety of reasons, including contamination of the lubricant. VBXX-D has long been considered the industry standard in bearing lubricant protection. The i-FRAME® now improves upon that design by offering stainless steel rotors, for maximum protection against contaminants and the corrosive effects of seal leakage or environmental conditions. These seals are non-contacting and do not wear.

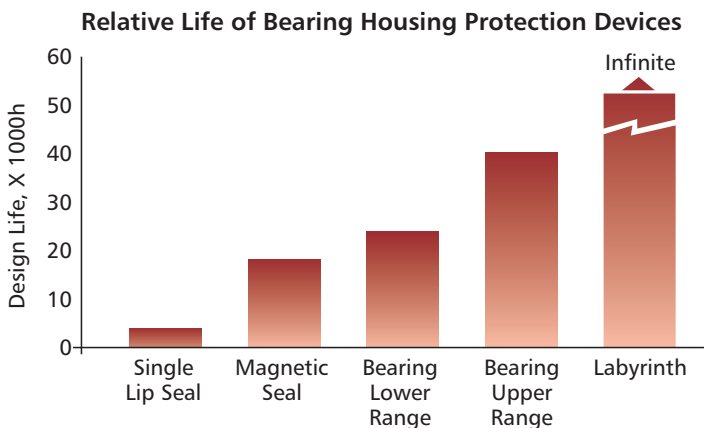
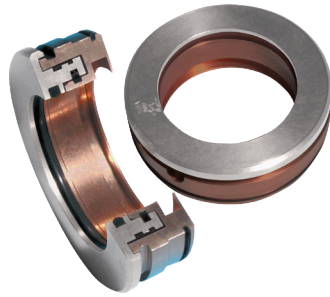

Shaft & Bearings Engineered for Maximum Reliability

Fatigue life more than double that of conventional bearing steels.

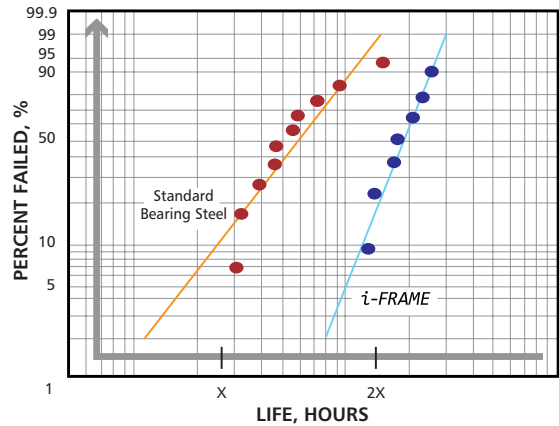
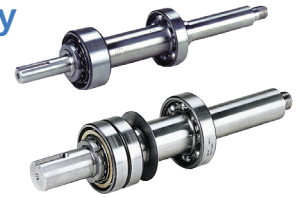

Optimized Oil Sump Design

Internal sump geometry is optimized for longer bearing life. Sump size increased by 10%-20% results in better heat transfer and cooler bearings. Contoured design directs contaminants away from bearings, to the magnetic drain plug for safe removal.

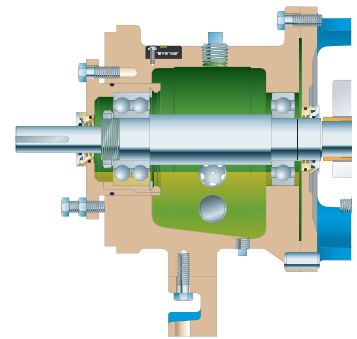

Larger Means Cooler
 GOULDS
 Industry Average

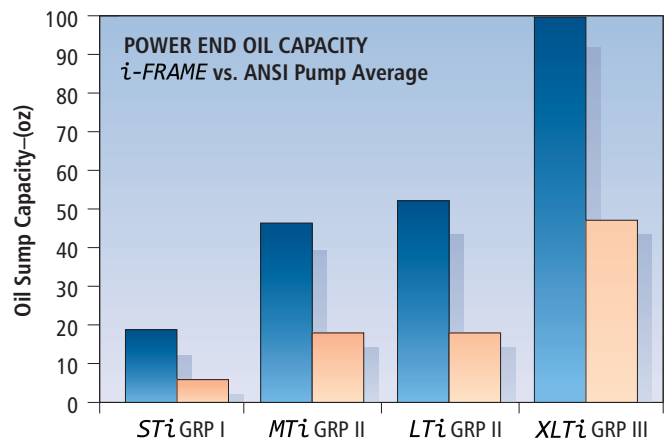

E3198 i-FRAME[®]

Design Features for Wide Range of Severe Corrosive Services

i-ALERT CONDITION MONITOR

Constantly measures vibration and temperature at the thrust bearing. Colored LED's indicate general pump health. Provides early warning of improper operation before catastrophic failure occurs.

LABYRINTH SEALS

Prevents premature bearing failure caused by lubricant contamination or loss of oil. Stainless steel rotors for optimal performance in corrosive environments.

CONTINUOUS HIGH PERFORMANCE

Original high efficiency maintained by simple external adjustment resulting in long-term energy savings.

HEAVY DUTY SHAFT AND BEARINGS

Shaft designed for minimum deflection – less than .05 mm (.002 in.) – at seal faces. Bearings sized for 2-year minimum and 10-year average life under tough operating conditions.

ONE-INCH OIL SIGHT GLASS

For easy monitoring of actual oil level and condition.

SHAFT SEALING

Goulds E3198 is available with backplate, stuffing box, or BigBore seal chamber. Accommodates conventional single inside, single outside, and double mechanical seals. BigBore seal chamber accommodates cartridge single and double seals.

RIGID FRAME (AND CASING) FEET

Reduce the effect of pipe loads on alignment.

i-FRAME POWER END

Designed for reliability and extended pump life, backed with a 5-year warranty.

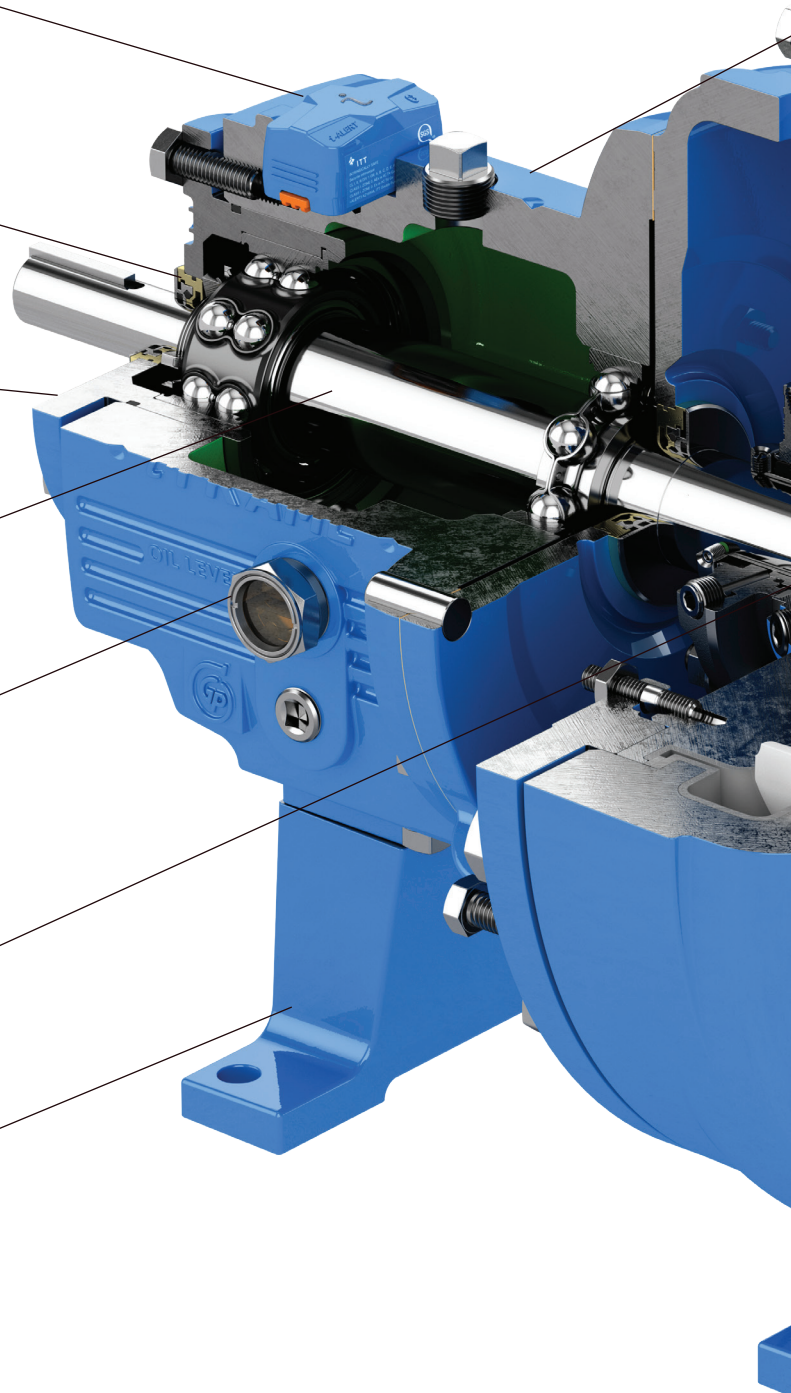

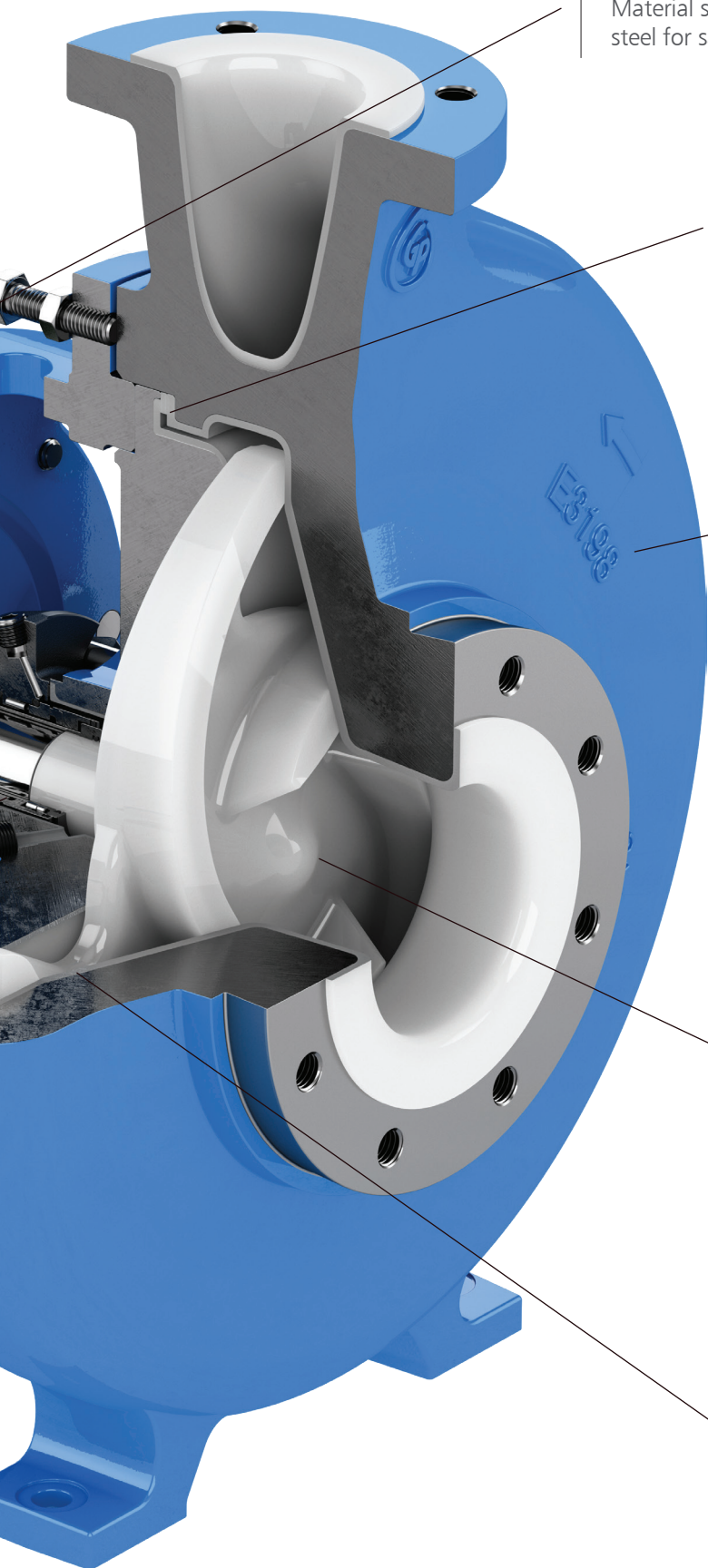

DUCTILE IRON FRAME ADAPTER

Material strength equal to carbon steel for safety.

POSITIVE SEALING

Assured by renewable, confined PTFE envelope casing gasket. Compressible filler assures positive seal with low bolt load and without need for retightening.

CIRCULATING VOLUTE CASING

Reduces radial loads during low flow operation. Mechanical seal and bearings last longer. Fully machined discharge and volute provide maximum efficiency and precise control of hydraulics at low flows.



FULLY OPEN IMPELLER

Acknowledged best design for chemical services – solids handling, stringy material, corrosives, abrasives. Back pump-out vanes minimize seal chamber pressure.

Impeller inserts provide uniform low-stress torque transfer and maximum PFA material support. Assures close tolerance impeller-to-shaft alignment and fit. Metal-to-metal impeller drive.

PFA Impeller O-ring in controlled compression protects threaded area against corrosion.

ETFE

Rotolined to ductile iron. Provides improved adhesion hardness and toughness. No dove tails needed. ETFE resists abrasions and permeation.

Hydraulic Coverage

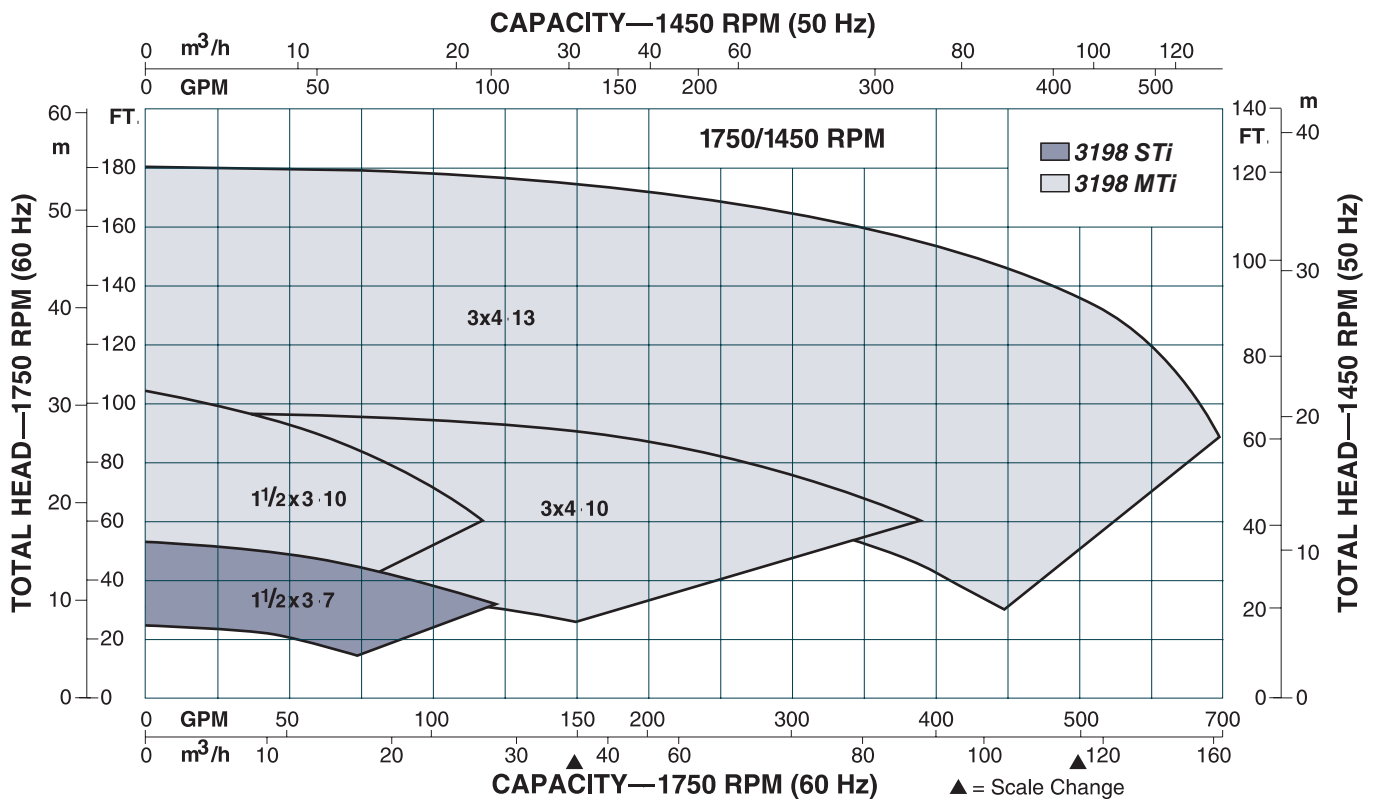
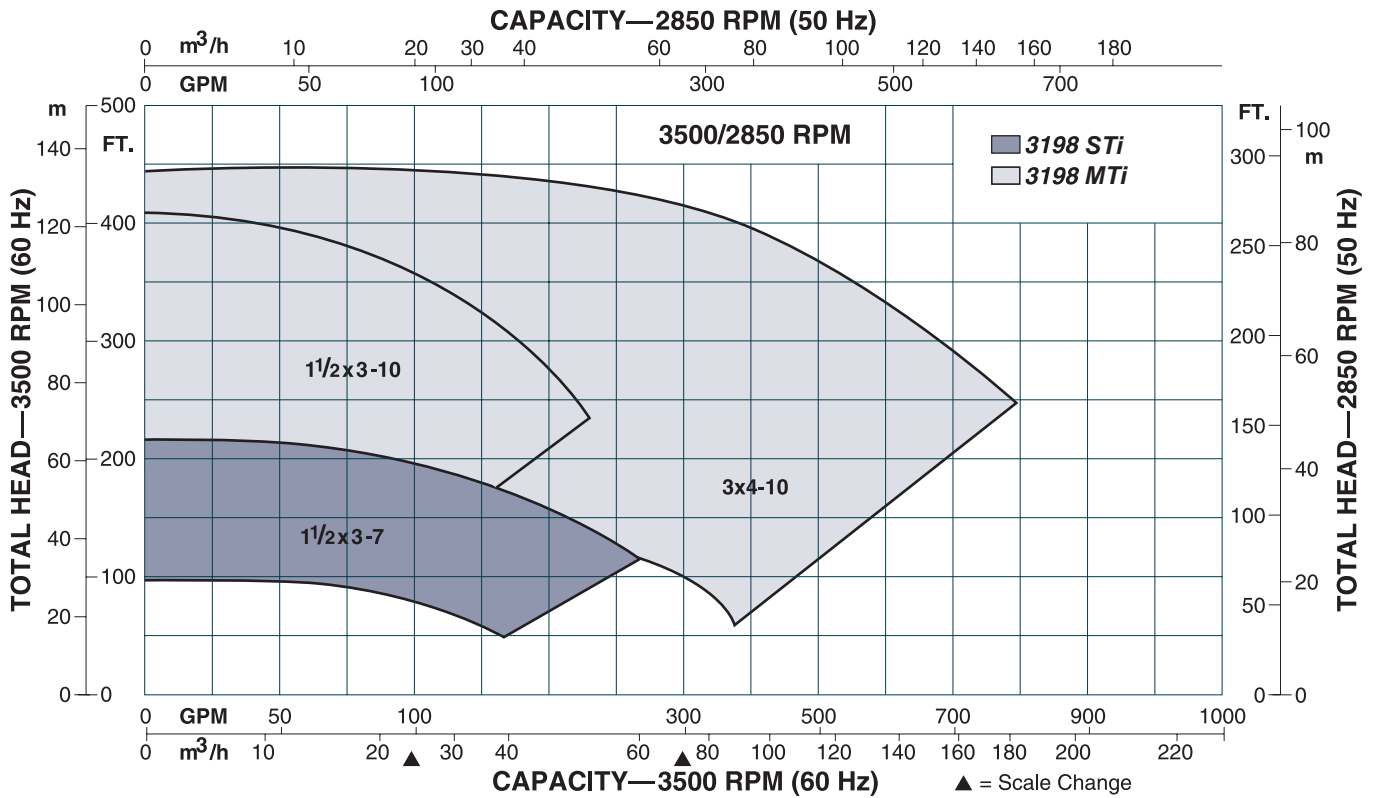

Parts List and Materials of Construction

Item Number	Part Name	Material
100	Casing	ETFE Lined Ductile Iron
101	Impeller (with insert)	PFA Lined Steel
108	Frame Adapter	Ductile Iron
112	Thrust Bearing	Double Row Angular Contact
122	Shaft	316SS (Standard) Optional: Alloy 20, Hastelloy B & C
126	Shaft Sleeve	Choice: PTFE, 316SS, Alloy 20, Hastelloy, B & C, Titanium, Zirconium
136	Bearing Locknut and Washer	Steel
159	Seal Chamber (Backplate Design)	316SS
168	Radial Bearing	Single Row Deep Groove
228	Bearing Frame	Cast Iron (Ductile Iron for STi)
319	Oil Sight Glass	Glass/Steel
332A	Labyrinth Seal (Outboard)	Stainless Steel/Bronze
333A	Labyrinth Seal (Inboard)	Stainless Steel/Bronze
351	Casing Gasket	PTFE Envelope
356A	Stud – Casing to Frame or Frame Adapter	316SS
360	Gasket-Frame to Adapter	Buna Rubber
370H	Stud and Nut – Backplate/Frame or Frame Adapter	304SS
383	Mechanical Seal	(As Specified)
418	Jacking Bolt	304SS
444	Backplate	ETFE Lined Ductile Iron
469B	Dowel Pin	Steel
496	O-ring – Bearing Housing	Buna Rubber
496A	O-ring – Impeller	PTFE
761B	Condition Monitor	Electronic Assg.

Construction Details

All dimensions in inches and (mm)

		E3198 STi	E3198 MTi
Lining Thickness	Casing	1/8 (3.2)	
	Impeller	1/8 (3.2)	
	Stuffing Box Cover	1/8 (3.2)	
	Backplate	1/8 (3.2)	
	Shaft Sleeve	1/8 (3.2)	
Shaft	Diameter at Impeller	.75 (19)	1 (25)
	Diameter in Seal Chamber (Less Sleeve)	1.375 (35)	1.75 (45)
	(With Sleeve)	1.125 (29)	1.5 (38)
	Diameter Between Bearings	1 1/2 (38.1)	2 1/8 (54)
	Diameter at Coupling	7/8 (22.2)	1 1/8 (28.6)
	Overhang	6.125 (156)	8.375 (213)
	Maximum Shaft Deflection	0.002 (0.05)	
Sleeve	Outer Diameter thru Seal Chamber	1 3/8 (34.9)	1 3/4 (44.5)
Bearings	Radial	6207	6309
	Thrust	3306	3309 A/C3
	Bearing Span	4.125 (105)	6.75 (171)
Seal Chamber	Bore	2.1 (53)	2.6 (66)
Power Limits	HP (kW) per 100 RPM	1.1 (.82)	3.4 (2.6)
Maximum Liquid Temperature	Oil/Grease Lubrication	300°F (150°C)	

Sectional View

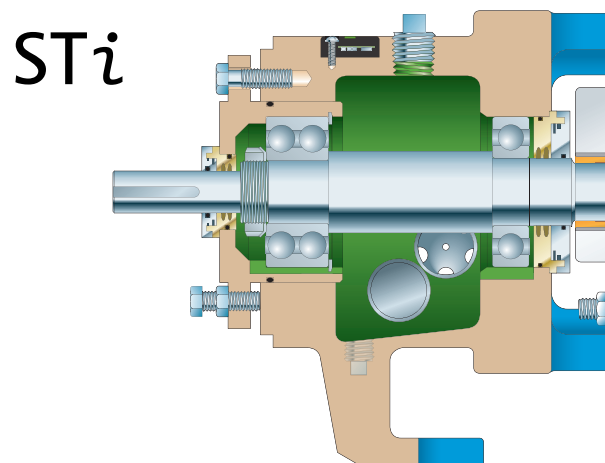
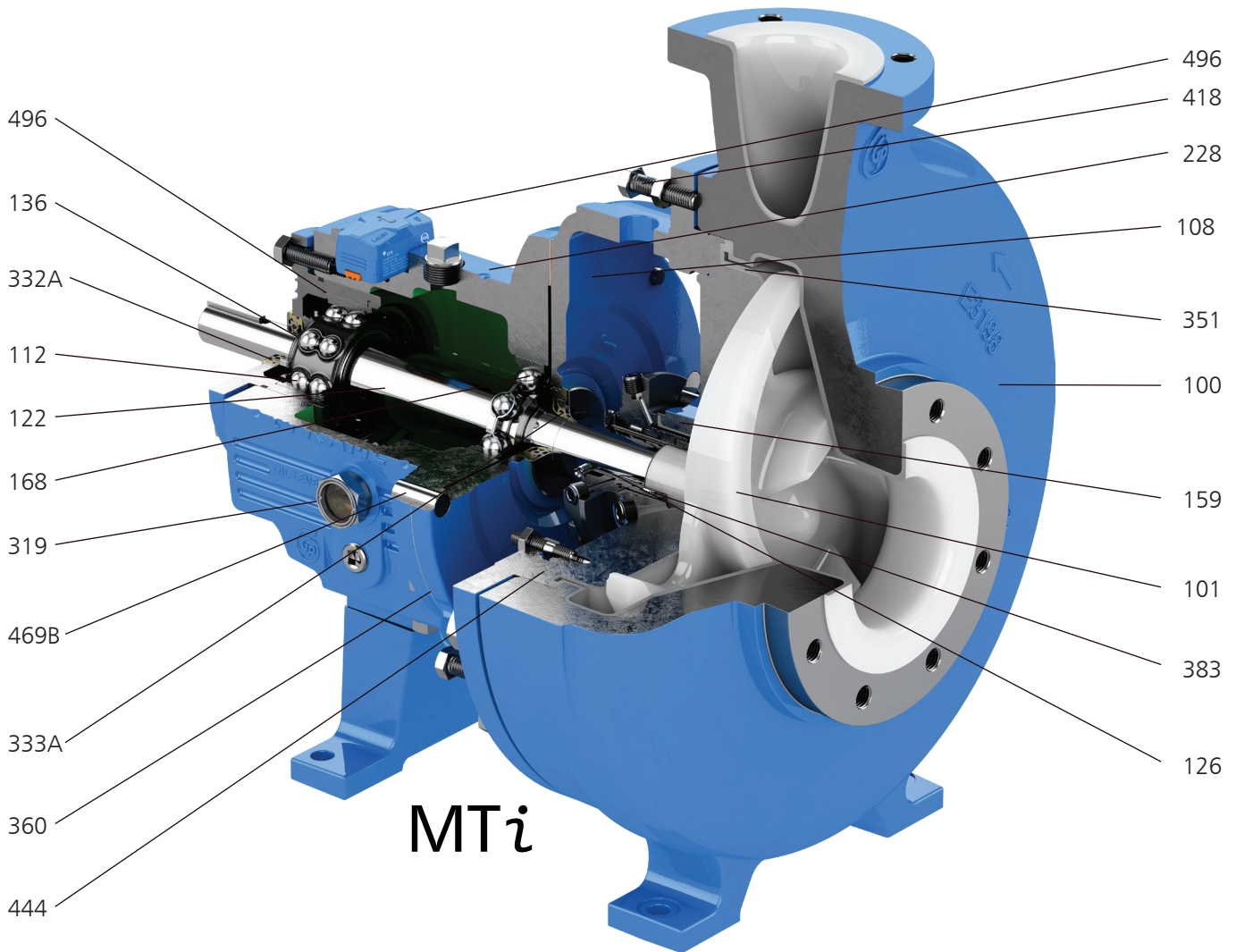

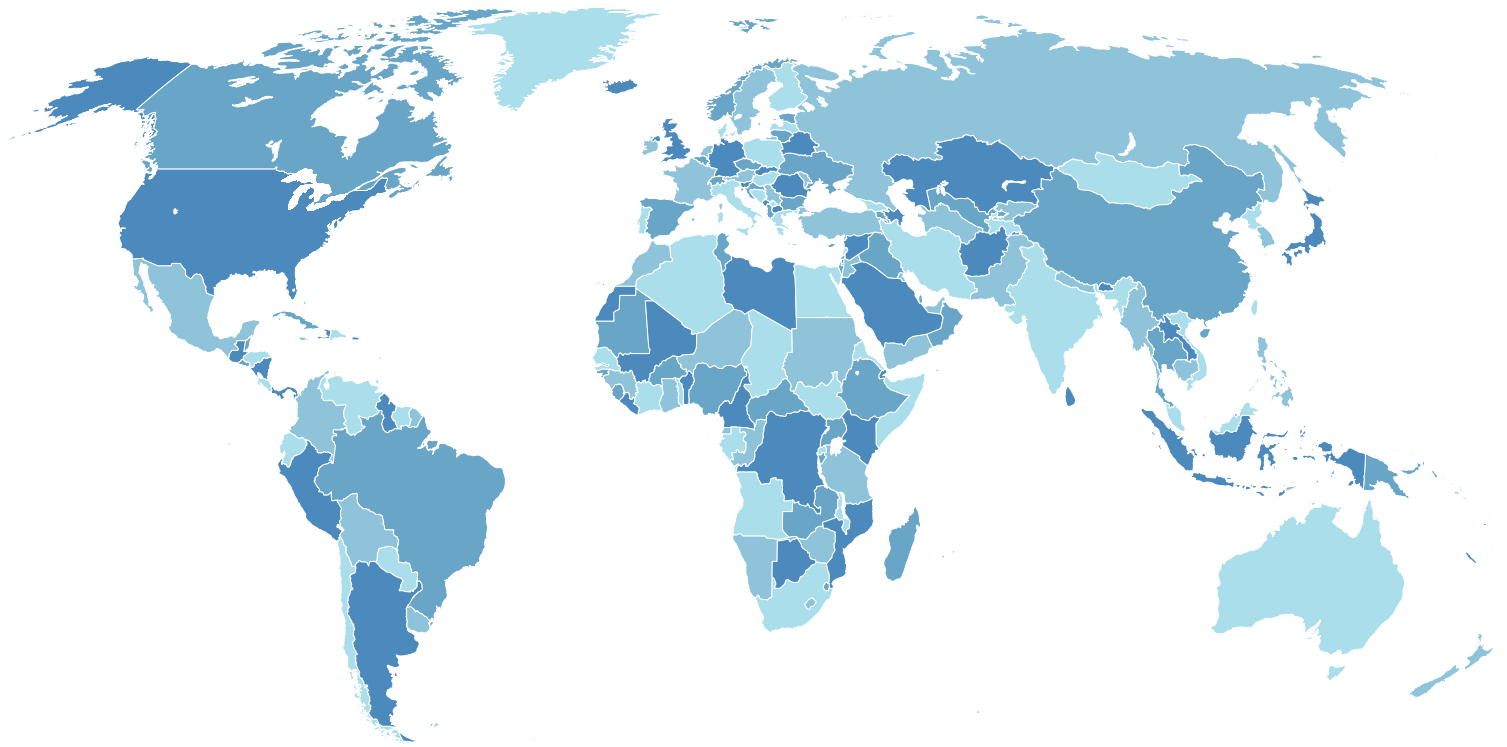

Visit www.ittproservices.com & www.gouldspumps.com to find nearest service, sales, and manufacturing locations



— An ITT Brand

240 Fall Street

Seneca Falls, NY 13148

Phone: 315.568.2811

Fax: 315.568.2418

www.gouldspumps.com

© 2024 ITT Goulds Pumps Inc.

B.E3198.en-US.2024-05