

3296 EZMAG

Chemical Process Pump



3296 EZMAG

- Chemical Process Pump
- Capacities to 700 gpm (160 m³/h)
- Heads to 620 ft (189 m)
- Temperatures to 535°F (280°C)
- Pressures to 275 PSIG

Performance Features

Extended Pump Life

- Sealless design
- Enclosed impeller
- Silicon carbide radial and thrust bearings
- Optional Dryguard™ bearings for dry run protection
- Reliable flush circuit

Ease of Maintenance

- Bearing Cartridge design
- Double-back pull-out
- Close coupled option on S group
- ANSI B73.1 dimensional standards
- No mechanical seal
- Minimum number of parts

Safety

- Zero emissions
- One-piece Hastelloy C containment shell
- Drive and driven magnet clearances protect containment shell
- Bearing Cartridge design contains bearings in case of failure
- Adapter drain connection
- Optional casing drain

Services:

- Nitric Acid
- Heat Transfer Fluids
- Methylene Chloride
- Caustic
- Butadiene

Applications:

- Batch chemical process
- Rail car or tank unloading
- Specialty chemicals



3296 EZMAG Frame Mounted Design



3296 EZMAG Close Coupled Design (S Group Only)

Reliable, Simple, and EZ to Maintain

Bearing Cartridge

Individual bearings are contained in a single cartridge assembly.

- Bearings are made of highly abrasion- and corrosion-resistant silicon carbide. Dryguard™ bearings are available for protection against occasional dry run conditions.
- In the event of bearing failure, the cartridge design contains the bearings and prevents further damage to pump internals.
- Installation and replacement of bearings is simple. Only one component to install.



Containment Shell

The containment shell is the most important component isolating the pumpage from the atmosphere.

- The containment shell is a deep-drawn single piece design made from Hastelloy C for reliable corrosion resistance.
- The vortex-breaking bead at the bottom of the can prevents erosion.
- Burst pressure is greater than 2,175 psi.



Maintenance Made Simple

The 3296 EZMAG was designed with the end user in mind.

Fewer parts make planned maintenance faster and easier than other sealless and sealed process pumps. The S group is also available in a close-coupled configuration, further eliminating the need for time-consuming pump and motor alignment.



3296 EZMAG Options

Inducer

An optional inducer can reduce the NPSHr by as much as 35-50%. This can allow smaller pumps to operate at higher speeds resulting in lower installation costs. Great for media with low NPSHa, high vapor pressures or entrained air.

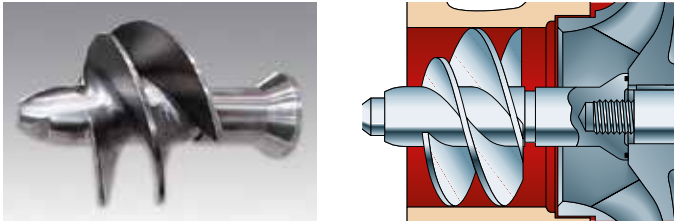

Dryguard™ Bearings

The heat generation from dry run conditions is the number one mode of failure for sealless pumps. Dryguard™ is a diamond-like carbon that reduces the coefficient of friction by over 70%, enabling short periods of safe operation under dry run conditions. Dryguard™ is up to 2X harder than silicon carbide, ensuring its benefits cannot be compromised in even the harshest conditions.



High Temperature Applications

The 3296 EZMAG is ideal for applications up to 535°F. For fluids between 350°F and 535°F, special design considerations are incorporated. A "High Temperature" bearing cartridge is used to handle the additional rate of thermal expansion. Secondly, Samarium Cobalt magnets are used to ensure performance at elevated temperatures.



3296 EZMAG

Reliable Recirculation

Simple, Reliable Recirculation Circuit

The 3296 EZMAG's reliable flush circuit features patented geometry to ensure the bearings receive proper lubrication. Axial vanes on the driven magnet move fluid around the back of the containment shell. Spiral grooves in the bearing cartridge transport fluid through the cartridge and back into the casing. Bearings stay lubricated and heat resulting from eddy current losses is carried away.

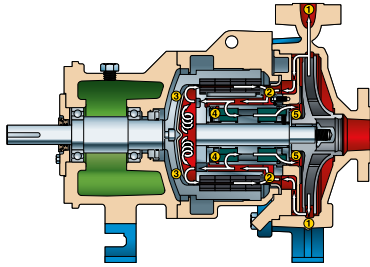

Optional Features: Condition Monitoring

RTD or Thermocouple

Monitors containment shell temperature, provides basic pump protection by indicating system malfunctions such as dry-run conditions, plugged recirculation, flashing of pumpage or decoupling of magnets.



Temperature Controller

Used to measure signal from containment shell temperature sensor. Has adjustable trip point to sound alarm and/or stop the pump.



Power Monitoring

The PS10 and PS20 Pump Load Monitors measure the motor input power in combination with a proprietary algorithm to accurately determine the pump's power draw. The devices can be set to automatically shut down the pump or warn the operator when upset conditions occur, protecting the pump from damage.



Other Goulds Sealless Process Pumps

Model 3298/3299

Fluoropolymer-lined to handle severe corrosives. Lined pumps provide cost-effective solutions when handling corrosives requiring high alloys. These models feature non-metallic containment shells which eliminate eddy current losses.

Model SP3298

When suction pressure is negative and air or gases must be evacuated to accomplish pump priming, the SP3298 has a self-priming dual volute that primes on demand with only an initial charge of liquid in the casing. Priming is accomplished within the casing, eliminating the need for auxiliary priming systems. Maximum component interchangeability with 3298.

Model V3298

In-line design requires minimal floor space and provides reduced installation costs. Installation is simple because the unit is mounted directly in the line, like a valve. This eliminates the need for field alignment. Maximum component interchangeability with the model 3298.



3296 EZMAG Options

Design Features for Maximum Reliability

LABYRINTH OIL SEAL

Prevents premature bearing failure caused by lubricant contamination and loss of oil.

CAST IRON BEARING FRAME

Ideal construction for safety and strength. Flood oil lubrication standard, regreaseable bearings optional. Close coupled design is also an option on S Group sizes.

OIL SIGHT GLASS

For easy monitoring of actual oil level and condition. Bottle oiler is optional.

CONTAINMENT SHELL

Hastelloy C construction for superior corrosion resistance, high strength, minimal eddy current losses. Deep drawn (one piece) shell for safe, reliable operation.

SIMPLIFIED ASSEMBLY AND DISASSEMBLY

- The number of "loose" components has been minimized due to its modular design concept.
- High component interchangeability within the frame size groups.
- No special tools required.
- No fitting measurements.
- Back pull-out design allows for maintenance of the drive side while keeping the liquid end assembled and pressurized.

HEAVY DUTY CASING

- ANSI dimensional
- 1/8" corrosion allowance
- Optional tapped connections

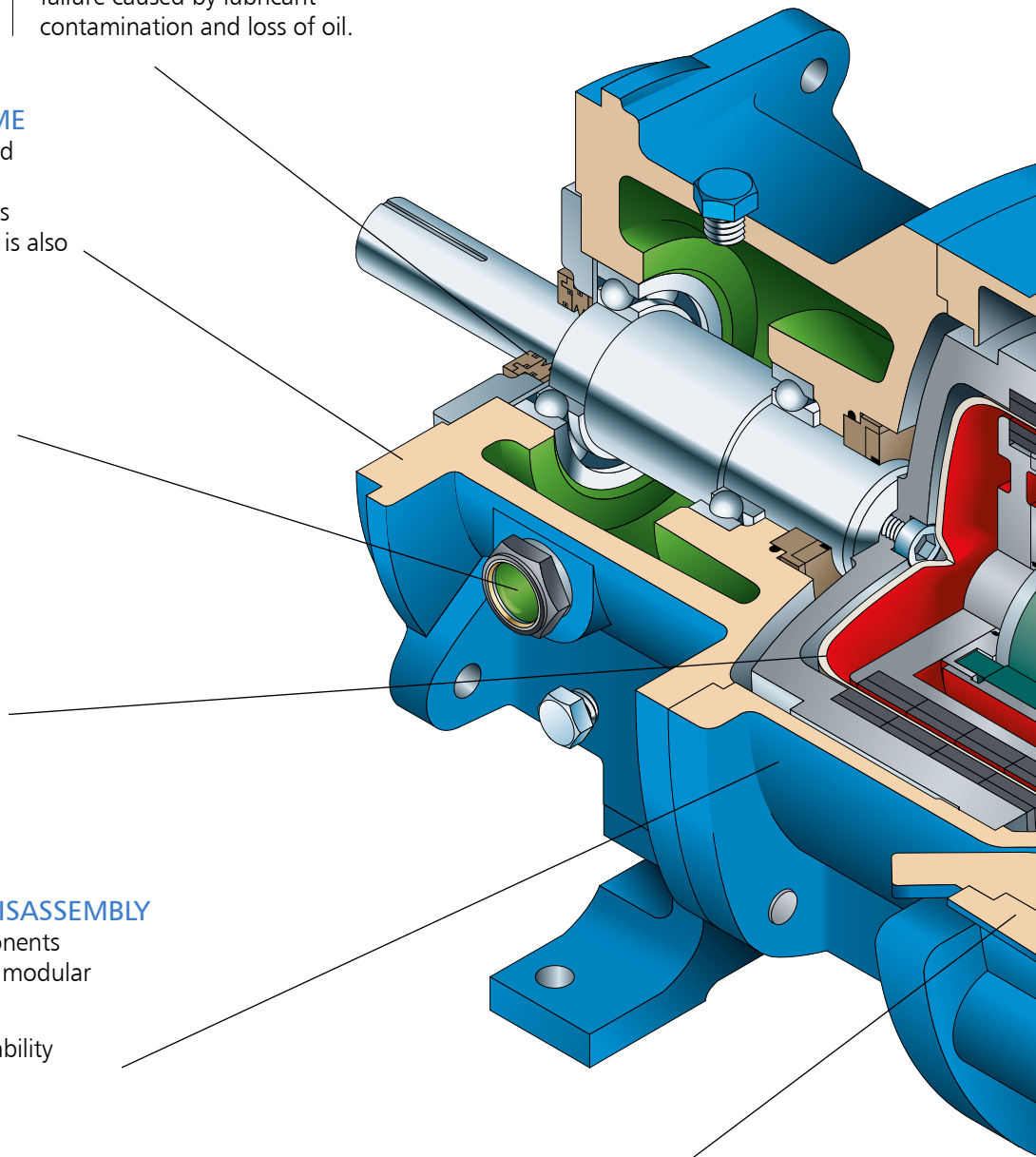

RARE EARTH MAGNETS

Neodymium Iron standard. Optional Samarium Cobalt for higher temperatures. Rare earth material provides high torque capability.

BEARING CARTRIDGE

- Standard pure Silicon Carbide, highly abrasion-resistant with universal chemical resistance.
- Cartridge design eliminates measurements and fitting for simplified maintenance.
- Optional Dryguard™ bearing enables safe operation in temporary dry run conditions.
- High temperature cartridge is also available.
- Protects pump internals in the event of a bearing failure.

PRESSURIZED RECIRCULATION

Dual path internal recirculation prevents vaporization of product in circuit. Ensures lubrication of bearings and continuous cooling of containment shell.

ENCLOSED IMPELLER

Positively keyed and locked to shaft prevents catastrophic failure due to reverse rotation. Designed for minimum axial thrust, extended thrust bearing life.

OPTIONAL INDUCER

- Reduces the NPSHr by 35–50%.
- Permits smaller pumps at higher speeds = lower costs.
- Is advantageous for media with gas content.

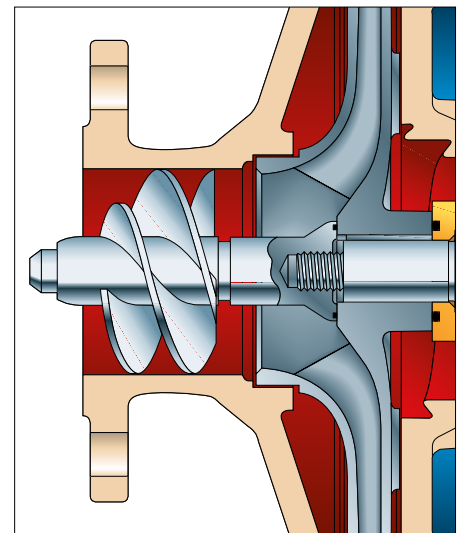
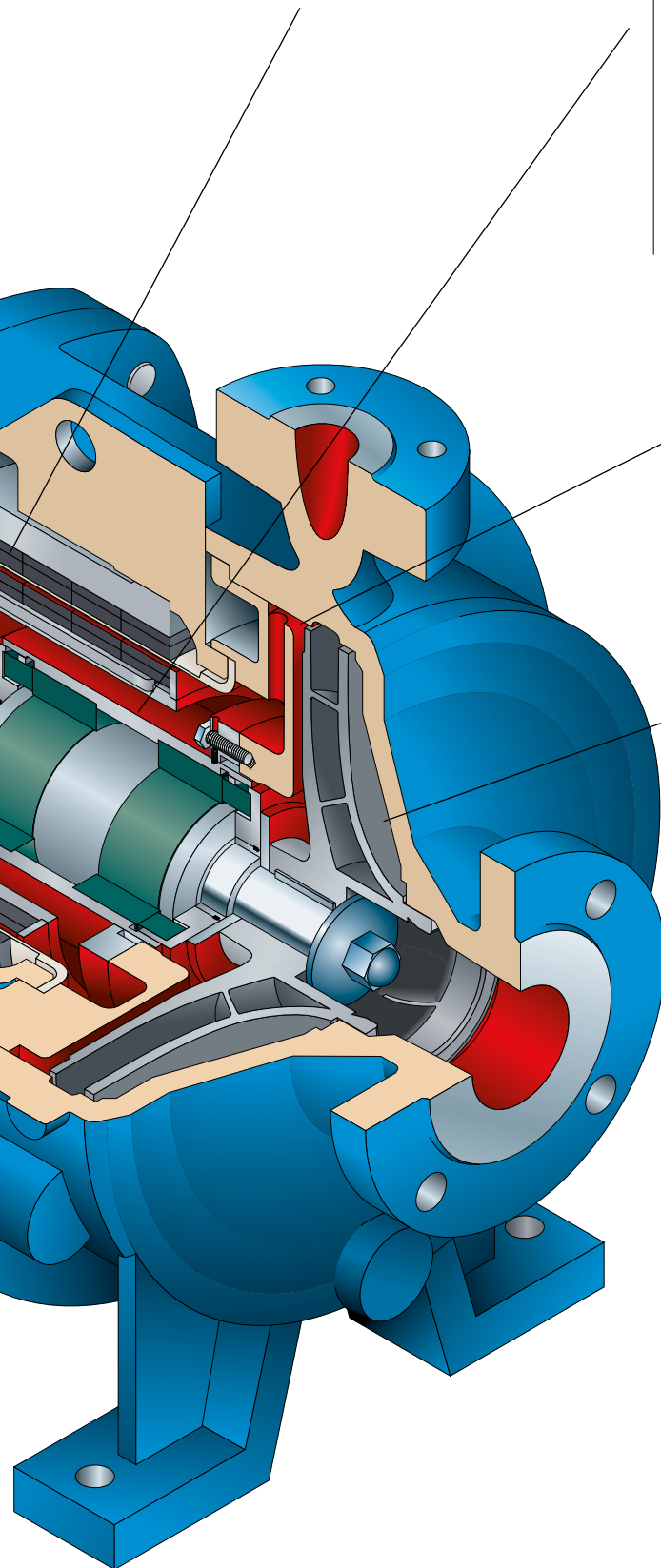

Parts List and Materials of Construction

Number	Description	Material	
		Stainless	Hastelloy C
100	Casing	Stainless Steel	Hastelloy C
101	Impeller	Stainless Steel	Hastelloy C
108	Frame Adapter	Ductile Iron	Ductile Iron
109A ²	End Cover	Ductile Iron	Ductile Iron
112 ²	Ball Bearing	Steel	Steel
113A ²	Plug, Pipe Fill	Steel	Steel
122A ¹	Stub Shaft	Steel	Steel
122B ²	Drive Shaft	Steel 4140	Steel 4140
178	Impeller Key	303SS	Hastelloy C
199	Washer, Distance	Stainless Steel	Hastelloy C
222E ³	Set Screw (backplate to adapter)	Stainless Steel	Stainless Steel
222L ¹	Set Screw (stub shaft to motor)	Steel	Steel
228 ²	Bearing Frame	Cast Iron	Cast Iron
241 ⁴	Foot, Frame	Cast Iron	Cast Iron
304	Impeller Nut	Stainless Steel	Hastelloy C
319 ²	Sight Window	Steel/Glass	Steel/Glass
332A ²	Labyrinth Oil Seal – outboard	Bronze	Bronze
333D ^{2, 5}	Labyrinth Oil Seal – inboard	Bronze	Bronze
351X	Gasket, Intermediate Ring	PTFE (Glass Filled)	PTFE (Glass Filled)
351 ⁶	Gasket (backplate to casing)	Aramid Fiber EPDM	Aramid Fiber EPDM
360A	Gasket (endcover)	Vellumoid	Vellumoid
360W	Gasket (frame to adapter)	Aramid Fiber EPDM	Aramid Fiber EPDM
370	Hex Cap Screw (adapter to casing)	Stainless Steel	Stainless Steel
370B	Hex Cap Screw (frame to adapter)	Steel	Steel
370C ²	Hex Cap Screw (end cover)	Steel	Steel
370F ⁴	Hex Cap Screw (foot to frame)	Steel	Steel
370V	Hex Cap Screw (backplate to adapter)	Stainless Steel	Stainless Steel
371 ¹	Hex Cap Screw (motor to adapter)	Steel	Steel
382	Lockwasher	Steel	Steel
400 ²	Key, Square	Steel	Steel
408A ²	Plug, Drain	Steel	Steel
408J ²	Plug, Oiler	Steel	Steel
412A	Impeller Nut O-ring	PTFE	PTFE
444	Backplate	Stainless Steel	Hastelloy C
445A	Pin (backplate to cartridge)	303SS	Hastelloy C
503 ¹	Adapter, Close Coupled	Cast Iron	Cast Iron
504 ¹	Adapter, Ring (280 NEMA C-face motors)	Steel	Steel
529 ²	Washer, Wave	Steel	Steel
540N ⁶	Gasket, Containment Shell	Aramid Fiber EPDM	Aramid Fiber EPDM
740A	Driven Carrier/Shaft Assembly	Duplex SS/NdFeB	Hastelloy C/NdFeB
740B	Drive Carrier Assembly	Ductile Iron/NdFeB	Ductile Iron/NdFeB
750	Containment Shell	Hastelloy C	Hastelloy C
791D	Socket Head Screw (carrier)	Steel	Steel
791E	Hex Cap Screw (cartridge to backplate)	Stainless Steel	Hastelloy C
849	Bearing Cartridge	Duplex SS/Silicon Carbide	Hastelloy C/Silicon Carbide

¹ Close Coupled Configuration Only

² Frame Configuration Only

³ 6" S Group Only

⁴ M Group Frame Configuration Only

⁵ Carbon-Filled PTFE for S Group Only

⁶ Optional Gasket Materials: White Gylon and Fawn Gylon

Interchangeability Chart

Frame-Mounted Units

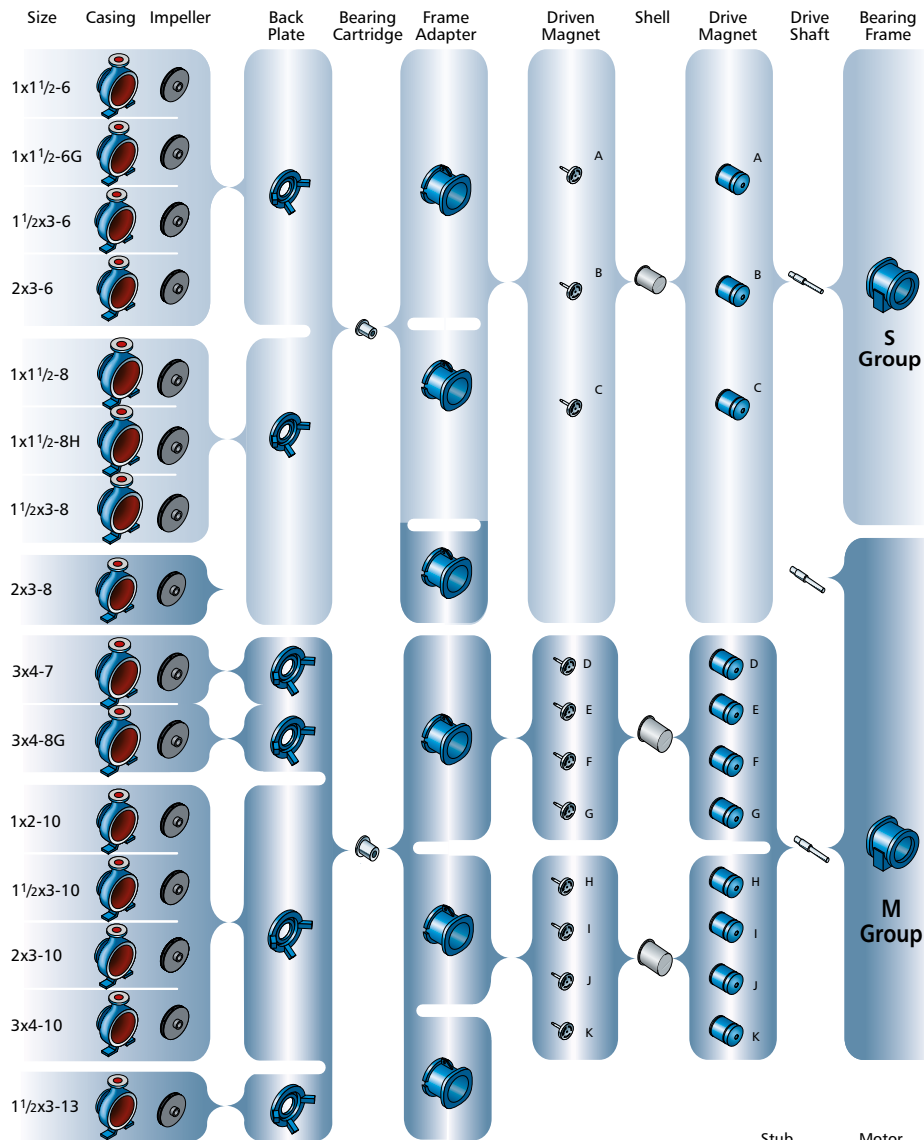

Close Coupled Units

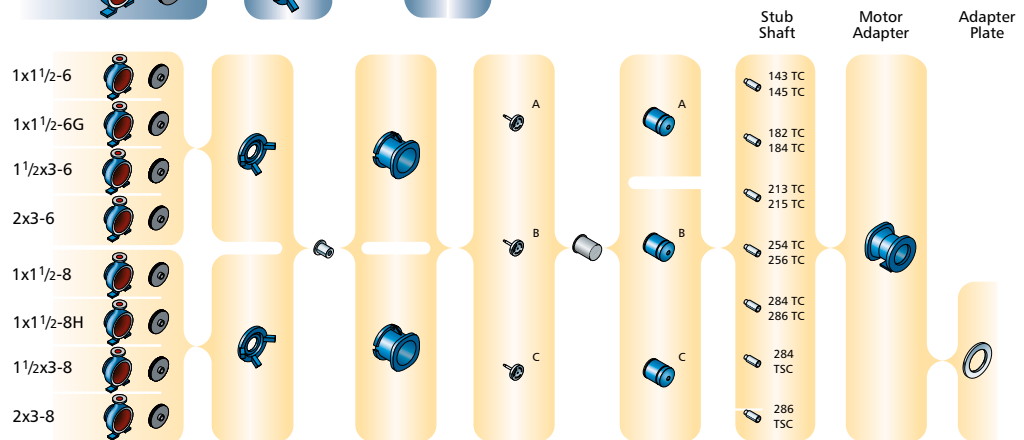

Hydraulic Coverage

3600/2900 RPM

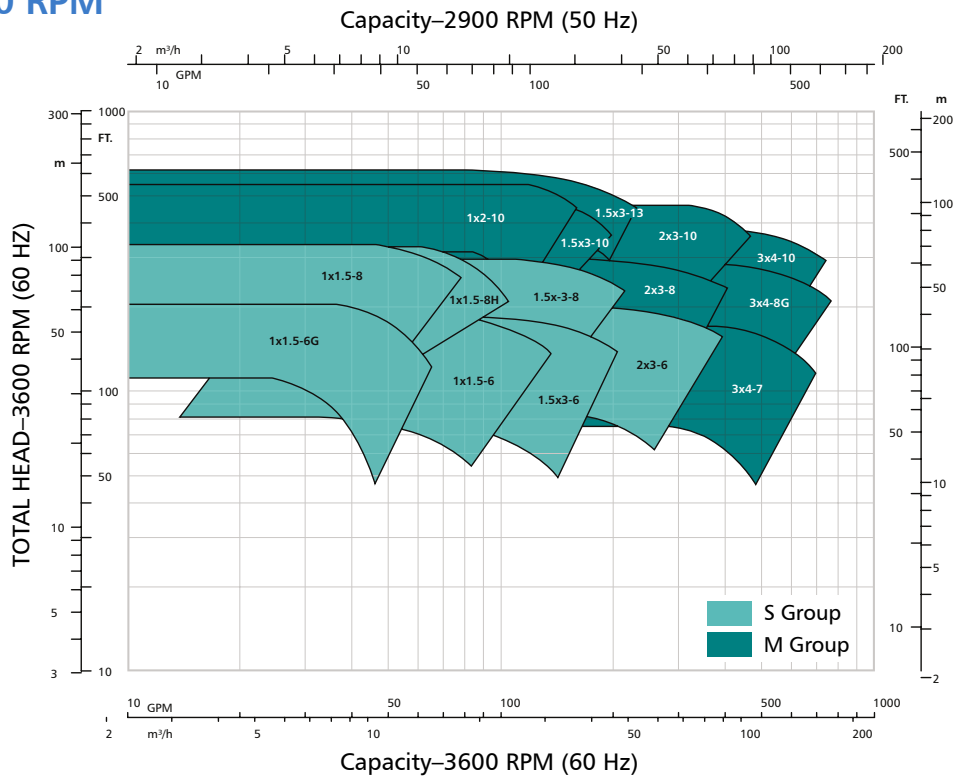

1800/1450 RPM

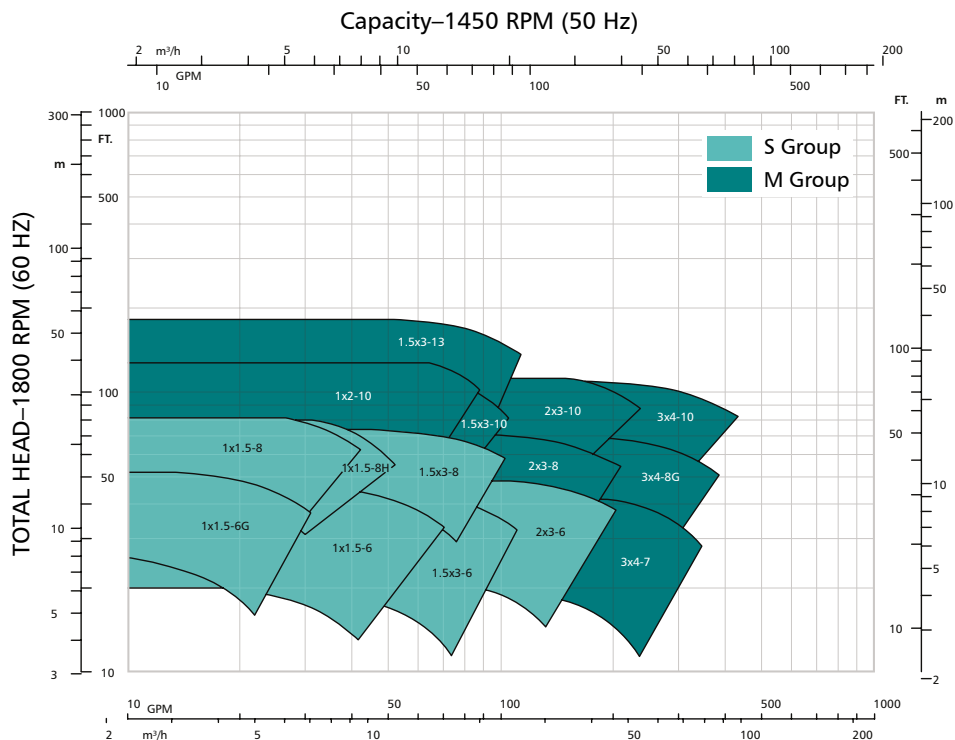

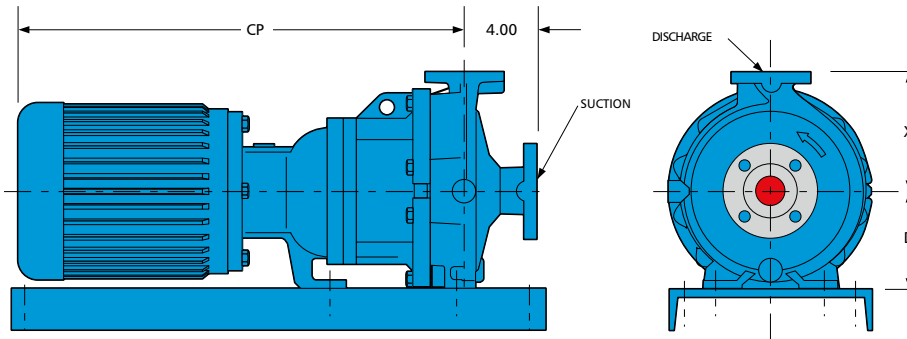

Frame-Mounted Design

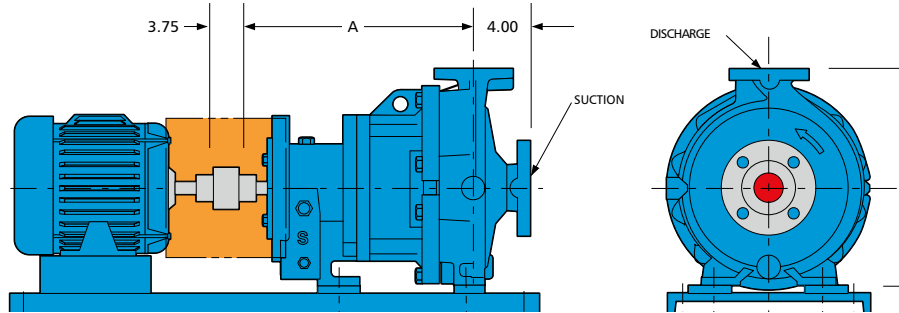

*Not to be used for construction.

BARE PUMP DIMENSIONS						
Group	Pump Size	A in (mm)	D in (mm)	X in (mm)	Close-Coupled Pump Weight lb (kg)	Frame-Mounted Pump Weight lb (kg)
S	1x1½-6	13.5 (343)	5.25 (133)	6.5 (165)	112 (51)	133 (60.5)
	1x1½-6G	13.5 (343)	5.25 (133)	6.5 (165)	114 (52)	135 (61)
	1½x3-6	13.5 (343)	5.25 (133)	6.5 (165)	119 (54)	136 (61.5)
	2x3-6	13.5 (343)	5.25 (133)	6.5 (165)	140 (63.5)	142 (64.5)
	1x1½-8	13.5 (343)	5.25 (133)	6.5 (165)	133 (60.5)	144 (65.5)
	1x1½-8H	13.5 (343)	5.25 (133)	6.5 (165)	131 (59.5)	142 (64.5)
	1½x3-8	13.5 (343)	5.25 (133)	6.5 (165)	148 (67)	154 (70)
S/M	2x3-8	19.5 (495)	8.25 (210)	9.5 (242)	153 (69.5)	158 (71.5)
8"M	3x4-7	19.5 (495)	8.25 (210)	11 (280)	NA	244 (110.5)
	3x4-8G	19.5 (495)	8.25 (210)	11 (280)	NA	255 (115.5)
10"M	1x2-10	19.5 (495)	8.25 (210)	8.5 (216)	NA	271 (123)
	1½x3-10	19.5 (495)	8.25 (210)	8.5 (216)	NA	277 (126)
	2x3-10	19.5 (495)	8.25 (210)	9.5 (242)	NA	276 (125)
	3x4-10	19.5 (495)	8.25 (210)	11 (280)	NA	300 (136)
13"M	1½x3-13	19.5 (495)	10.00 (254)	10.5 (267)	NA	312 (141.5)

S GROUP CLOSE COUPLED	
Motor Frame	CP Approx. in (mm)
143TC	25 (635)
145TC	24 (610)
182TC/184TC	26 (660)
213TC/215TC	29.5 (749)
254TC/256TC	34 (864)
284TC	36 (914)
284TSC	34 (864)
286TC	37.5 (953)
286TSC	34 (864)



An ITT Brand

240 Fall Street
 Seneca Falls, NY 13148
 Phone: 315.568.2811
 Fax: 315.568.2418
 www.gouldspumps.com

© 2025 ITT Goulds Pumps Inc.

B.3296EZMAG.en-US.2025-01