

3171

Vertical Sump Pumps



3171

Goulds Model 3171

Vertical Sump Pumps Designed for the Total Range of Industry Services

- Capacities to 3,180 GPM (722 m³/h)
- Heads to 344 feet (105 m)
- Temperatures to 450° F (232° C)
- Pit Depths to 20 feet (6 m)

Design Features

- Self-Priming
- Rugged Double Row Thrust Bearing
- Heavy Duty One-Piece Shaft
- External Impeller Adjustment
- Available in a Wide Range of Alloys
- Open Impeller Design
- Vapor Proof Option: Choice of packing, or mechanical seal for containing sump vapors

Services

- Industrial Process
- Industrial Sump Wastes
- Molten Sulfur
- Tank Unloading
- Corrosive and Non-Corrosive Liquids



The "Veteran" vertical sump and process pump. Thousands of installations – industrial process, sump drainage, corrosive liquids, pollution control, molten sulfur – attest to the 3171's remarkable performance. Simple mounting.

3171 Vertical Sump and Process Pumps

Heavy Duty Design Features for a Wide Range of Services.

LABYRINTH BEARING SEAL

Prevents premature bearing failure due to lubricant contamination

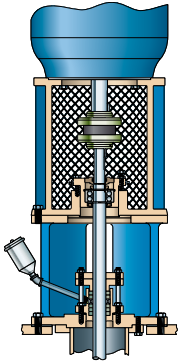

OPTIONAL UPPER STUFFING BOX

HEAVY COLUMN PIPE

Provides rigid support for pump and bearings

LINESHAFT STEADY BEARING

Self-lubricating carbon / graphite bearing furnished as standard – best for handling water, corrosives, solvents and high temperature liquids

RESTRICTOR BUSHING

Close running bushing to prevent pressure loss from casing



FULLY OPEN IMPELLER WITH BACK PUMP-OUT VANES

Acknowledged best design for process services – solids handling, stringy material, corrosives, abrasives

C-FACE MOTOR MOUNTING

Accommodates readily available C-face motors. Also available for P-base and IEC motors.

CONTINUOUS HIGH PERFORMANCE

Original high efficiency maintained by simple external adjustment resulting in long-term energy savings

DOUBLE ROW THRUST BEARING

Grease lubricated – carries pump thrust load, sealed for outdoor installation

DISCHARGE LOCKED TO PUMP SUPPORT PLATE FOR STRENGTH

ANY MOUNTING REQUIREMENTS

Met by support plate and optional pit cover. Float switches, alternators and other control devices can be easily mounted

STEADY BEARING HOUSING

Precision machined register fit of column, bearing housing and casing assures positive bearing and shaft alignment. Completely interchangeable with all lineshaft bearing options

HEAVY DUTY ONE-PIECE SHAFT

With closely spaced steady bearings assures long life and low maintenance

HEAVY DUTY CASING

Provides rigid support for shaft – closer to impeller load – resulting in longer steady bearing life

REMOVABLE SUCTION COVER

Replaceable wear part for low operational costs.

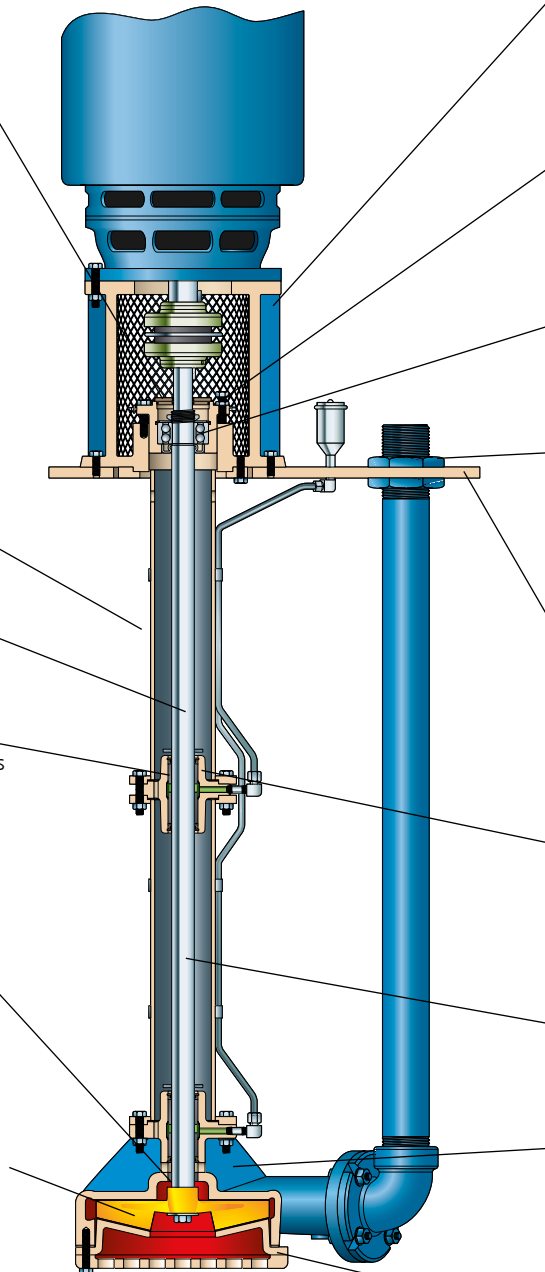

Optional Features for Application Flexibility

Goulds offers a variety of options to meet users' specific plant and application requirements. Your Goulds representative will be glad to recommend the features best suited to your particular service conditions to assure safe, efficient and reliable operation.

Molten Sulfur Pumps

- Jacketed column and discharge pipes (tested to 150 PSIG [1034 kPa])
- Available in all principal alloys
- One-piece, self-lubricating, graphite impregnated steady bearing
- Vapor-proof construction to seal sump vapors
- Balanced, low NPSH, semi-open impeller for optimum performance
- Multiple intermediate bearings permit overall settings to 20 feet (6 m)

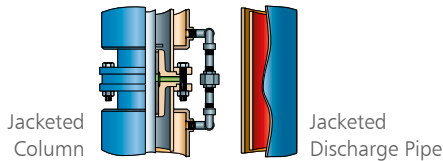

Abrasive Liquids

Goulds sealed bearing arrangement is recommended for applications where abrasive solids are in the pumpage and no clean flush is available. A carbon bearing and lip seal is used for sealing the bearing housing. Spring loaded grease cup is provided.

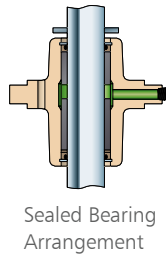

Optional Bearings

Goulds offers the best choice of steady bearings to meet service requirements: optional fluted rubber with rigid shell, bronze, and (standard) carbon.



Mounting Systems

Goulds can provide optional mounting systems to meet specific user requirements including pit covers fabricated with float control mounting points, man holes for access, vapor-proof designs, and lube line holes.



Float Controls

The widest range of float controls is offered to suit the individual requirements of every installation. Ask your Goulds representative for a complete list of options

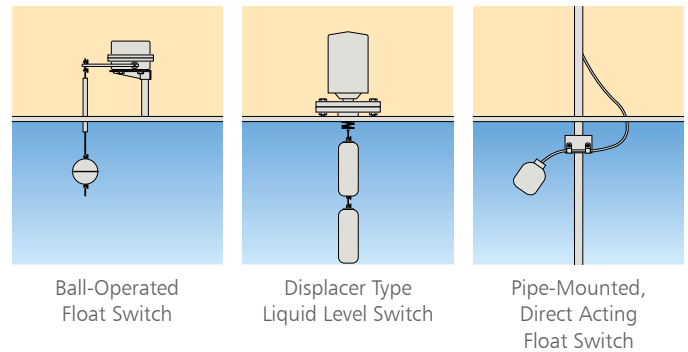

Other Options

- Complete line of controls and starters
- Enclosed lineshaft
- Other types of float controls
- ANSI tank mounting
- Flanged discharge connections

Maximum Sealing Flexibility: Vapor-Proof Construction

Optional upper stuffing box allows use of wide range of sealing arrangements to meet specific user requirements for sealing toxic, hazardous, noxious or corrosive fumes. With this option, the discharge pipe and all fittings are sealed at the support plate. Your Goulds representative will gladly recommend the best sealing solution for your service, some of which are illustrated here.

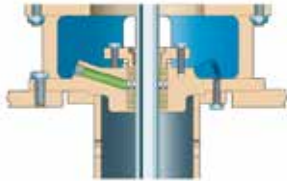

PACKED BOX
Standard vapor-proof sealing option. Includes packing, lantern ring and grease lubricator (not illustrated).

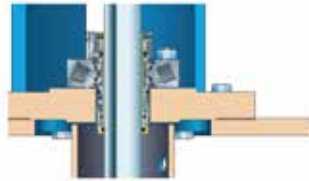

DOUBLE CARTRIDGE SEAL
Available in wet or dry versions to control emissions.

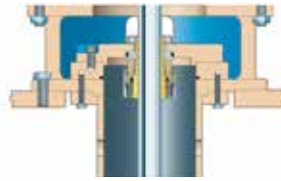

DRY RUNNING SEAL
Dry running, non-contacting cartridge gas seal. Pressurized air barrier between seal faces prevents vapor leakage.

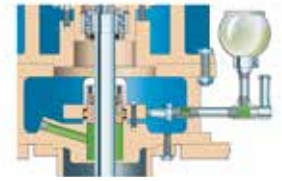

SINGLE OUTSIDE SEAL
Mechanical seal with oil lubricator and sight glass. Outside mount has no metal parts in contact with vapors.

Hydraulic Coverage

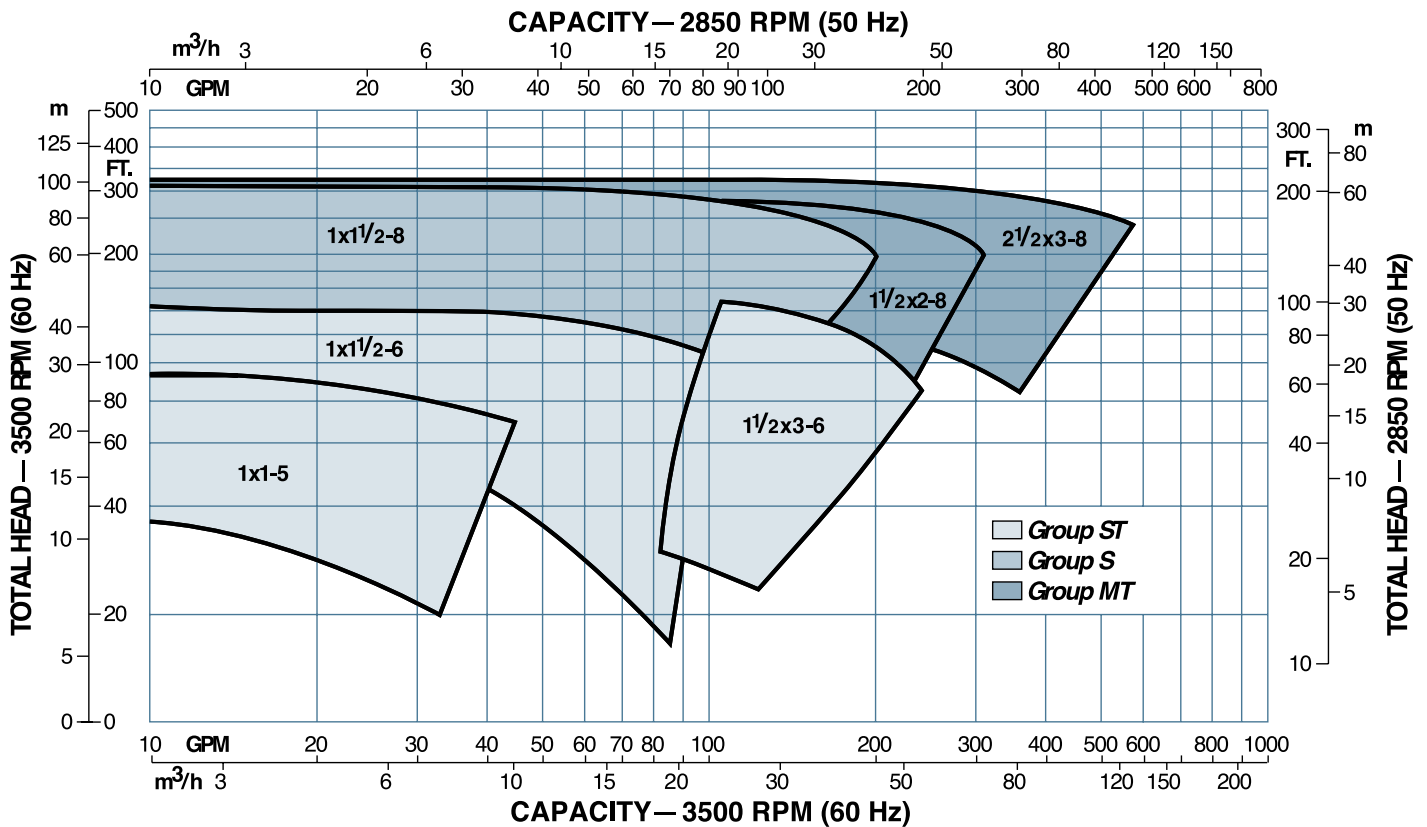

Hydraulic Coverage

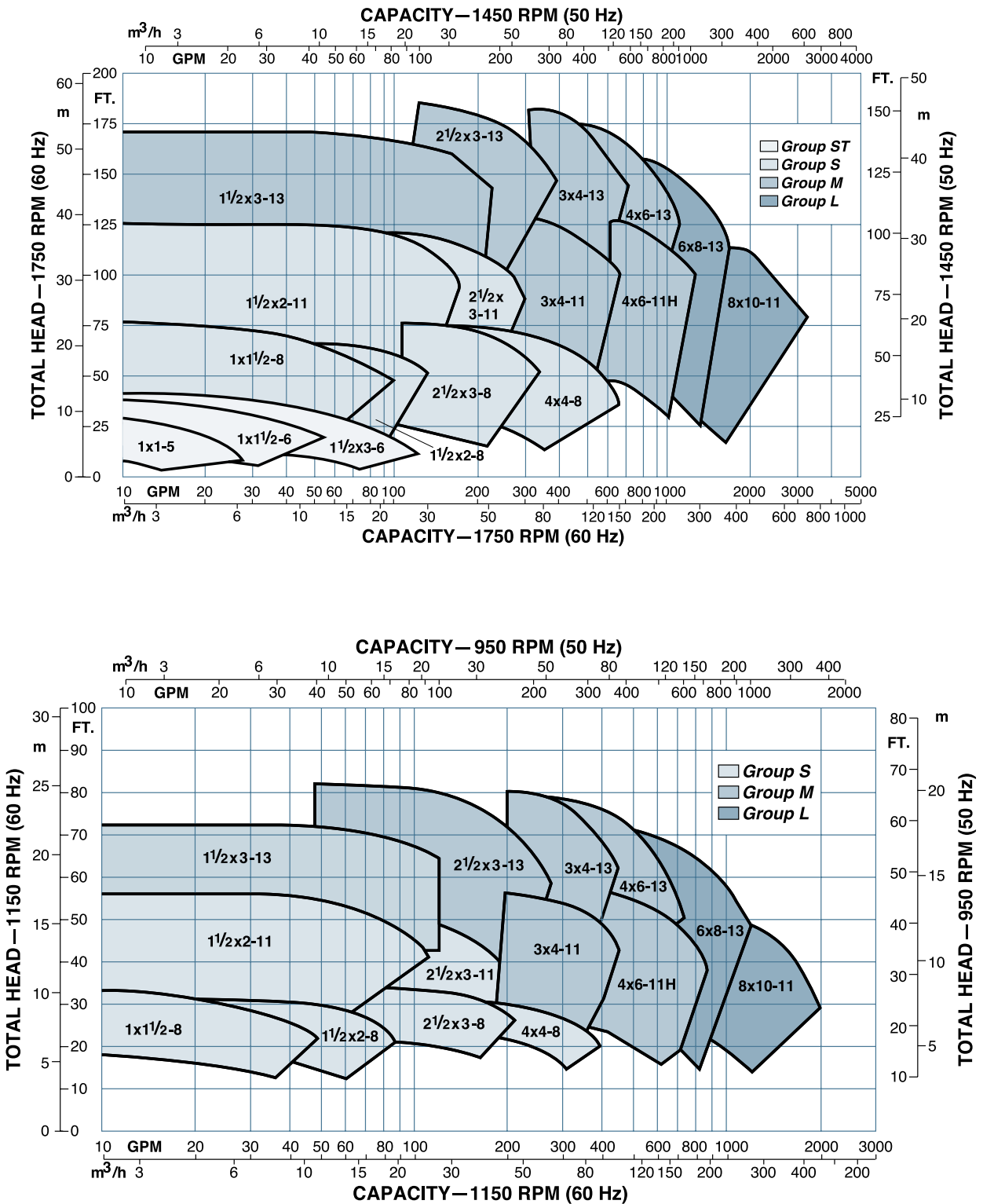

Dimensions

All dimensions in inches and (mm). Not to be used for construction.

	ST			S						S/MT		MT	
	1x1-5	1X1.5-6	1.5X3-6	1X1.5-8	1.5X2-8	2.5X3-8	4X4-8	1.5X2-11	2.5X3-11	1.5X2-11	4X4-8	1.5X2-8	2.5X3-8
A	3.6 (92)	3.6 (92)	3.6 (92)	3.6 (92)	3.6 (92)	3.6 (92)	4 (102)	4 (102)	4 (102)	4 (102)	4 (102)	4 (102)	4.5 (114)
B	1.5 (38)	2 (51)	3 (76)	2 (51)	2 (51)	3 (76)	4 (102)	2 (51)	3 (76)	3 (76)	4 (102)	3 (76)	4 (102)
E	8.1 (205)	8.4 (213)	9.2 (232)	10.1 (256)	9.6 (244)	10.3 (262)	12.1 (306)	11.4 (289)	12.1 (306)	12.37 (314)	12.1 (362)	11.4 (289)	13.6 (346)
G	22 (559)	22 (559)	22 (559)	22 (559)	22 (559)	22 (559)	26.5 (673)	26.5 (673)	26.5 (673)	31 (787)	26.5 (673)	26.5 (673)	31 (787)
R	6 (152)	5.8 (147)	5.3 (135)	4.3 (109)	4.4 (112)	3.8 (97)	3.3 (84)	4.6 (117)	4.2 (107)	4.56 (116)	3.3 (84)	4.4 (112)	3.8 (97)
Q*	14.3 (362)	15.3 (387)	16.8 (425)	17 (432)	17 (432)	18.5 (467)	22.5 (572)	20.5 (521)	22.5 (572)	22 (599)	22.5 (572)	20 (508)	22.8 (578)

	M							L						
	3X4-11	4X6-11H	1.5X3-13	2.5X3-13	3X4-13	4X6-13	LF 1X1.5-8	LF 1X2-10	LF1.5X3-13M	LF1.5X3-13L	6X8-13	6X8-13	8X10-11	8X10-11
A	4.5 (114)	4.5 (114)	4.5 (114)	4.5 (114)	4.5 (114)	4.5 (114)	2.88 (73)	4 (102)	2.75 (70)	2.75 (70)	10.4 (264)	10.4 (264)	10.4 (264)	10.4 (264)
B	4 (102)	4 (102)	3 (76)	3 (76)	4 (102)	4 (102)	2 (51)	2 (51)	2 (51)	2 (51)	6 (152)	8 (203)	8 (203)	10 (254)
E	12.8 (325)	14.3 (362)	13.6 (346)	13.2 (335)	13.8 (351)	14.8 (375)	9.54 (242)	11.5 (292)	14 (356)	14 (356)	21.5 (546)	21.5 (546)	24.3 (616)	24.3 (616)
G	31 (787)	31 (787)	31 (787)	31 (787)	31 (787)	31 (787)	22 (559)	31 (787)	31 (787)	31 (787)	--	--	--	--
R	4 (102)	3.7 (94)	4.8 (122)	4.7 (119)	4.3 (109)	3.7 (94)	6.19 (157)	5.44 (138)	5.44 (138)	5.44 (138)	6.9 (175)	6.9 (175)	5.3 (135)	5.3 (135)
Q*	24 (610)	26.5 (673)	25 (635)	25 (635)	25.5 (648)	27.5 (699)	17 (432)	19.8 (503)	23.8 (605)	23.8 (605)	38.5 (978)	39.5 (1003)	42.5 (1080)	43.5 (1105)

*Add 3 in. (76) for float mounted option.

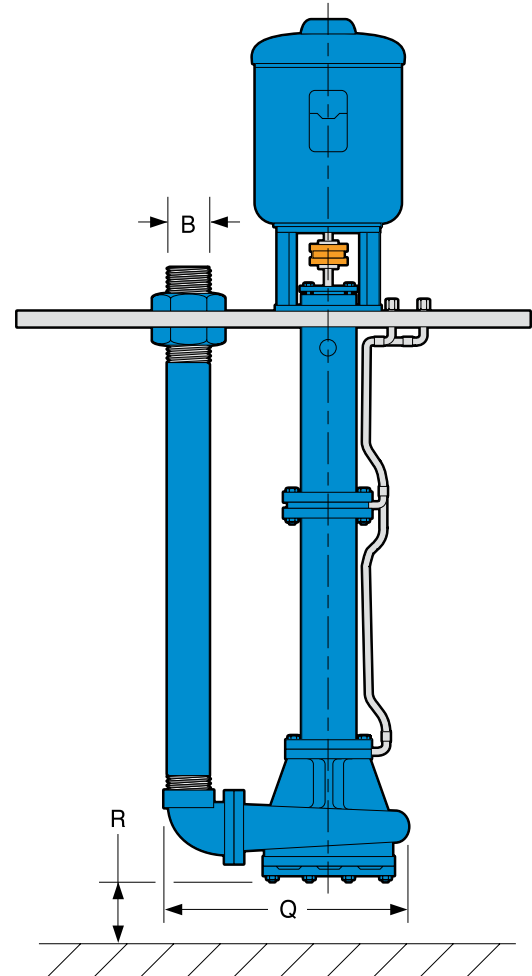
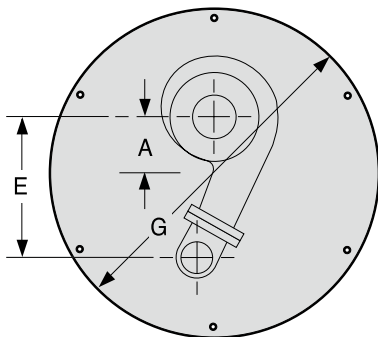
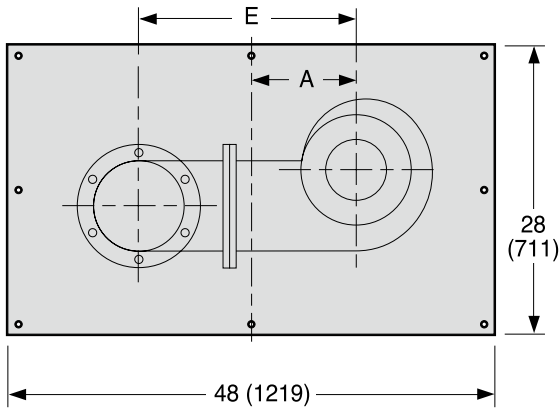

3171 family of pumps



3171



CV 3171



LF 3171



API 3171



NM 3171

Pump Type	Goulds Model	Capacity M ³ /Hr (GPM)	TDH Meters (Feet)	Temperature °C (°F)	Pit Depth Meters (Feet)
VS4	3171	722 (3180)	95 (344)	232 (450)	6 (20)
	API 3171	722 (3180)	160 (525)	232 (450)	6 (20)
	CV 3171	295 (1300)	126 (230)	232 (450)	6 (20)
	LF 3171	50 (220)	290 (950)	232 (450)	6 (20)
	NM 3171	284 (1250)	92 (300)	93 (200)	5 (16)



— An ITT Brand

240 Fall Street
 Seneca Falls, NY 13148
 Phone: 315.568.2811
 Fax: 315.568.2418
www.gouldspumps.com

© 2025 ITT Goulds Pumps Inc.

B.3171.en-US.2025-01