



DV-25

Dia-Flo[®]
Diaphragm Valves
Product Selection Guide



ITT

Table of Contents

	Section
Introduction	1
Markets Served	
Typical Services	
Common Applications	
Diaphragm Valve Products	2
Features and Benefits	
Body Selections	
Diaphragm Selections	
Bonnet Assembly Selections	
Finishes and Coatings	
Diaphragm Valve Actuation.....	3
Pneumatic Actuation	
Types	
Features	
Sizing Charts	
Other Available Actuator Options	
Diaphragm Valve Accessories	4
Accessories for Manual Valves	
Accessories for Actuated Valves	
Diaphragm Valve Technical Data	5
Pressure / Temperature Charts	
Valve and Actuator Weights	
Material Specifications and Industry Standards	
Valve Drawings / Dimensions	
Bill of Materials	
Flow Coefficients and Computations	
Service Guide	
Other Information	6
How to Order	
Maintenance Instructions	
Flange Gasket and Storage Recommendations	
Actuator Diaphragm Identification	
Facts and Recommended Guidelines	
Terms and Conditions	

Internal Page Numbering

Section	Page	Revision	Date
1	1	0	09/15

Section 1

Introduction



Contained in this section:

- Markets Served
- Typical Services
- Common Applications

Introduction

ITT is a leader in valve technology and the foremost innovator of diaphragm type valves. The diaphragm valve is dependable, cost effective and versatile and is installed across the world in virtually every type of process plant.

Our reputation for delivering high quality valve solutions is well earned. Active participation in the nuclear power industry through the sale of diaphragm valves resulted in an ASME Nuclear N Stamp that we have held since 1971. Today, our total quality approach is a critical part of all our business activities.

We differentiate ourselves through Best-In-Class customer service, and provide innovative, high quality valves that solve problems and meet your needs...on time.

ITT is committed to helping industry operate more effectively, efficiently and safely. Aided by our experienced sales team and backed by an international network of distributors, we stand ready to meet the critical needs of our customers on a worldwide basis.



Major Markets Served

Chemical

Dia-Flo® diaphragm valves, available in a wide variety of metals, solid plastics, plastic, rubber and glass linings, are well suited to the handling of multiple chemical applications. Sulfuric and hydrochloric acid, hydrofluoric acid, and sodium hydroxide are typical applications handled by Dia-Flo® diaphragm valves. The broad selection of body materials and diaphragms typically provides a chemically compatible and economical solution for almost any process system not exceeding 200 psi (13.8 bar) or 350° F (177° C). Available in weir and straightway designs, both manual or automated, the Dia-Flo® diaphragm valve is capable of handling clear fluids as well as slurries.



Pharmaceutical

Dia-Flo® Diaphragm Valves are commonly utilized on the chemical side of pharmaceutical manufacturing. Dia-Flo® valves are particularly suitable for this market, as they...



- Can be cleaned in place without disassembly or removal from the pipeline
- Have no pockets or cavities to entrap process or cleaning fluids
- Can be steam sterilized

Similar to ITT's Pure-Flo hygienic diaphragm valves, Dia-Flo® valves are available in FDA compliant body and diaphragm materials.

Mining

Dia-Flo® diaphragm valves, both weir and straightway, are installed in various process lines within gold, copper, zinc and phosphate mines. Common applications include chemical feed, process feed, metal refinery and filter press lines. The Dia-Flo® straightway diaphragm valve, due to the unobstructed flow path and minimal cavities, is well suited for handling abrasive and corrosive slurry applications in line sizes 1" to 12". The chemical feed and process feed areas typically utilize cleaner fluids and utilize Dia-Flo® weir diaphragm valves.



Weir Type Valve in Phosphoric Acid Service

Nuclear Power Plants

The nuclear industry utilizes Dia-Flo® diaphragm valves in a variety of nuclear services including radwaste, chemical volume control, boron regeneration, steam generator blow down, and service water systems. ITT maintains the ASME Section III nuclear power plant components “N” stamp – classes 2 & 3 and complies with ANSI B31.1 power piping codes.



Fossil Power Plants

Demineralizer / Condensate Polisher

Dia-Flo® diaphragm valves have been proven the most reliable design for demineralizer and condensate polishers for more than fifty years. The plastic lined weir body diaphragm valve is the valve of choice because of its clean and versatile design. The diaphragm isolates working parts from the process fluid and there are no packing glands to maintain.

Flue Gas Desulphurization (FGD)

Dia-Flo® diaphragm valves provide a reliable and economical solution for limestone and gypsum slurries for on-off and throttling applications. The diaphragm isolates working parts from the process fluid and is able to close over suspended solids. Dia-Flo® is also an excellent choice in filtrate, reclaim, mist eliminator wash, and gypsum dewatering due to its reliable performance and low cost. Additionally, Dia-Flo® has been used extensively in FGD waste water treatment systems due to the simplicity in design, low maintenance and cost of the diaphragm.

Water Treatment

Dia-Flo® diaphragm valves, due to their versatility in body and diaphragm materials, provide an economical solution for demineralizers, deionizers, reverse osmosis systems and filtration systems. The typical valves utilized in these systems are Dia-Flo® weir diaphragm valves with PP (Polypropylene) or ETFE lining, PTFE or EPDM diaphragms with either manually operated or Dia-Flo® pneumatically operated actuators. Typical accessories include limit switches, adjustable opening stops and handwheel opening devices.



Typical Services

Corrosion

The thousands of combinations of valve body materials and diaphragms offer a practical solution to almost any corrosive fluid. Enhanced materials technology provides us with the ability to handle your corrosive applications at increased temperatures. Additionally, any combination will provide the basic design features of in-line maintenance, bonnet isolation and positive, bubble tight closure.

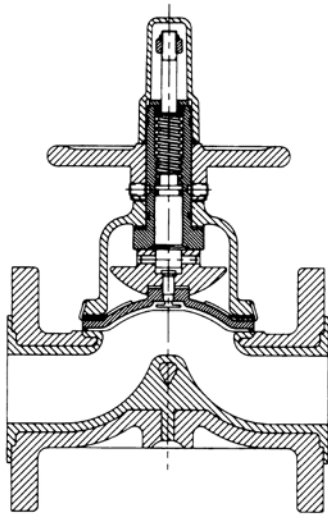

Abrasion

Hundreds of combinations of abrasion resistant diaphragms and body linings are available to solve abrasive problems. The fluid contacts only the abrasion resistant diaphragm and body or lining because the diaphragm isolates the working parts from the process fluids.

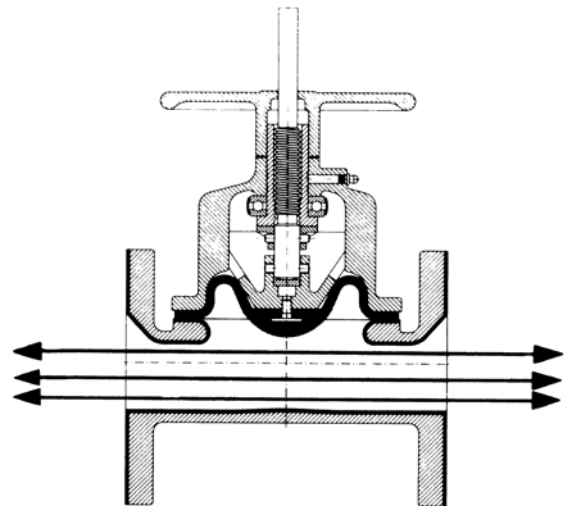

Clogging

Viscous fluids, fibrous slurries and other materials requiring full flow valve characteristics pass directly through the Dia-Flo® straightway diaphragm valve. The diaphragm lifts high into the bonnet offering negligible resistance to flow in either direction, thus eliminating any possibility of clogging. Conversely, positive closure is assured by the large area of contact between the resilient diaphragm and the body. Diaphragm valves are self-draining and self-cleaning.



Vacuum and Gas Handling

Stem leakage is improbable because the diaphragm completely seals the bonnet from the gas traveling through the valve body. Furthermore, absolute closure of the valve greatly reduces the possibility of gas leakage when in the closed position. These features, combined with low gas permeability, make the Dia-Flo® weir diaphragm valve especially suitable for gas and / or vacuum services.

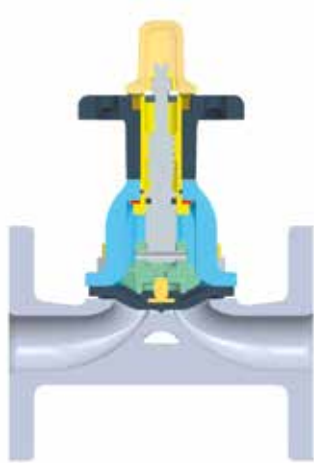

Contamination

The inherent features of the diaphragm valve make it an ideal candidate for applications where contamination potential must be eliminated. The valve diaphragm isolates the working parts of the bonnet assembly from the process fluids. These valves can be cleaned in place without removal from the pipeline and have no cavities or pockets to trap process or cleaning fluids.



Control

Precision throttling of highly corrosive or abrasive media is provided by the Dualrange® diaphragm valve. A double compressor assembly acts as a valve within a valve. At low flow rates, the contoured center of the diaphragm is operated by the inner compressor for accurate control. When the inner compressor is fully opened, both compressors move as a single unit to deliver full flow capacity.

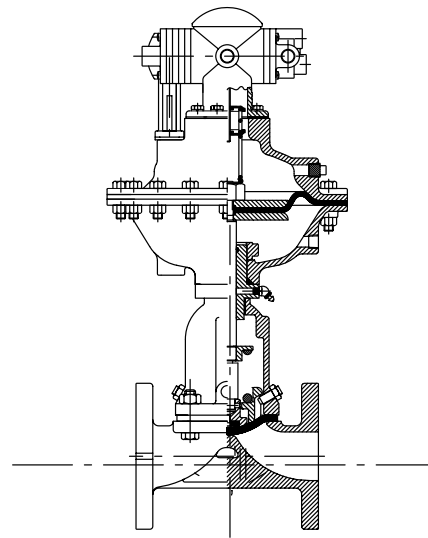

Applications

Weir

- Acids
- Caustics
- High Purity Chemicals
- Agricultural Chemicals
- Demineralizer Systems
- Plastics Manufacturing
- Flue Gas Desulfurization



Solid Plastic Weir Type Valve on Acid Service

Straightway

- Abrasive Slurries
- Flue Gas Desulfurization (FGD)
- Titanium Dioxide (TiO₂)
- Fertilizers
- Phosphate
- High-Capacity Applications
- High Solid Content Abrasives



Straightway Valve on Abrasive Slurry Service

For specific application information, contact your ITT Technical Sales Representative.

Section 2

Diaphragm Valve Products



Contained in this section:

Weir Valves

- Features and Benefits
- Body Selections
- Diaphragm Selections
- Bonnet Assembly Select

Straightway Valves

- Features and Benefits
- Body Selections
- Diaphragm Selections
- Bonnet Assembly Selections

Features and Benefits

Weir Type Valve

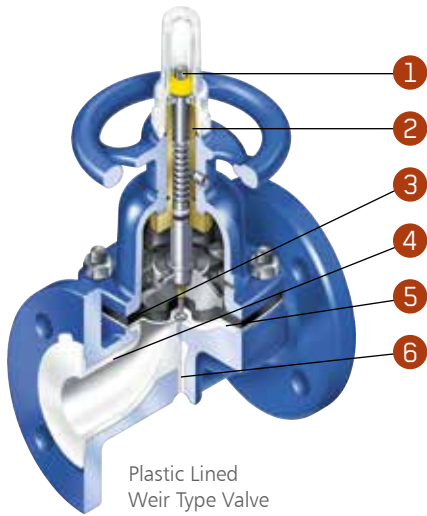

Straightway Valve

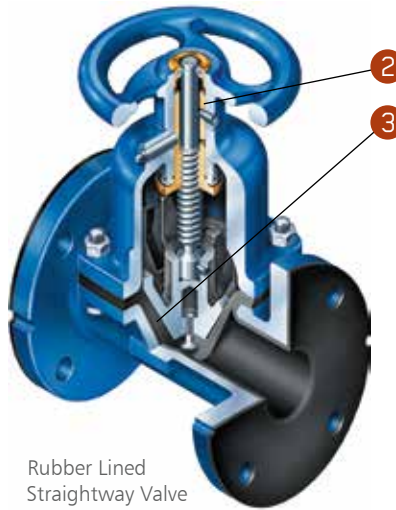

Modes of Operation

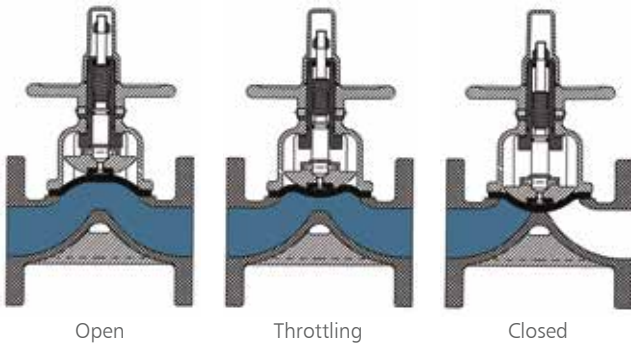

Modes of Operation

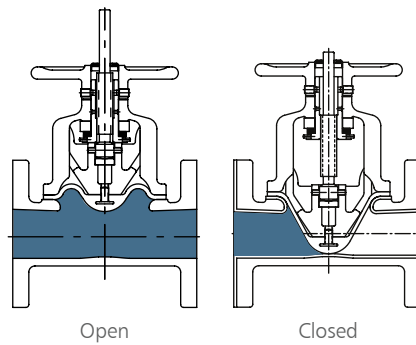

Versatile and Economical

Broad range of body materials and diaphragm materials.

- Metals
- Plastic Linings
- Rubber Linings
- Glass Linings
- Solid Plastic
- Choose from 12 grades of Elastomers or PTFE Diaphragms

Features and Benefits

1 Adjustable Travel Stop

- Prevents overclosure of the valve and prolongs diaphragm life. The adjustability feature assures that leak-tight shutoff can be maintained throughout the valve's life.

2 Bronze Bushing

- Reduces turning torque and enhances cycle life in "dirty" atmospheres.

Sealed Bonnet

- Offers secondary process containment to control fugitive emissions.
- Supplied with leak detection port as standard.

Floating Tube Nut*

- Prevents point loading of the stud on PTFE diaphragms, which enhances diaphragm life, particularly in high temperature and high cycle applications.
- 100% Seat & Shell Testing
- All valves are pressure tested bubble tight prior to shipment. No visible leakage is allowed.
- Extensive selection of body and diaphragm materials and actuation packages.
- Allows optimum selection of materials for service conditions, often without expensive upgrades.

3 Bonnet Isolation

- The diaphragm isolates the working parts of the valve from process fluids.

4 Streamlined Fluid Passage

- The smooth contoured body has minimal pockets, cavities or dead spaces, which prevent accumulation or stagnation of process fluids or contaminants.

No Packing Gland or Packing

- No more packing gland adjustment required or stem packing leakage problems for improved control of fugitive emissions.

Positive Leak Tight Closure

- Bubble tight closure is provided in accordance with MSS SP-88.

In-Line Maintenance

- Easily maintained when required for reduced downtime and lower cost of ownership.

5 Molded Closed 2-Piece PTFE Diaphragm*

- Diaphragms are molded to the exact contour of the weir for superior shutoff capabilities.
- 2-piece configuration eliminates delamination of PTFE which is common to 1-piece configurations.
- Superior flex life
- Reduced permeation
- Excellent chemical resistance

6 Line-Lok*

- Unique feature in all plastic lined weir valves that prevents liner flexing over the weir, which reduces the potential for liner cracking.

* Weir type valve only

Weir Valve Selections

Unlined Metal

- Excellent Cvs
- Complete Selection of End Connections
- ASTM Materials Include:
 - Cast Iron ASTM A-126 Class B
 - Ductile Iron ASTM A-395 Grade 60-40-18
 - Cast Steel ASTM A-216 Grade WCB
 - 316 Stainless Steel ASTM A-351 Grade CF8M
 - 316L Stainless Steel ASTM A-351 Grade CF3M

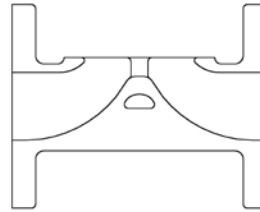

- Bronze ASTM B62 Alloy 836
- Alloy 20 ASTM A-351 Grade CN7M
- Hastelloy C ASTM A-494 Grade CW-6M
- Monel ASTM A-494 Grade M-35-1
- And More

Sec 2: Products



SCREWED METAL²

1/2"-3"	Cast Iron	2401
1/2"-3"	Bronze	2402
1/2"-2"	Stainless Steel (316)	2403
1/2"-2"	Cast Steel	2405
1/2"-2"	CN7M	2407
1/2"-2"	Monel	2408
1/2"-2"	Hastelloy	2410
1"-3"	Ductile Iron	2412



FLAT-FACED FLANGED METAL^{1,2}

1/2"-12"	Cast Iron	2431
1/2"-6"	Bronze	2432
1/2"-12"	Ductile Iron	2441

RAISED FACE FLANGED METAL^{1,2}

1/2"-8"	Stainless Steel	2433R
1/2"-8"	Cast Steel	2435R
1/2"-8"	CN7M	2437R
1/2"-8"	Monel	2438R
1/2"-8"	Hastelloy	2440R



SOCKET WELD METAL²

1/2"-3"	Stainless Steel (316L)	2470
1/2"-3"	Cast Steel	2472
1/2"-3"	CN7M	2474

SOCKET (SOLDER)

1/2"-2"	Bronze	2456
---------	--------	------



BUTTWELD METAL²

1/2"-6"	Stainless Steel (316L)	
	Schedule 5	2464
	Schedule 10	2465
	Schedule 40	2466

Maximum temperature for all of the above configurations is 350° F (177° C).

Notes:

1. 3/4" flanged valve is supplied with 1" bonnet and diaphragm.
2. 1 1/4" valves are supplied with 1 1/2" bonnet and diaphragm.
3. Temperature may decrease dependent upon media, pressure and valve size.

Weir Valve Selections

Rubber Lined Bodies

- 1/8" Minimum Lining Thickness Ductile Iron or Cast Iron
- Available Full Flat Faced Flange Lining
- Ductile Iron or Cast Iron Available

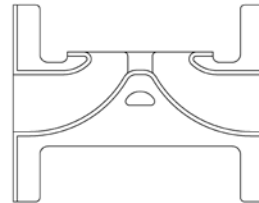

Broad Choice of Lining Materials



Neoprene

A synthetic base elastomer with some physical properties similar to natural rubber. Superior to natural rubber in resistance to heat, ozone, sunlight and oil. Typical applications include phosphoric acids; magnesium oxide and sodium hydroxide. Maximum temperature 200° F (93° C)³



Soft Rubber

Good resistance to most inorganic chemicals with the exception of strong oxidizing agents. Exhibits outstanding abrasion resistance. Typical applications include gypsum, flyash, titanium dioxide slurries and sewage. Maximum temperature 180° F (82° C)³



Hard Rubber

Better chemical and heat resistance than soft rubber. Wide application in organic and inorganic acids and chlorine gas. Typical applications include potable water; oxidizing agents; plating solutions; salts; sludge and ferric chloride. Maximum temperature 200° F (93° C)³



Chlorobutyl

Good heat resistance. Unaffected by cold weather or rapid temperature changes. Typical applications include hydrofluoric acid, various zinc solutions and fertilizer solutions. Maximum temperature 200° F (93° C)³



FLANGED RUBBER LINED^{1,2}

CAST IRON

1/2"-12"	Neoprene	#7	2501
1/2"-12"	Soft Rubber	#5	2516
1/2"-12"	Hard Rubber	#10	2521
1/2"-12"	Chlorobutyl	#16	2522

DUCTILE IRON

1/2"-8"	Neoprene	#7	2550
1/2"-8"	Soft Rubber	#5	2551
1/2"-8"	Hard Rubber	#10	2552

CAST STEEL

1/2"-8"	Neoprene	#7	2561
1/2"-8"	Hard Rubber	#10	2563

Notes:

1. 3/4" flanged valve is supplied with 1" bonnet and diaphragm.
2. 1 1/4" valves are supplied with 1 1/2" bonnet and diaphragm.
3. Temperature may decrease dependent upon media, pressure and valve size.

Weir Valve Selections

Plastic Lined

- $\frac{3}{16}$ " Minimum Lining Thickness*
- Superior Flow Capabilities
- Line-Lok feature
- Wide Selection of Lining Materials

*Lining thickness of PFA is .14" minimum.

Line-Lok is a unique feature of Dia-Flo® diaphragm valves. The weir area is locked firmly to the body eliminating flexing of lining during valve cycling, which can lead to premature liner failure.



Dia-Flo® weir diaphragm valve with Advantage Actuator and SP2.0 switch pack.

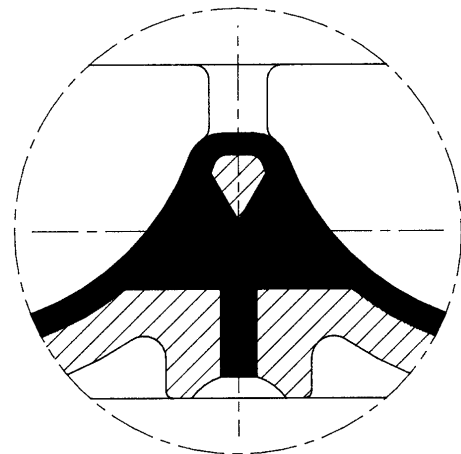
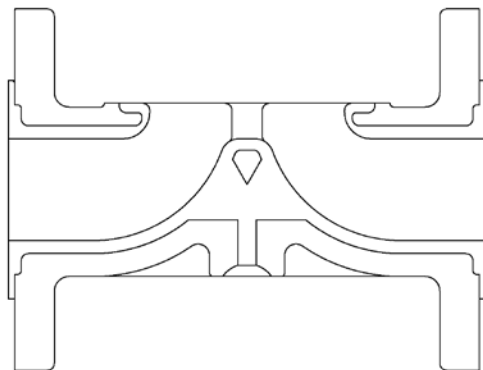

Weir Valve Selections

Plastic Lined



PFA

Excellent chemical resistance to all common solvents, superior high purity resistance, excellent temperature resistance. Maximum temperature 350° F (177° C)³



ETFE

Suitable for strong acids and solvents. Compatible with a very broad range of chemicals under a wide range of conditions. Maximum temperature 300° F (149° C)³



Polypropylene

Especially suitable for organic solvents degreasing agents, excellent resistance to alkalines. Economically priced, poor resistance to chlorinated solvents. Maximum temperature 200°F (93° C)³



PVDF

Very good corrosion and chemical resistance, performs well in many applications at elevated temperatures. Maximum temperature 285° F (140° C)³



PVC

Very good corrosion and weather resistance. Note that temperatures may be restricted. Maximum temperature 140° F (60° C)³

FLANGED PLASTIC LINED^{1,2}

CAST IRON

¾"-8"	ETFE	2529
¾"-8"	PVC	2536
¾"-8"	Polypropylene	2538
¾"-8"	Polypropylene (unpigmented)	2539
¾"-8"	PVDF	2575

DUCTILE IRON

¾"-8"	PVDF	2555
¾"-8"	Polypropylene	2558
¾"-8"	ETFE	2559
1"-6"	PFA	2566

CAST STEEL

¾"-8"	ETFE	2545
¾"-8"	Polypropylene	2546
¾"-8"	PVDF	2548
½"-6"	PFA	2564

STAINLESS STEEL

½"-6"	PFA	2540
¾"-8"	ETFE	2549

Notes:

1. ¾" flanged valve is supplied with 1" bonnet and diaphragm.
2. 1¼" valves are supplied with 1½" bonnet and diaphragm.
3. Temperature may decrease dependent upon media, pressure and valve size.

Weir Valve Selections

Solid Plastic

- Lightweight and economical
- Excellent interior / exterior corrosion resistance
- Body materials include:
 - PVC (Polyvinyl chloride)
 - CPVC (Chlorinated polyvinyl chloride)
 - PVDF (Polyvinylidene fluoride)
 - Polypropylene
- End Connections include:



Solid plastic PVDF body with ring flanges and PAS plastic manual bonnet.

Sec 2: Products

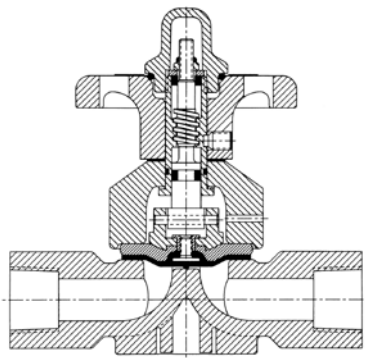

NPT THREADED

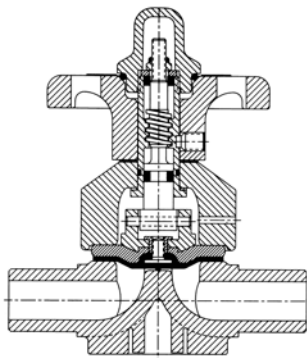

SPIGOT WELD

PVC & CPVC: IPS SCH 80
PP & PVDF: DIN 11

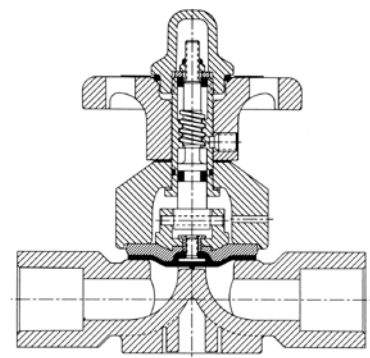

SOCKET WELD

PVC & CPVC: SCH. 80
PP & PVDF: SCH. 80

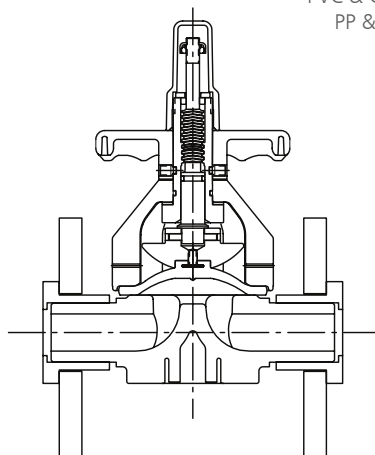

FLANGED*

PP & PVDF: RING FLANGE

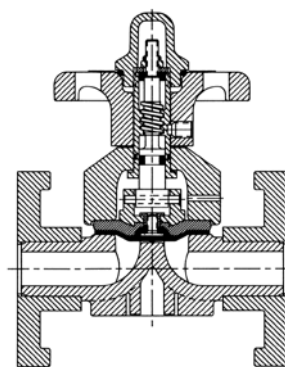

FLANGED*

PVC & CPVC: FIXED FLANGES

Weir Valve Selections

Solid Plastic

The body of the Dia-Flo plastic diaphragm valve is available in a variety of high-performance engineered polymers including polyvinyl chloride (PVC), chlorinated polyvinyl chloride (CPVC), and natural polyvinylidene fluoride (PVDF). The bonnet is manufactured from glass-reinforced polymer, PAS (polyarylsulfone). An optional PAS pneumatic actuator is also available.



SCREWED PLASTIC⁴

1/2"-2"	PVC	2406
1/2"-2"	CPVC	2416
1/2"-2"	PVDF ^{2,3}	2417



SOCKET WELD PLASTIC⁴

1/2"-2"	PVDF ^{2,3}	2427
1/2"-2"	PVC	2451
1/2"-2"	CPVC	2463



FLANGED PLASTIC^{2,4}

1/2"-4"	PVC	2436
1/2"-2"	CPVC	2442
1/2"-4"	PVDF ³	2447



SPIGOT WELD PLASTIC⁴

IPS-SPIGOT		
1/2"-2"	CPVC	2443
1/2"-4"	PVC	2486

DLN-SPIGOT⁴

1/2"-4"	PVDF ³	2487
---------	-------------------	------



*150# ANSI Dimensions

Glass Lined

- Excellent lining for contaminant-free or corrosion-resistant applications
- Available in cast or ductile iron
- 100% spark testing before and after assembly assures the highest lining integrity

Flanged Glass Lined^{1,4}

Cast Iron

1/2"-8" Glass 2511

Ductile Iron

1/2"-10" Glass 2544

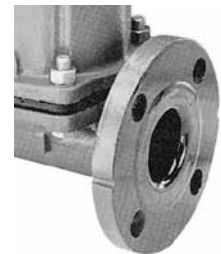

Maximum temperature for glass lined valves is 350° F⁵ (177° C).

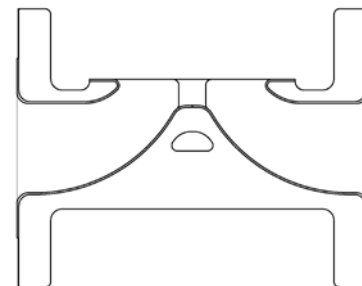

Notes:

1. 3/4" flanged valve is supplied with 1" bonnet and diaphragm
2. Not available in 1 1/4" size
3. Unpigmented
4. 1 1/4" valves are supplied with 1 1/2" bonnet and diaphragm
5. Temperature may decrease dependent upon media, pressure and valve size

Weir Valve Selections

The diaphragm material and design are integral to the successful performance of the diaphragm valve.

10 weir elastomer diaphragms and 2 weir PTFE diaphragms are available to handle a multitude of process fluids and parameters.

Elastomer Diaphragms¹



Grade	Material (FDA Compliant)	Size	Temperature ^{2,3}	Typical Services
Grade B	Black Butyl (FDA Compliant)	1/2"-12"	-20 to 250° F (-29 to 121° C)	Chemicals, gases, stronger acids
Grade W1	White Butyl (FDA Compliant)	1/2"-6"	0 to 225° F (-18 to 107° C)	Foods, beverages, pharmaceuticals
Grade E1	EPDM (FDA Compliant)	1/2"-8"	-30 to 300° F (-34 to 149° C)	Beverages, pharmaceuticals
Grade M	EPDM	1/2"-12"	-30 to 300° F (-34 to 149° C)	Chemicals, acids, hi-temp, abrasives
Grade S	Natural Rubber	1/2"-8"	-30 to 180° F (-34 to 82° C)	Water, abrasives
Grade T	Neoprene ⁴	1/2"-12"	-20 to 200° F (-29 to 93° C)	Weak chemicals, air, oil resistant
Grade DP	Buna N [®] NBR (FDA Compliant) Direct Loaded Valve only	1/2"-3"	10 to 180° F (-12 to 82° C)	For direct load valve only
Grade P	Buna N [®] NBR (FDA Compliant)	1/2"-12"	+10 to 180° F (-12 to 82° C)	Foods, oils
Grade V	Viton [®] FKM ⁴	1/2"-6"	-20 to 325° F (-29 to 163° C)	Specific solvents & chemicals, oils

¹ To be used as general guide; for complete service guide see section 5 of this binder.

² Diaphragms at maximum temperature cannot be used satisfactorily at maximum pressures. Pressure/temperature charts are provided in section 5 of this binder.

³ Cast Iron, Ductile Iron & Carbon Steel should not be used below -20 degrees F (-29 C).

⁴ Viton is a registered trademark of DuPont de Nemours and Co. Inc.

Our elastomer diaphragms are available in a variety of materials to address various process characteristics. Some elastomer diaphragms are softer and better suited to abrasive and slurry applications. Others are harder, providing greater chemical resistivity and higher temperature limitations. All elastomer diaphragms in sizes 1"-8" are molded in the closed position to provide the most effective seal. Each diaphragm contains markings identifying the size, material, mold date and diaphragm supplier.

The molded closed design increases the sealing properties of the diaphragm. The relaxed position of the diaphragm is contoured to the same shape as the weir which increases the ability of the diaphragm to provide a bubble-tight shut-off.

Due to diaphragm area limitations, sizes smaller than 1" are molded open.

Diaphragm Traceability

All diaphragm materials and physical properties are batch traceable via permanent codes molded into the diaphragm tabs. The molding date, material type, and diaphragm size provide traceability to original batch records.

Diaphragm Identification

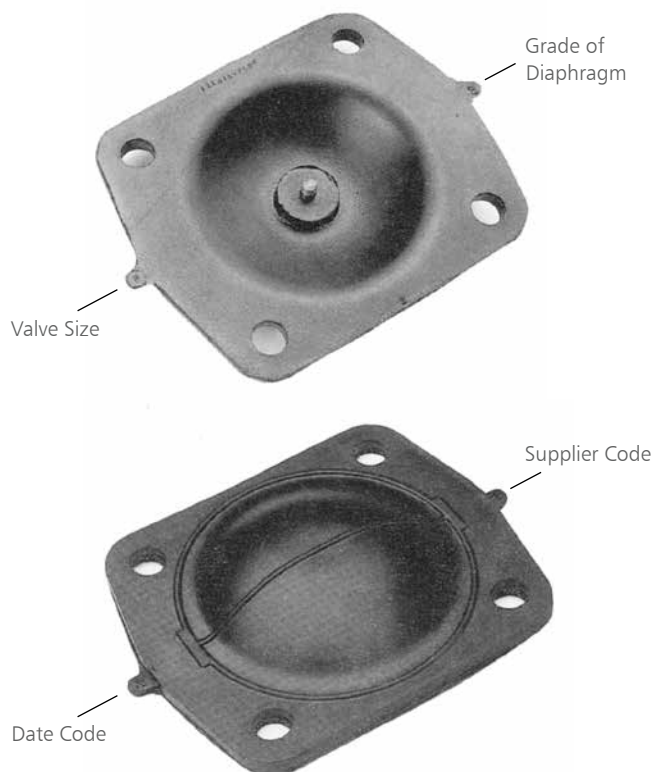

See chart above for Diaphragm Grades.

Weir Valve Selections

PTFE Diaphragms



Grade	Material (FDA Compliant)	Size	Temperature ^{2,3}
Grade TM	Modified PTFE (FDA Compliant)	1/2"-6"	-30 to 350° F (-34-177° C)
Grade R2	PTFE (FDA Compliant)	8"-10"	-30 to 350° F (-34-177° C)

The two-piece PTFE (Polytetrafluoroethylene) diaphragm assembly utilized in the Dia-Flo® diaphragm valve has proven through years of outstanding service to be the best design available. The two-piece construction, consisting of PTFE diaphragm and ethylene propylene elastomer backing cushion, fully eliminates the problem of delamination permeational cracking common to competitive "PTFE-faced" designs.

To ensure the best possible diaphragm, ITT maintains a continuing development program to utilize new materials and improve existing compounds. The result of this effort is the recent introduction of the PTFE-grade TM diaphragm (1/2"-6").

Proven benefits of the PTFE grade TM diaphragm versus conventional PTFE diaphragms are:

- Reduced permeation due to a more homogeneous microstructure with minimal voids
- Reduced cold flow similar to 25% carbon reinforced PTFE
- Increased cycle life due to a more amorphous compound



PTFE Diaphragm Assembly

Floating Tube Nut

The floating tube nut feature contributes largely to the successful operation of plastic diaphragms in Dia-Flo® diaphragm valves. The downward force of the stem is transferred to the compressor, bypassing the tube nut. The result is that forces are evenly distributed over the seating area of the diaphragm, thus reducing cold flow and stud pull out concerns. This design is also used on 6" and larger elastomer diaphragms.

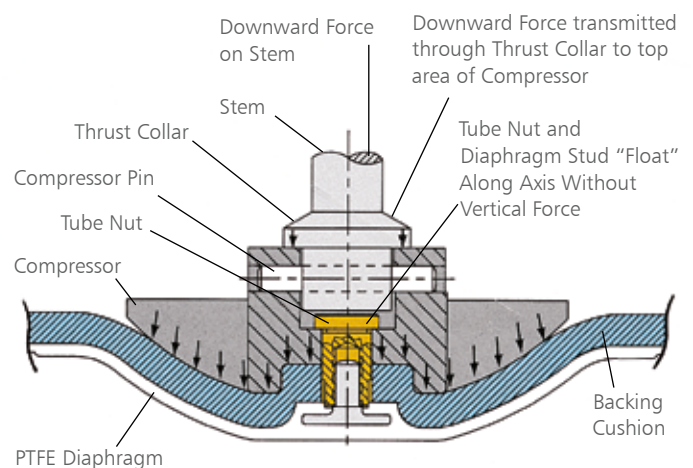
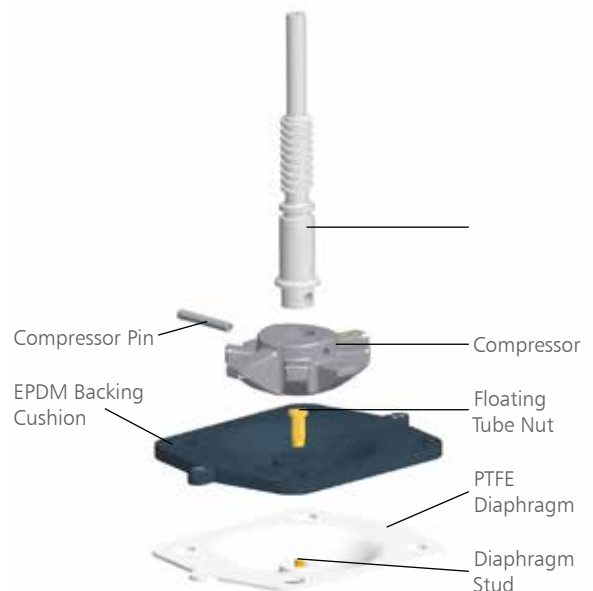

Weir Valve Selections

Manual Bonnet Assemblies

Dia-Flo® diaphragm valve bonnet assemblies are equipped as standard with:

- Bronze Stem Bushing
- Molded-In Fingers*
- Grease Fitting** (6"-12")
- Thrust Bearing Visual Position Indication
- Adjustable Travel Stop (1/2"-4")
- Permanently Sealed Lubrication (1/2"-4")
- Clear Stem Cover (1/2"-4")

*In conjunction with the compressor, the fingers positively support the diaphragm from the closed to open position. The diaphragm is lifted high when the valve is opened and is pressed tightly against the weir when the valve is closed. It is supported in all positions by alternate fingers of the compressor and bonnet. Fingerplates in place of molded in fingers are utilized in 3" through 6" stainless steel bonnet assemblies.

For specific 902 and 903 bonnet parts call-out refer to the technical section of this binder.

Refer to Bonnet Assembly Options pages for other bonnet variations.



PVDF corrosion resistant coated bonnet shows the molded-in fingers utilized to support the diaphragm in the open position.

** Not used with sealed bonnet

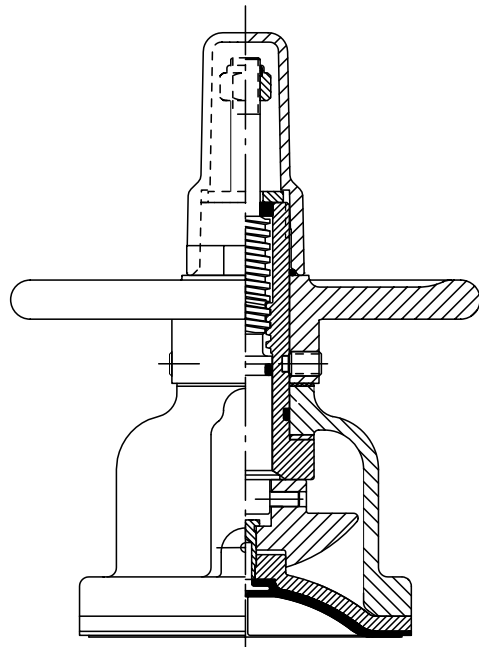

903 BONNET ASSEMBLY

Standard on valves 1/2"-4"

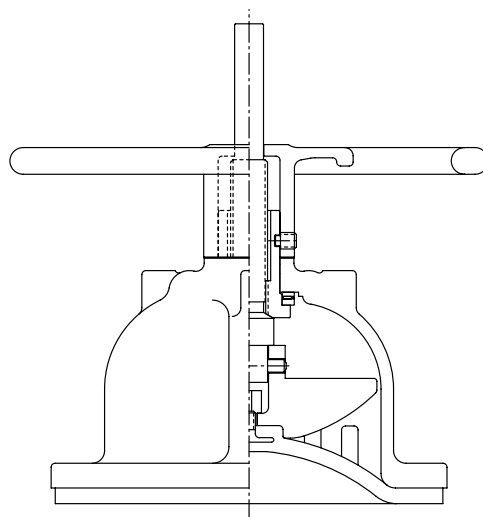

902 BONNET ASSEMBLY

Standard on valves 6"-12".

See technical section for parts call-outs and materials for 902 and 903 assemblies.

Straightway Valves

Features and Benefits

Ideal for slurry, abrasive and corrosive applications, the Dia-Flo® Straightway Diaphragm Valve provides the following benefits:

Slurry Applications

Due to the streamlined fluid passage, the Dia-Flo® Straightway Valve can handle slurries, without solid particles becoming entrapped in cavities or crevices which may obstruct the operation of other valve types. In addition, the unobstructed flow path allows the valve to be rodded through.

Abrasion Resistant

Available in four rubber linings: Soft Rubber, Hard Rubber, Neoprene®, and Butyl the Straightway Valve is well suited to handling corrosive and abrasive services.

Corrosion Resistant

In addition to the rubber linings, ETFE and polypropylene linings are available to handle the most corrosive services. To protect the valve exterior, PVDF and white epoxy coatings are available.

Conventional Straightway Design

The Dia-Flo® Straightway Valve is a conventional design as opposed to a reduced port straightway design. A reduced port straightway design is similar to a pre-pinch valve, in that the flow path cross-sectional area is generally reduced. The reduction in area results in reduced flow capacity (Cv), increased velocity, increased pressure drop and accelerated wear through the valve.

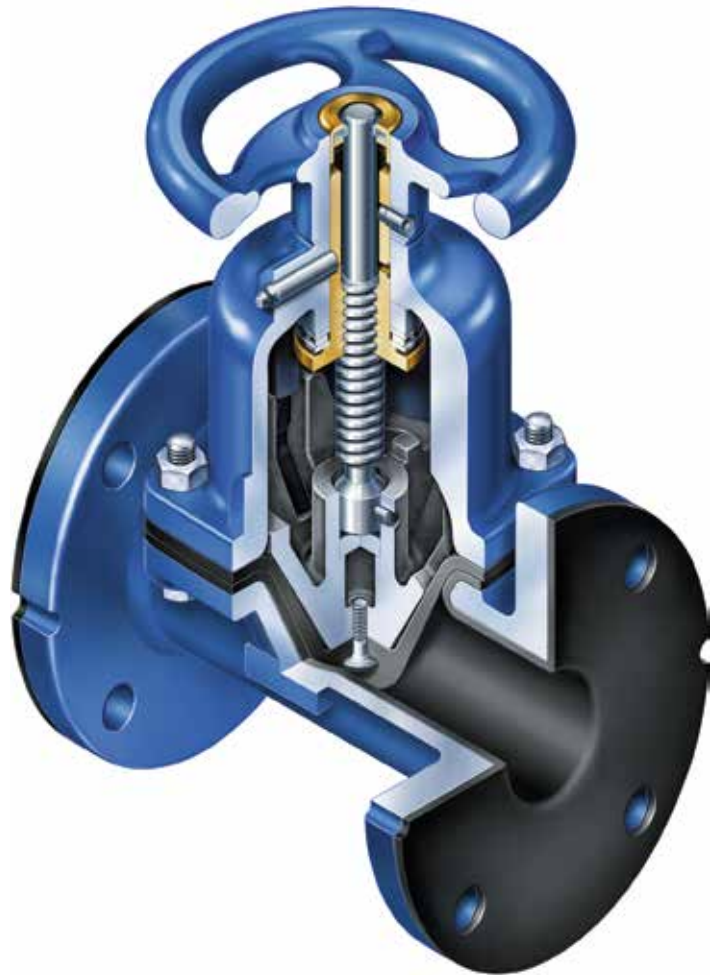

Straightway Valves

Additional Features

- Can be rodded out in either direction
- Unimpeded Flow
- Negligible pressure drop
- Self-draining when piping is pitched

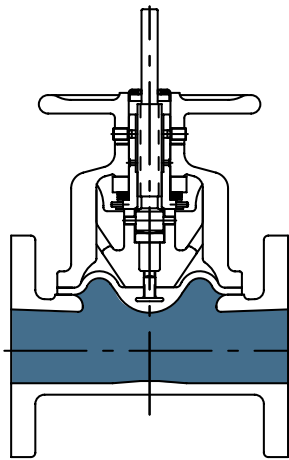

Valve Open

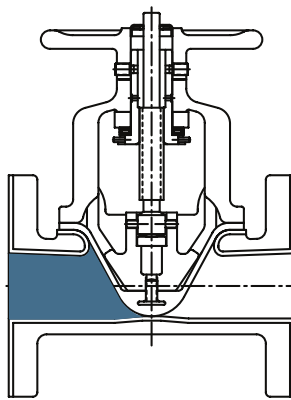

Valve Closed



Valve Open



Straightway Rubber Lined Valves in Phosphoric Acid Service

Straightway Valves

Unlined Metal

- Excellent CVs
- Flanged or raised face flanges
- ASTM materials include:
 - Cast Iron ASTM A-126 Class B
 - Ductile Iron ASTM A-395 Grade 60-40-18
 - Stainless Steel ASTM A-351 Grade CF8M
 - Cast Steel ASTM A-216 Grade WCB

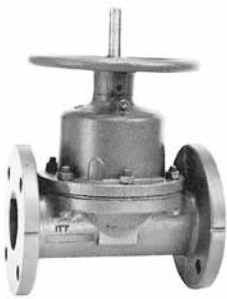

FLANGED METAL

1"-12"	Cast Iron	2811
1"-12"	Ductile Iron	2812

RAISED FACE FLANGED METAL

1"-8"	Stainless Steel	2813R
1"-8"	Cast Steel	2815R

Maximum temperature for all of the above configurations is 225° F (107° C).

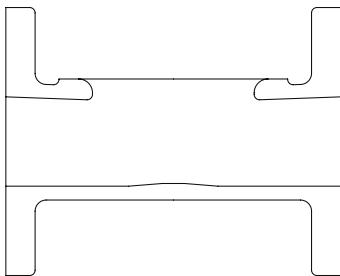

Plastic Lined

- Superior Flow Characteristics
- $\frac{3}{16}$ " Minimum Lining Thickness
- Excellent Corrosion Resistance



ETFE

Suitable for strong acids and solvents. Compatible with a very broad range of chemicals under a wide range of conditions. Maximum temperature 225° F (107° C)¹

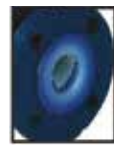

Polypropylene

Especially suitable for organic solvents degreasing agents, excellent resistance to alkalines. Economically priced, poor resistance to Chlorinated solvents. Maximum temperature 200° F (93° C)¹



FLANGED PLASTIC LINED

1"-8"	ETFE (CI)	2829
1"-8"	Polypropylene (CI)	2838
1"-8"	ETFE (DI)	2859

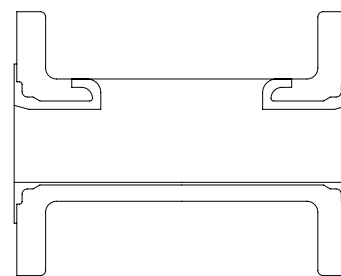

¹Temperature may decrease dependent upon media, pressure and valve size.

Straightway Valves

Rubber Lined

- 1/8" Minimum Lining Thickness
- Cast Iron or Ductile Iron available
- Excellent for slurries and abrasive applications

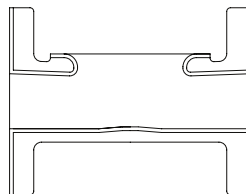

Neoprene

A synthetic base elastomer with some physical properties similar to natural rubber. Superior to natural rubber in resistance to heat, ozone, sunlight and oil. Typical applications include phosphoric acids; magnesium oxide and sodium hydroxide. Maximum temperature 200° F (93° C)¹



Soft Rubber

Good resistance to most inorganic chemicals with the exception of strong oxidizing agents. Exhibits outstanding abrasion resistance. Typical applications include gypsum, flyash, titanium dioxide slurries and sewage. Maximum temperature 180° F (82° C)¹



Hard Rubber

Better chemical and heat resistance than soft rubber. Wide application in organic and inorganic acids and chlorine gas. Typical applications include potable water; oxidizing agents; plating solutions; salts; sludge and ferric chloride. Maximum temperature 200° F (93° C)¹



Chlorobutyl

Good heat resistance. Unaffected by cold weather or rapid temperature changes. Typical applications include hydrofluoric acid, various zinc solutions and fertilizer solutions. Maximum temperature 200° F (93° C)¹



FLANGED RUBBER LINED

CAST IRON

1"-12"	Neoprene #7	2831
1"-12"	Soft Rubber #5	2833
1"-12"	Hard Rubber #10	2834
1"-12"	Chlorobutyl #16	2836

DUCTILE IRON

1"-12"	Neoprene #7	2840
1"-12"	Soft Rubber #5	2841
1"-12"	Hard Rubber #10	2842

¹Temperature may decrease dependent upon media, pressure and valve size.

Straightway Valves

Straightway Diaphragms



Grade	Material	Size	Temperature ¹	Typical Services
Grade SB	Black Butyl (FDA Compliant)	1-4"	0 to 200° F (-18 to 93° C)	Chemicals, stronger acids
Grade SE	EPDM (FDA Compliant)	1-12"	-20 to 225° F (-29 to 107° C)	Chemicals, acids, hi-temp, abrasives
Grade SP*	Buna N® NBR (FDA Compliant)	1-6"	10 to 180° F (-12 to 82° C)	Foods, oils
Grade SS	Natural Rubber	1-12"	-20 to 180° F (-29 to 82° C)	Water, abrasives
Grade ST	Neoprene®	1-12"	-10 to 180° F (-23 to 82° C)	Weak chemicals, air, oil

*2.5" not available

¹ Diaphragms at maximum temperature cannot be used satisfactorily at maximum pressures.

² Cast Iron, Ductile iron & Carbon Steel should not be used below -20 degrees F (-29 C)

Bonnet Assemblies for Straightway Manual Valves

Straightway bonnet assemblies include:

- Indicating Stem
- Bronze Bushing
- Lubrication Fitting
- Cast Iron Bonnet Shell Handwheel

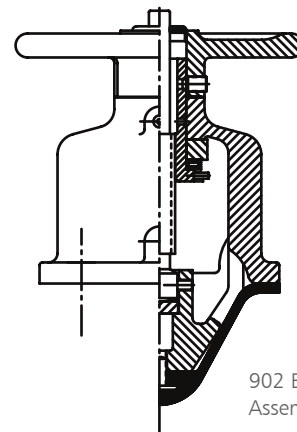

902 Bonnet Assembly

Manual Valve Bonnet Assembly Selections

O-Ring Sealed Bonnet

Provides a secondary seal which retains fluids or gases within the valve bonnet in the event of diaphragm failure. A standard sealed bonnet is recommended for hazardous materials which will not damage bonnet shell, bushing or spindle (stem). On corrosive fluids or gases, either non-sealed bonnets or in cases where the fluids or gases must be contained, more corrosion-resistant materials should be utilized. All sealed bonnets are provided with v-notch vent plugs to provide a safe and easy method of checking diaphragm integrity.

If a sealed bonnet is used and the bonnet assembly cannot handle the line media for a prolonged period of time, contact ITT for recommendations.

Handwheel Locking Device

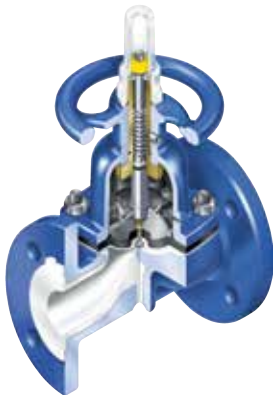

Secures valve in position so that it may not be operated unless unlocked and disengaged.

Chain Wheel Operated

Uses standard sprocket rim, guide and chain. Available 1/2"-12", weir or straightway.



Extended Stem

Available in all sizes. Not available with solid plastic bodies.



Direct Loaded Bonnet

An economical approach to automatic on-off operation. Ideal for multi-valve panel operation of batching systems, water and waste treatment systems. Furnished with or without pilot solenoid utilizing pneumatic or hydraulic operation. Available in sizes 1/2"-3" for pressures up to 100 psi. Suitable for all standard weir body materials. See Actuator section for details.



Other Available Options

Bonnet Assemblies of:

- Stainless Steel
- Ductile Iron
- Bronze
- PAS (Polyarylsulfone) Plastic

Gear Boxes

Especially suitable for large size valves with high line pressures this accessory reduces the amount of force required to manually operate the valve.

Vacuum Preparation

Dia-Flo® diaphragm valves are capable of bubble-tight shut-off down to 0.1 micron. Elastomer or PTFE diaphragms may be used. The standard weir valve design with elastomer diaphragm is capable of in-leakage of less than 1×10^{-6} atmcc/sec, and on special order it can be furnished with a substantially lower in-leak rate.



Finishes and Coatings

Finishes and Coatings for Manual and Automated Valves

Standard Primer

Dia-Flo® diaphragm valves are painted using a fast dry, lead free, Safety Blue primer. The prime coat is a dispersion resin modified medium oil alkyd developed for use on iron and aluminum. It is recommended that a suitable top coat be applied over the primer.



White Epoxy Coating

Dia-Flo® valves may be ordered using an optional decorative white epoxy coating when the appearance of your installation is important. White epoxy spray coating is applied using a primer and top coat to the valve body, bonnet shell, hand wheel and actuator when specified. Coating thickness is 4–10 mils. Valves ordered with white epoxy coatings include stainless steel fasteners.



PVDF Coating

Service life of valves that are installed in a corrosive atmosphere may be greatly extended by the use of PVDF coating. PVDF coatings provide atmospheric corrosion protection, particularly fume and splashing. Coating is applied to the body, bonnetshell, hand wheel, and actuator when specified. Coatings are a metallic gray dispersion coating that is applied using a minimum of three steps: a prime coat; an intermediate coat and a final coat. Coating thickness is 5-9 mils. Fasteners on PVDF coated valves are stainless steel.



Automated valve with PVDF Coating installed at power plant.

Section 3

Diaphragm Valve Actuation



Contained in this section:

- Pneumatic Actuation
- Types
- Features
- Sizing Charts
- Other Available Actuator Options

Dia-Flo[®] Pneumatic Actuators

Introduction

Dia-Flo[®] pneumatic actuators are rugged, durable and long lasting. Properly maintained, a service life of 20+ years is not uncommon. The actuator wear parts are limited to the nylon reinforced diaphragm and Buna N "O" rings that require infrequent replacement.

Modes of Operation

- On / Off control operation
- Automatic throttling

Design Features

- **Compact** – Close-coupled actuators combine minimum space with maximum economy.
- **Rugged** – Aluminum or ductile iron motor cases provide maximum strength.
- **Low Maintenance** – Only diaphragm and O-Ring seals need occasional replacement.
- **Efficient** – Seven interchangeable actuator sizes allow maximum efficiency of available power.
- **Minimum Number of Parts** – Enclosed and protected from atmospheric conditions.
- **Adaptability** – Suitable for pneumatic or hydraulic operation in various pressure ranges.
- **Flexibility** – Can be mounted on any manual valve body already in service.
- **Accessories** – Wide variety available, including: handwheel closing device, positioner, adjustable travel stop, position indicator, adjustable opening stop, limit switches and proximity switches.
- **Actuator diaphragm** – Molded, nylon reinforced oil resistant elastomer. Designed for long life at air pressures up to 85 psi.



Actuator Series

3100 Series

Fail Open (Spring-to-Open, Air-to-Close)

The actuator is spring-to-open, air-to-close type. Operation is via a normally closed 3 way, 2 position (3/2) solenoid valve. When the solenoid is energized, valve closes and when de-energized, the valve opens. The valve will fail open in the event of loss of electrical power to the solenoid valve.

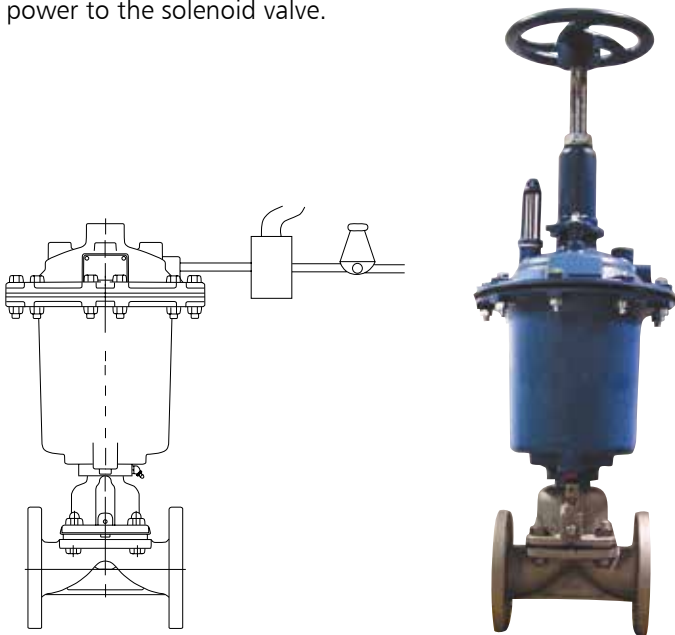

Piping Schematic for 3/2 Solenoid Valve Normally Closed

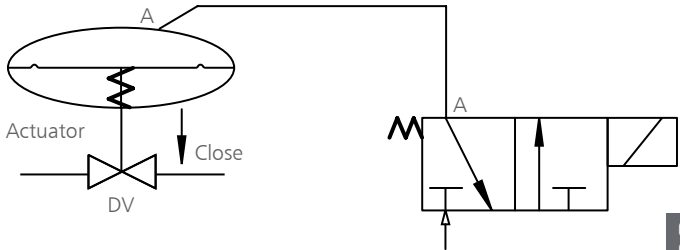

Air pressure on the top side of the actuator diaphragm closes the valve; a spring opens the valve. Springs are available to open valve against full vacuum in the line. (Be sure to specify when vacuum is involved.) The Dia-Flo® air to close, spring to open actuator is available in sizes #12, #25, #50, #101, #130, #250.

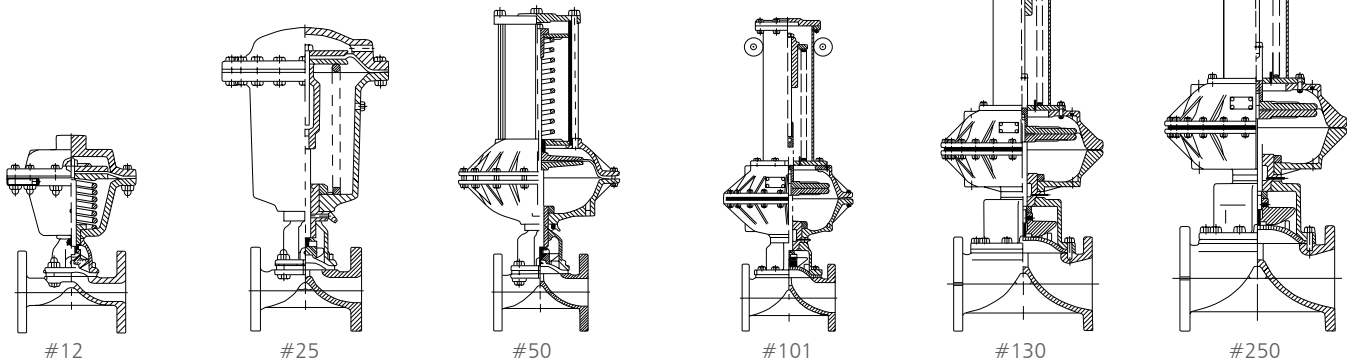

Sec 3: Actuation

Actuator Series

3200 Series

Fail Close (Spring-to-Close, Air-to-Open)

This is the reverse of the 3100 Series. The valve is spring-to-close and air-to-open. Operation is via a normally closed 3 way, 2 position (3/2) solenoid valve. When the solenoid is energized, the valve opens and when de-energized, the valve closes. The valve will fail closed in the event of loss of electrical power to the solenoid valve.

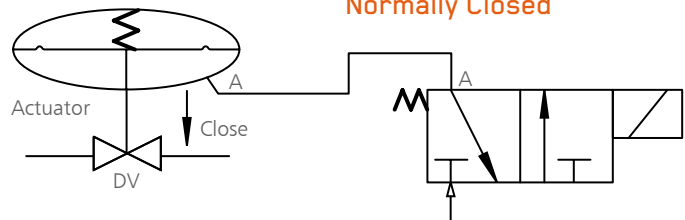
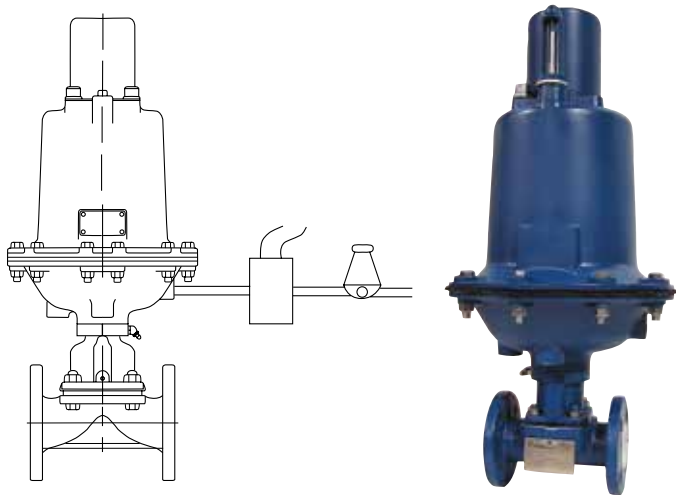

Piping Schematic
for 3/2 Solenoid Valve
Normally Closed

Air pressure on the underside of the actuator diaphragm opens the valve. A spring or set of springs closes the valve. This Dia-Flo® air-to-open / spring-to-close actuator is available in sizes #12, #25, #50, #75, #101, #130 and #250.

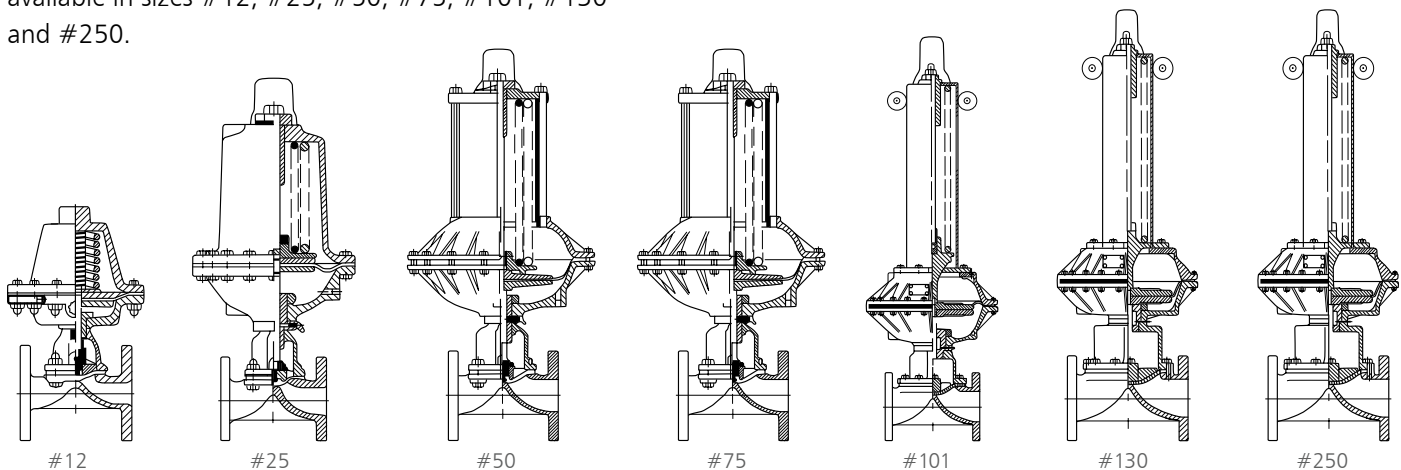

Actuator Series

3300 Series

Double Acting (Air-to-Close, Air-to-Open)

This type of actuator is similar in functionality as a double acting piston cylinder. Operation is via a 4 way, 2 position (4/2) solenoid valve. Standard set-up is valve closed when solenoid valve is de-energized and opens when energized. There is no fail position unless provided with an auxiliary source of air supply. Note that diaphragm valves will tend to open when line pressure is present.

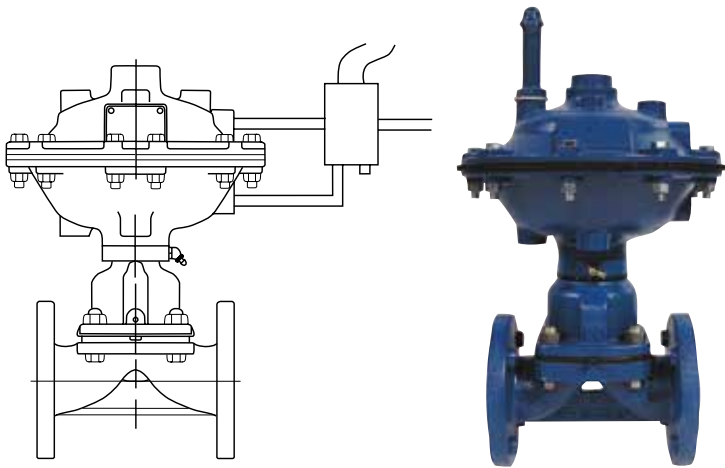

Piping Schematic for 4/2 Solenoid Valve

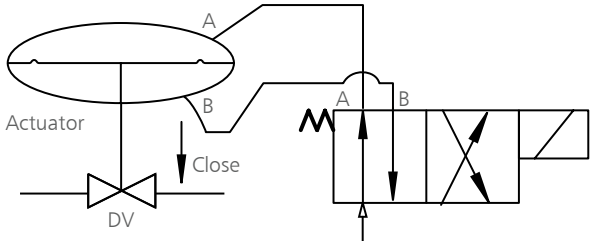

Double-acting (air-to-close, air-to-open) Dia-Flo® actuators are available in seven diaphragm sizes: #12, #25, #50, #75, #101, #130 and #250.

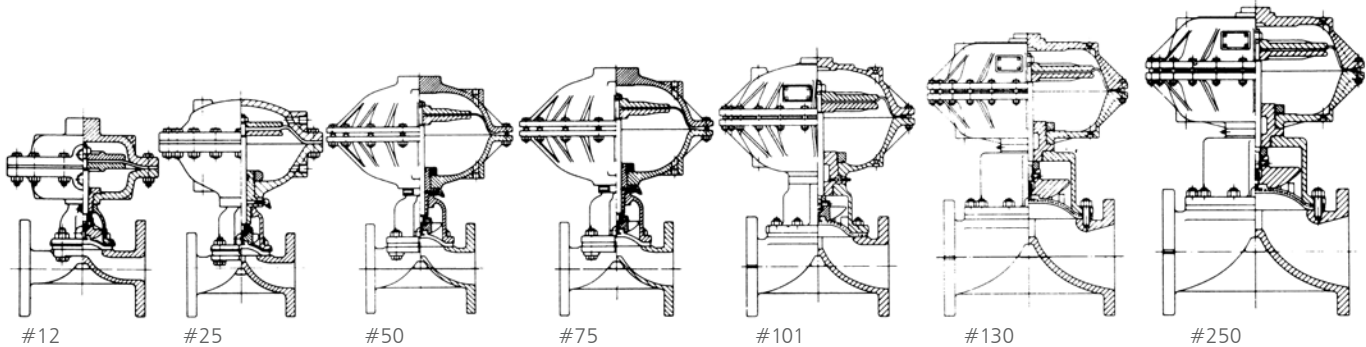

Actuator Series

3300 Series

Double Acting (Air-to-Close, Air-to-Open)

Alternatively, the valve can be controlled by means of two 3 way, 2 position (3/2) solenoid valves in lieu of one 4 way, 2 position (4/2) solenoid valve. In this arrangement, one solenoid valve is allowing air to one side of actuator chamber and the other solenoid valve is venting trapped air from the other chamber via the exhaust port.

Piping Schematic for Two (2) 3/2 Solenoid Valves

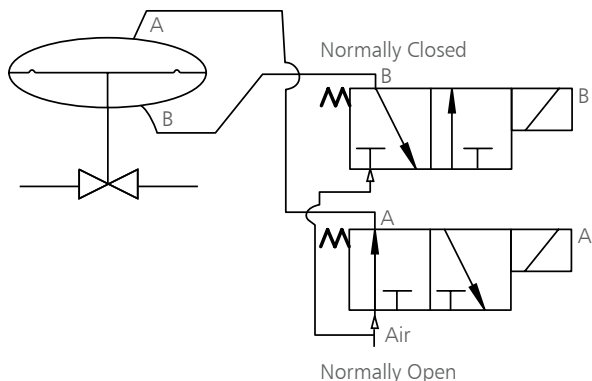

Piping Schematic for 4/2 Solenoid Valve with Auxiliary Air Pressure

In this schematic, snap acting relay is added to the control circuit and utilizing the normal air supply for pilot pressure source. This arrangement can be used to lock the actuator in its last position in the event of loss of pilot pressure but the auxiliary air source port will be plugged.

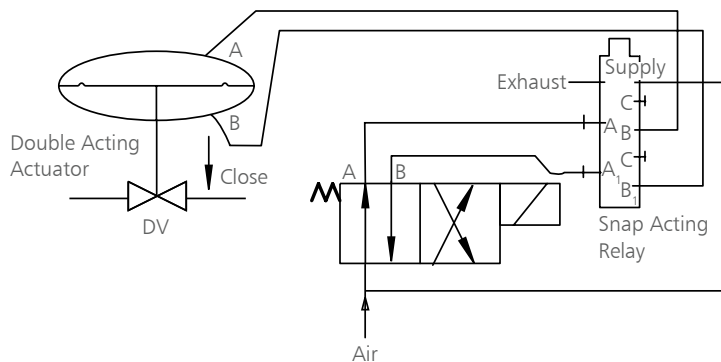

Note: We recommend use of dedicated air filter-regulator for each valve assembly because of different supply air pressure requirements.

This will extend valve diaphragm service life and keep speed of operation of valve unaffected by the fluctuating of supply air pressure.

Actuator Sizing

Sizing Parameters

The following information is necessary to properly size Dia-Flo® Diaphragm Valve Actuators:

1. Line Pressure: The fluid pressure in the pipeline against which the actuator must close the valve and remain leak tight.
2. Operating Pressure* or Electrical Requirements: The air or hydraulic pressure or Nema enclosure, amperage, phase and electrical voltage available to power the actuator

Diaphragm actuators are designed to operate with air pressures up to 85 psi. The maximum pressure differential between upper and lower chambers is also 85 psi.

*When pressure available for actuator exceeds required pressure to close valve, either the actuator should be supplied with a travel stop (closing travel limit) or pressure should be regulated down.

3. Pressure Drop: Two pressure drop conditions are recognized in industry for the purpose of valve selection. These are specified as either 0% or 100% ΔP (delta-P).

The system condition for 0% pressure drop applies when a valve is being closed against a maintained pressure on the inlet and outlet of the valve (Figure 1).

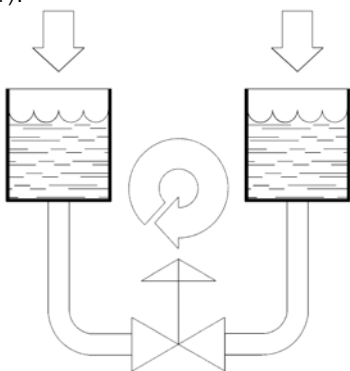

FIGURE 1: 0% PRESSURE DROP (ΔP)

When pressure is exerted on both sides of the diaphragm, more force is required to close the valve.

A second condition exists when the valve is closed before line pressure is applied to the inlet of the valve or if the valve has pressure on the inlet and outlet in the open position and as the valve closes, the pressure on the outlet reduces to no or low line pressure (Figure 2).

4. Valve Diaphragm Type: The valve diaphragm material can directly affect the required amount of thrust needed to shut a valve. Sizing charts are provided for both elastomer and PTFE diaphragms at both 100% or 0% ΔP .
5. Actuator Type: Fail closed, fail open or double acting. Available for both weir and straightway types.
6. Valve Size: Usually the same as the bore of the pipeline, in some cases the valve size is intentionally smaller to reduce flow through the pipeline.
7. Valve Body Style: Weir type or straightway are available.
8. On / Off or Control: The weir type valve is suitable for on / off and limited throttling applications. If control or throttling is required, refer to the Dualrange information contained in this section of the binder.
9. Size Range: With the variety of actuator sizes available, optimum selection can be made to match body style, line pressure, operating pressure and ΔP .

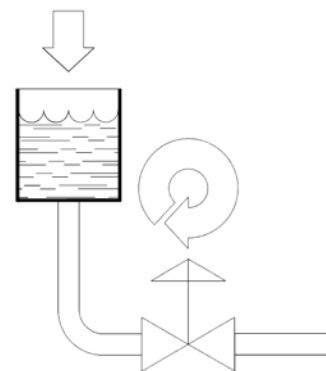

FIGURE 2: 100% PRESSURE DROP (ΔP)

When pressure is only on one side of the diaphragm and the outlet is open to atmospheric pressure less force is required to close the valve.

Actuator Sizing

Stroke

The stroke of an actuated valve is determined by the stroke of the valve **or** by the stroke of the actuator if the stroke of the actuator selected is less than the stroke of the valve. If the valve is "short stroked" by using an actuator with less stroke than the valve, full Cv rating of the valve may not be realized.



Weir Type Valve Stroke

ACTUATOR SIZE	12	25	50	75	101	130	250
Stroke	5/8"	2"	3"	3"	3 1/8"	3 1/2"	4 5/8"

Valve Size	1/2	3/4*	1	1 1/4 & 1 1/2	2	2 1/2	3	4	6	8	10	12
*Stroke	1/4"	3/8"	1/2"	13/16"	1 1/8"	1 3/8"	1 5/8"	2 1/8"	3 1/8"	4 5/8"	5 5/8"	6 1/2"

*Stroke for 3/4" flanged weir valve is 1/2" except solid plastic.

Straightway Valve Stroke

ACTUATOR SIZE	12	25	50	75	101	130	250
Stroke	5/8"	2"	3"	3"	3 1/8"	3 1/2"	4 5/8"

Valve Size	1	1 1/2	2	2 1/2	3	4	6	8	10	12
*Stroke	15/16"	1 1/4"	1 7/8"	2"	2 5/16"	2 13/16"	4 1/4"	6 1/4"	7 1/2"	7 1/2"

Air Requirements for Weir Type Valves

3100 Series Fail Open Actuators 100% ΔP
Air-to-Close, Spring-to-Open

3112

Chart A

No. 12 Actuator Spring to Open with **ELASTOMER** Diaphragm

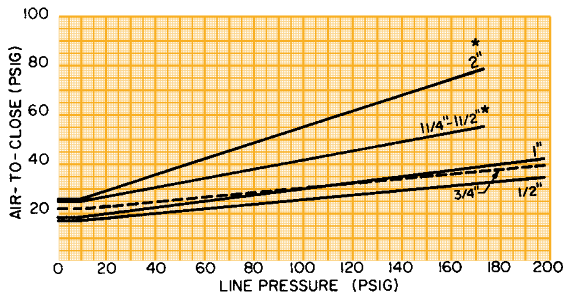

*Stroke limited to 5/8"

Chart B

No. 12 Actuator Spring to Open with **PTFE PLASTIC** Diaphragm

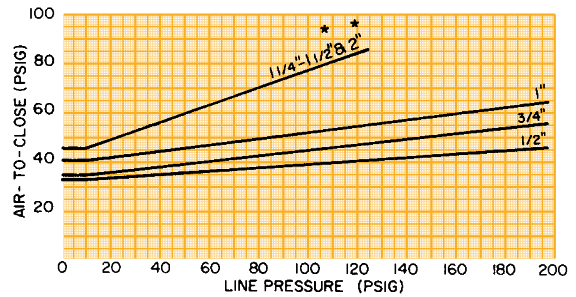

*Stroke limited to 5/8"

3125

Chart C

No. 25 Actuator Spring to Open with **ELASTOMER** Diaphragm

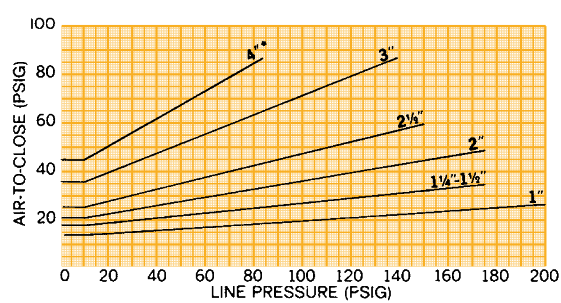

*Stroke limited to 2"

Chart D

No. 25 Actuator Spring to Open with **PTFE PLASTIC** Diaphragm

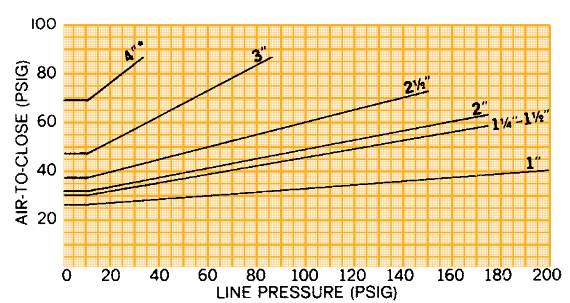

*Stroke limited to 2"

3150

Chart E

No. 50 Actuator Spring to Open with **ELASTOMER** Diaphragm

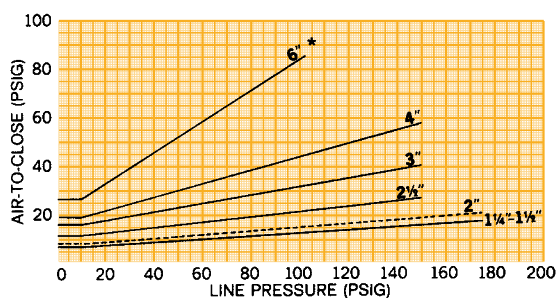

*Stroke limited to 3"

Chart F

No. 50 Actuator Spring to Open with **PTFE PLASTIC** Diaphragm

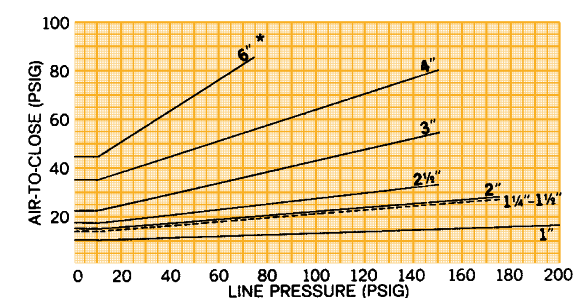

*Stroke limited to 3"

Sec 3: Actuation

Air Requirements for Weir Type Valves

3100 Series Fail Open Actuators 100% ΔP
Air-to-Close, Spring-to-Open

31101

Chart G
No. 101 Actuator Spring to Open with **ELASTOMER** Diaphragm

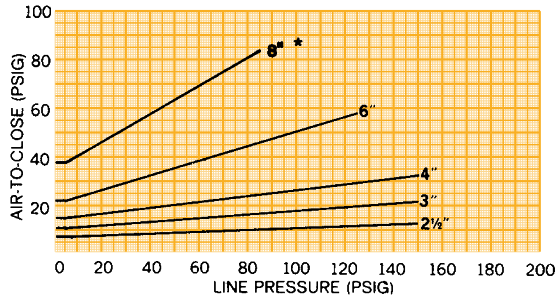

*Stroke limited to 3 1/8"

Chart H
No. 101 Actuator Spring to Open with **PTFE PLASTIC** Diaphragm

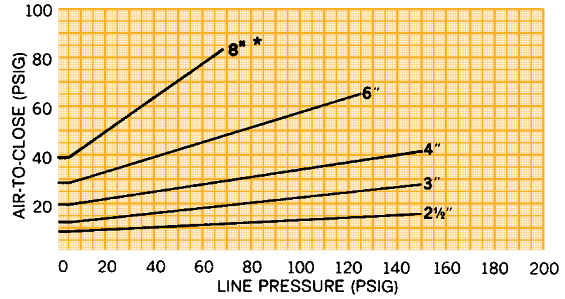

*Stroke limited to 3 1/8"

31130

Chart I
No. 130 Actuator Spring to Open with **ELASTOMER** Diaphragm

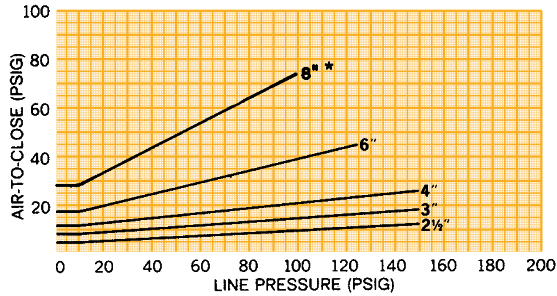

*Stroke limited to 3 1/2"

Chart J
No. 130 Actuator Spring to Open with **PTFE PLASTIC** Diaphragm

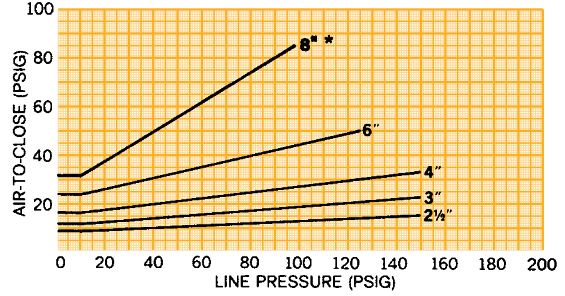

*Stroke limited to 3 1/2"

31250

Chart K
No. 250 Actuator Spring to Open with **ELASTOMER** Diaphragm

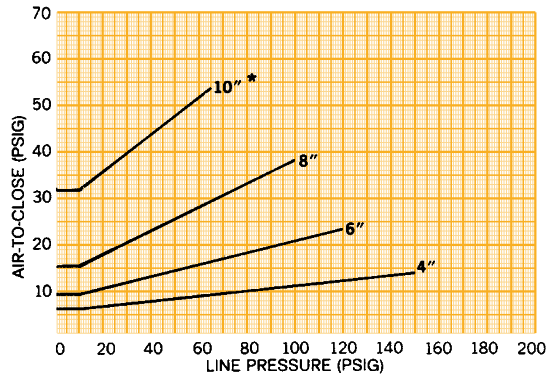

*Stroke limited to 4 5/8"

Chart L
No. 250 Actuator Spring to Open with **PTFE PLASTIC** Diaphragm

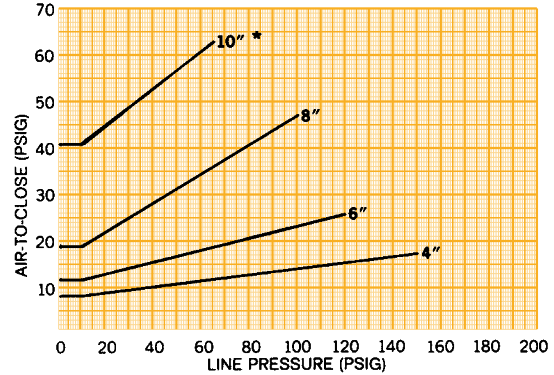

*Stroke limited to 4 5/8"

Air Requirements for Weir Type Valves

3200 Series Fail Close Actuators Air-to-Open, Spring-to-Close 100% ΔP Elastomer

Use chart to determine size and spring requirements.

Diaphragm Material	Actuator Size	Figure Number	Spring Number	Maximum line pressures (psi) at 100% PD (Bubble Tight Shut Off) Weir Type Valves											Air Required at Full Stroke at 0 psi Line ■									
				1/2"	3/4"	1"	1 1/4" & 1 1/2"	2"	2 1/2"	3"	4"	6"	8"	10"										
Elastomers (See next page for PTFE diaphragms)	#12	3216	89	60	30	60	20*																23	
		3213	88	200	170	65*	20*																	45
	#25	3214	88 & 89		200	200	95*																	60
		3228	102A		200		135	80	50	15														30
		3226	101				175	165	110	40	10													55
		3227	101 & 102A				175	175	150	85	35													85
	#50	3256	102A				100	45	35															17
		3251	101				175	110	70	20														26
	#50L	3252	101 & 102A				175	175	130	50														38
		3253	97				175	175	130	60	25													30
		3254	96				175	175	150	135	70	25												48
	#75	3255	96 & 97							150	110	40††												71
		3274	96							150	125	70	23††											29
		3276	96 & 97							150	150	120	40††											42
		3277	97 & 98							150	150	150	56††											47
		3278	96 & 98							150	150	150	73††											63
		3279	96, 97 & 98							150	150	150	89††											76
		32102	96							150	125	70	23											20
		32109	97							118	53	22												10
		32103	98							150	150	117	39											28
		#101	32104	96 & 97							150	150	120	40										
	32105		96 & 98							150	150	150	73											48
	32106		97 & 98							150	150	150	56											38
	32107		96, 97 & 98							150	150	150	89											58
#130	32108	130							150	150	150	125	46†										85	
	32132	96							150	125	70	23											16	
	32131	97							118	53	22												9	
	32133	98							150	150	117	39											23	
	32134	96 & 97							150	150	120	40											24	
	32135	96 & 98							150	150	150	73											39	
	32136	97 & 98							150	150	150	56											32	
	32137	96, 97 & 98							150	150	150	89											48	
	32138	130							150	150	150	125	46**										67	
	32253	130																					32	
#250	32252	129																					30	
	32251	129 & 130																					62	

• Stroke limited to 1/8" * Stroke limited to 3/16" ** Stroke limited to 3/16" † Stroke limited to 3/16" †† Stroke limited to 3" ■ In vacuum applications additional operating air pressure is required.

3200 Series Fail Close Actuators
Air-to-Open, Spring-to-Close
100% ΔP PTFE

Use chart to determine size and spring requirements.

Air Requirements for Weir Type Valves

Diaphragm Material	Actuator Size	Figure Number	Spring Number	Maximum line pressures (psi) at 100% PD (Bubble Tight Shut Off) Weir Type Valves											Air Required at Full Stroke at 0 psi Line ■			
				1/2"	3/4"	1"	1 1/4" & 1 1/2"	2"	2 1/2"	3"	4"	6"	8"	10"				
PTFE	#12	3213	88	50	20												45	
		3214	88 & 89	185	115	65	20*	20*										60
	#25	3228	102A	200	200	140	50	30	10									30
		3226	101			200	140	115	60	10								55
	#50	3227	101 & 102A				175	175	130	45								85
		3256	102A			120	25	15										17
	#50L	3251	101				90	80	30									26
		3252	101 & 102A				175	170	85	20								38
	#75	3253	97				150	135	80	25								30
		3254	96				175	175	150	85	20							48
	#75	3255	96 & 97											20	60	20††		71
		3274	96															29
	#75	3276	96 & 97								150	80	25					42
		3277	97 & 98								150	142	63			17††		47
	#75	3278	96 & 98								150	150	98			33††		63
		3279	96, 97 & 98								150	150	134			48††		76
	#101	32102	96								150	80	25					20
		32109	97								68	21						10
	#101	32103	98								150	133				16		28
		32104	96 & 97								150	142	63			17		30
#101	32105	96 & 98								150	150	134			48		48	
	32106	97 & 98								150	150	98			33		38	
#101	32107	96, 97 & 98								150	150	150			65		58	
	32108	130								150	150	150	120	120	38†		85	
#130	32132	96								150	80	25					16	
	32131	97								68	21						9	
#130	32133	98								150	133				16		23	
	32134	96 & 97								150	142	63			17		24	
#130	32135	96 & 98								150	150	134			48		39	
	32136	97 & 98								150	150	98			33		32	
#250	32137	96, 97 & 98								150	150	150			65		48	
	32138	130								150	150	120	120	38*			67	
#250	32253	130															32	
	32252	129															30	
#250	32251	129 & 130															62	
																	15**	

• Stroke limited to 3/4" † Stroke limited to 3 1/2" ** Stroke limited to 4 1/2" †† Stroke limited to 3" ■ In vacuum applications additional operating air pressure is required.

Air Requirements for Weir Type Valves

3300 Series Double Acting Actuators 100% ΔP Air-to-Open, Air-to-Close

If ordering an actuator with positioner, an air cushion regulator will be added to provide 10 psi in the lower chamber. Therefore, add 10 psi to the Air-to-Close value for minimum air required.

3312

Chart A
No. 12 Actuators with **ELASTOMER** Diaphragm

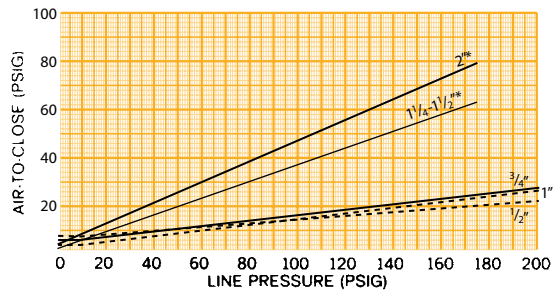

*Stroke limited to 5/8"

Chart B
No. 12 Actuators with **PTFE PLASTIC** Diaphragm

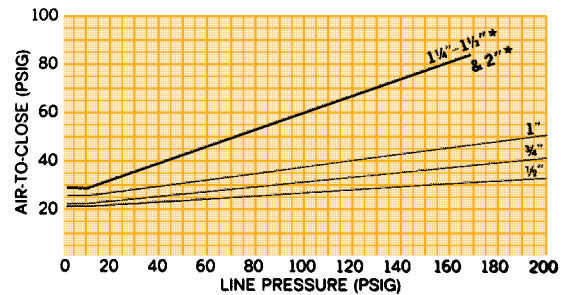

*Stroke limited to 5/8"

3325

Chart C
No. 25 ACTUATOR with **ELASTOMER** Diaphragm

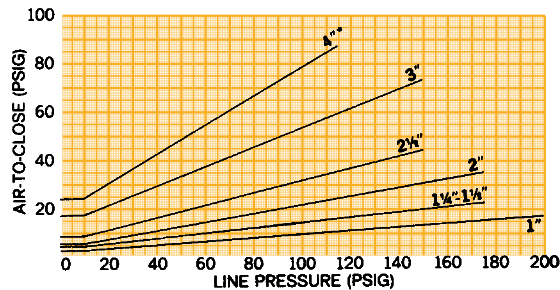

*Stroke limited to 2"

Chart D
No. 25 ACTUATOR with **PTFE PLASTIC** Diaphragm

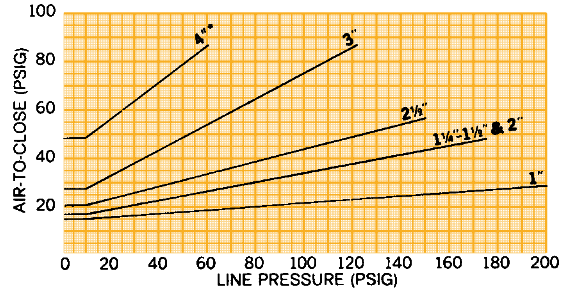

*Stroke limited to 2"

3350

Chart E
No. 50 ACTUATOR with **ELASTOMER** Diaphragm

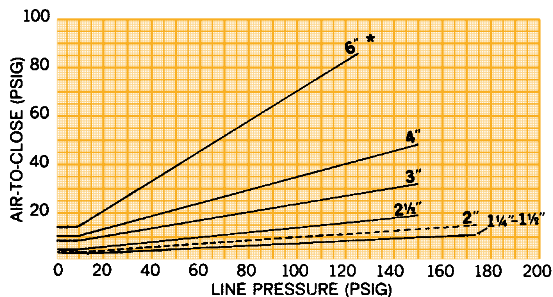

*Stroke limited to 3"

Chart F
No. 50 ACTUATOR with **PTFE PLASTIC** Diaphragm

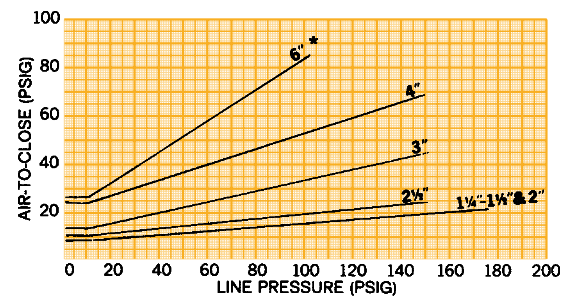

*Stroke limited to 3"

Air Requirements for Weir Type Valves

3300 Series Double Acting Actuators 100% ΔP Air-to-Open, Air-to-Close

If ordering an actuator with positioner, an air cushion regulator will be added to provide 10 psi in the lower chamber. Therefore, add 10 psi to the Air-to-Close value for minimum air required.

3375

Chart G
No. 75 ACTUATOR with ELASTOMER Diaphragm

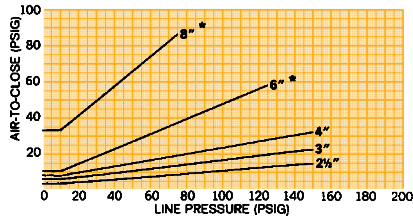

*Stroke limited to 3"

Chart H
No. 75 ACTUATOR with PTFE PLASTIC Diaphragm

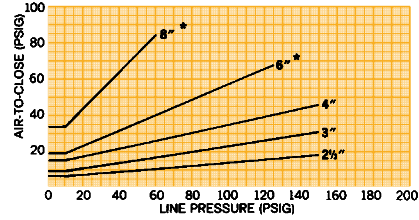

*Stroke limited to 3"

33101

Chart I
No. 101 Actuator with ELASTOMER Diaphragm

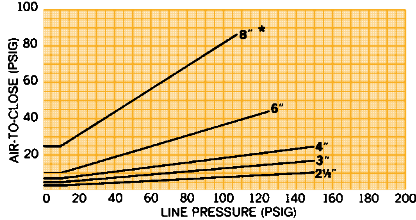

*Stroke limited to 3 1/2"

Chart J
No. 101 Actuator with PTFE PLASTIC Diaphragm

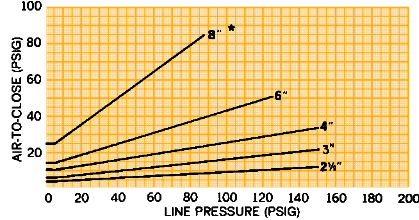

*Stroke limited to 3 1/2"

33130

Chart K
No. 130 Actuator with ELASTOMER Diaphragm

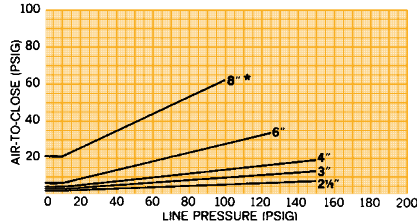

*Stroke limited to 3 1/2"

Chart L
No. 130 Actuator with PTFE PLASTIC Diaphragm

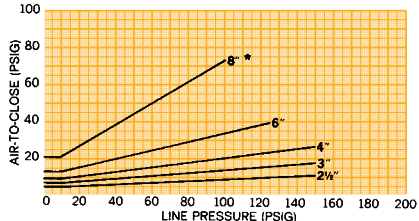

*Stroke limited to 3 1/2"

33250

Chart M
No. 250 Actuator with ELASTOMER Diaphragm

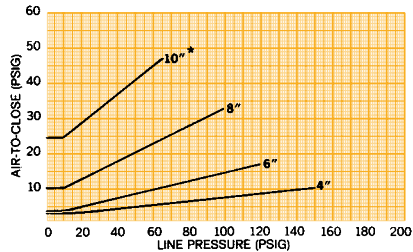

*Stroke limited to 4 3/4"

Chart N
No. 250 Actuator with PTFE PLASTIC Diaphragm

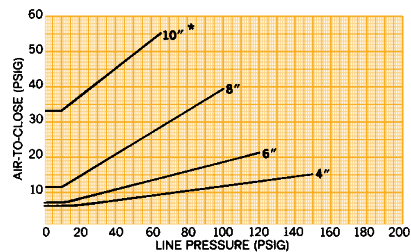

*Stroke limited to 4 3/4"

Air Requirements for Weir Type Valves

3100 Series Fail Open Actuators 0% ΔP
Air-to-Close, Spring-to-Open

3112

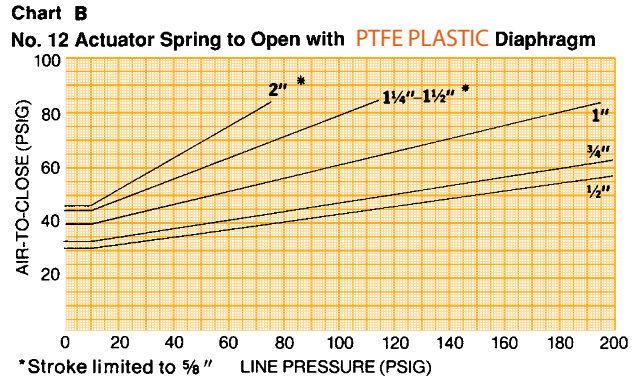
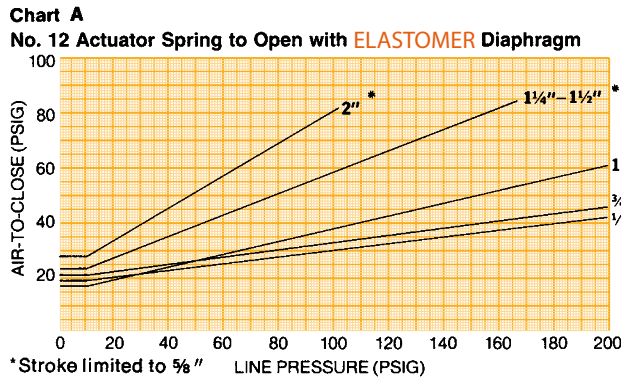

3125

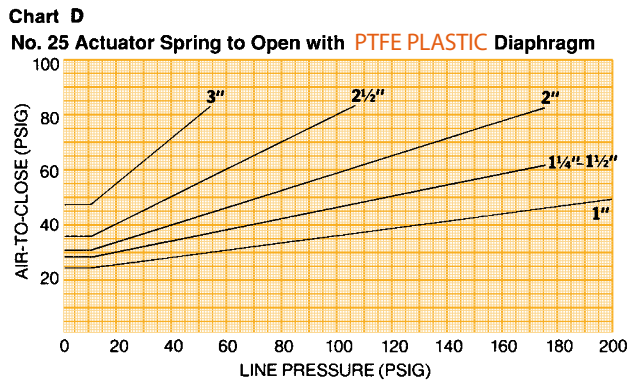
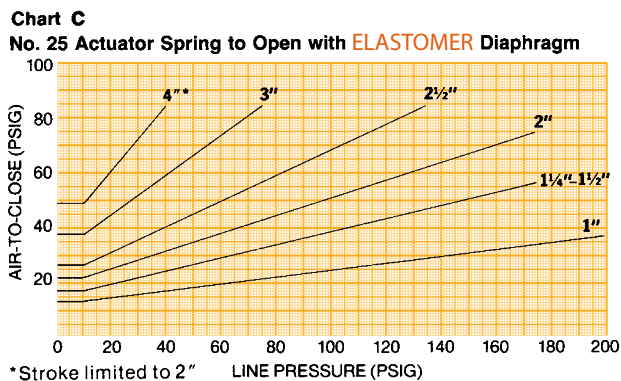

3150

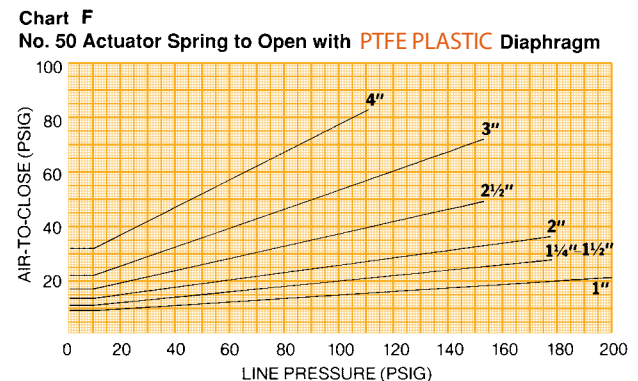
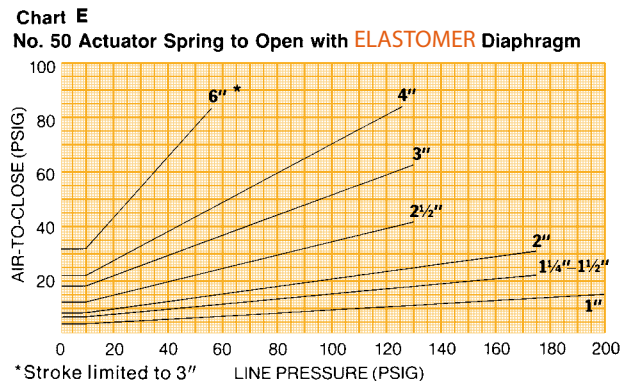

Air Requirements for Weir Type Valves

3100 Series Fail Open Actuators 0% ΔP
Air-to-Close, Spring-to-Open

3101

Chart G
No. 101 Actuator Spring to Open with **ELASTOMER** Diaphragm

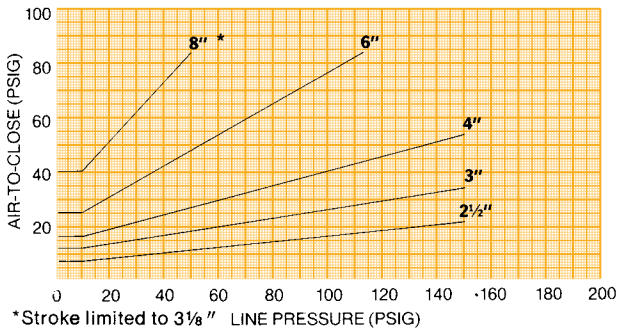
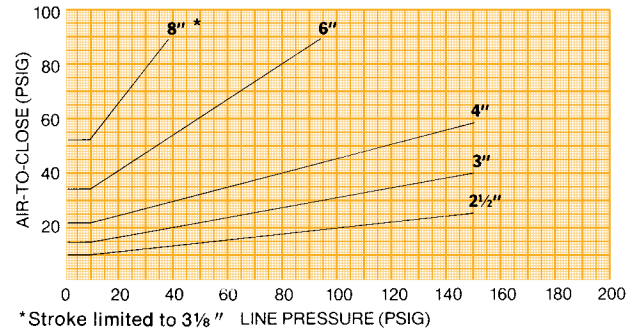

Chart H
No. 101 Actuator Spring to Open with **PTFE PLASTIC** Diaphragm



3130

Chart I
No. 130 Actuator Spring to Open with **ELASTOMER** Diaphragm

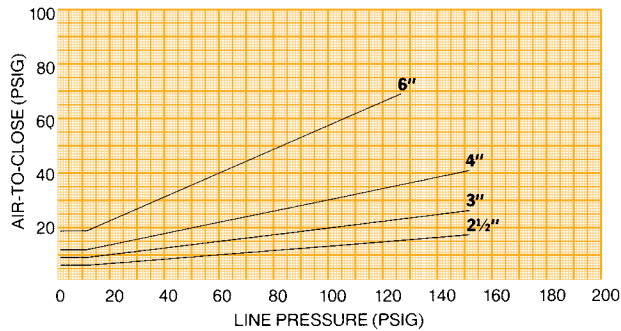
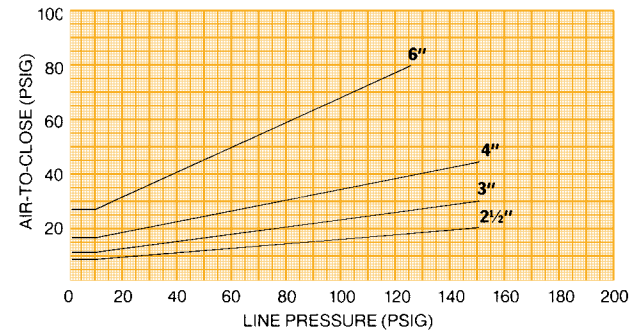

Chart J
No. 130 Actuator Spring to Open with **PTFE PLASTIC** Diaphragm



3250

Chart K
No. 250 Actuator Spring to Open with **ELASTOMER** Diaphragm

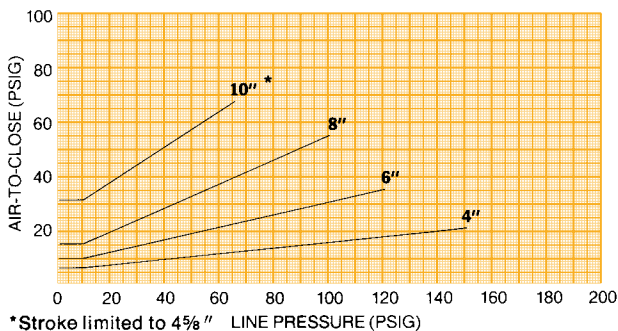
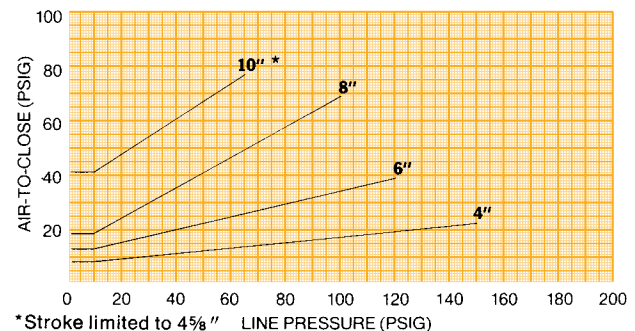

Chart L
No. 250 Actuator Spring to Open with **PTFE PLASTIC** Diaphragm



Air Requirements for Weir Type Valves

3200 Series Fail Close Actuators Air-to-Open, Spring-to-Close 0% ΔP Elastomer

Use chart to determine size and spring requirements.

Diaphragm Material	Actuator Size	Figure Number	Spring Number	Maximum line pressures (psi) at 0% PD (Bubble Tight Shut Off) Weir Type Valves										Air Required at Full Stroke at 0 psi Line ■							
				1/2"	3/4"	1"	1 1/4" & 1 1/2"	2"	2 1/2"	3"	4"	6"	8"		10"						
Elastomers (See next page for PTFE diaphragms)	#12	3216	89	25	15	35	10 •													23	
		3213	88	160	135	100	35 •	10 •													45
	#25	3214	88 & 89	200	200	145	65 •	30 •													60
		3228	102A	200	200	200	95	40	25												30
	#50	3226	101				165	85	55	20											55
		3227	101 & 102A				175	160	95	45	15										85
	#50L	3256	102A			160	70	25	15												17
		3251	101			200	125	60	35												26
	#75	3252	101 & 102A			200	175	110	65	25											38
		3253	97			200	170	100	65	30	10										30
	#101	3254	96				175	175	130	70	35	10*									48
		3255	96 & 97						150	120	55	20*									71
	#130	3274	96						125	70	31	12*									29
		3276	96 & 97						150	113	60	22*									42
	#250	3277	97 & 98						150	150	80	30*									47
		3278	96 & 98						150	150	103	39*									63
	#10	3279	96, 97 & 98						150	150	127	44*									76
		32102	96						120	65	35	10									20
	#130	32109	97						55	25	10										10
		32103	98						150	105	55	20									28
#250	32104	96 & 97						150	110	55	20									30	
	32105	96 & 98						150	150	100	35									48	
#130	32106	97 & 98						150	150	80	30									38	
	32107	96, 97 & 98						150	150	125	45									58	
#10	32108	130						150	150	150	80	30†								85	
	32132	96						120	65	35	10									16	
#130	32131	97						55	25	10										9	
	32133	98						150	105	55	20									23	
#250	32134	96 & 97						150	110	55	20									24	
	32135	96 & 98						150	150	100	35									39	
#130	32136	97 & 98						150	150	80	30									32	
	32137	96, 97 & 98						150	150	125	45									48	
#10	32138	130						150	150	150	80	30**								67	
	32252	129								150	85	26								30	
#130	32253	130								150	80	22								32	
	32251	129 & 130								150	125	65	25††							62	

• Stroke limited to 1/2" **Stroke limited to 3/4" †Stroke limited to 3/4" ††Stroke limited to 4/4" ■ In vacuum applications additional operating air pressure is required.

3200 Series Fail Close Actuators
Air-to-Open, Spring-to-Close
0% ΔP PTFE

Use chart to determine size and spring requirements.

Air Requirements for Weir Type Valves

Diaphragm Material	Actuator Size	Figure Number	Spring Number	Maximum line pressures (psi) at 0% PD (Bubble Tight Shut Off) Weir Type Valves											Air Required at Full Stroke at 0 psi Line				
				1/2"	3/4"	1"	1 1/4" & 1 1/2"	2"	2 1/2"	3"	4"	6"	8"	10"					
PTFE	#12	3213	88	50														45	
		3214	88 & 89	130	100	45	20*	10*											60
		3228	102A	200	200	105	40	25											30
	#25	3226	101			200	125	70	30										55
		3227	101 & 102A				175	140	70	15									85
		3256	102A			55	15												17
	#50	3251	101				60	40	15										26
		3252	101 & 102A				170	90	40	10									38
	#50L	3253	97				110	80	45	15									30
		3254	96				175	175	105	50	10								48
		3255	96 & 97						150	95	35								71
	#75	3274	96						99	51	11								29
		3276	96 & 97						150	90	40								42
		3277	97 & 98						150	124	62				15*				47
		3278	96 & 98						150	150	86				23*				63
		3279	96, 97 & 98						150	150	111				32*				76
	#101	32102	96						95	45	10								20
		32109	97						35	10									10
		32103	98						150	80	35								28
		32104	96 & 97						150	90	35								30
		32105	96 & 98						150	150	85				20				48
		32106	97 & 98						150	120	60				15				38
		32107	96, 97 & 98						150	150	110				30				58
32108		130						150	150	150				60		22†		85	
32132		96						95	45	10								16	
32131		97						35	10									9	
#130	32133	98						150	80	35								23	
	32134	96 & 97						150	90	35								24	
	32135	96 & 98						150	150	85				20				39	
	32136	97 & 98						150	120	60				15				32	
	32137	96, 97 & 98						150	150	110				30				48	
	32138	130						150	150	150				60		22**		67	
	32252	129								150				65		25		30	
#250	32253	130								150				60		15		32	
	32251	129 & 130								150				125		53		62	

• Stroke limited to 3/8" † Stroke limited to 3/16" ** Stroke limited to 4 1/2" †† Stroke limited to 3" ■ In vacuum applications additional operating air pressure is required.

Air Requirements for Weir Type Valves

3300 Series Double Acting Actuators 0% ΔP Air-to-Open, Air-to-Close

If ordering an actuator with positioner, an air cushion regulator will be added to provide 10 psi in the lower chamber. Therefore, add 10 psi to the Air-to-Close value for minimum air required.

3312

Chart A
No. 12 Actuator with ELASTOMER Diaphragm

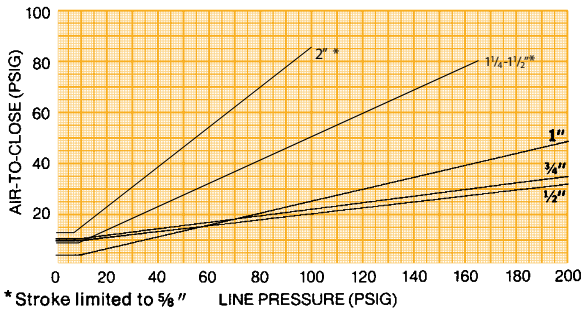
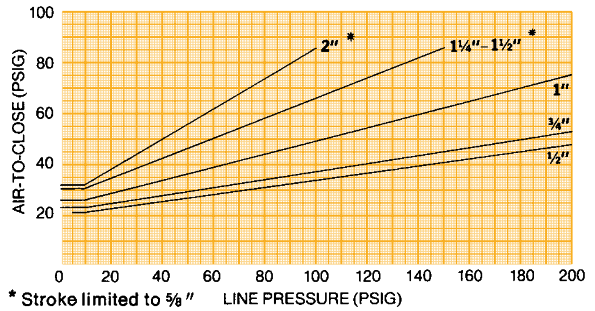

Chart B
No. 12 Actuator with PTFE PLASTIC Diaphragm



3325

Chart C
No. 25 Actuator with ELASTOMER Diaphragm

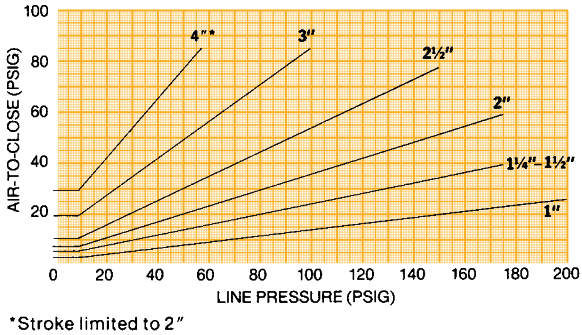
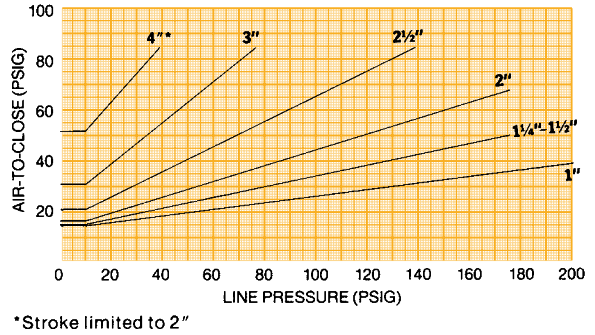

Chart D
No. 25 Actuator with PTFE PLASTIC Diaphragm



3350

Chart E
No. 50 Actuator with ELASTOMER Diaphragm

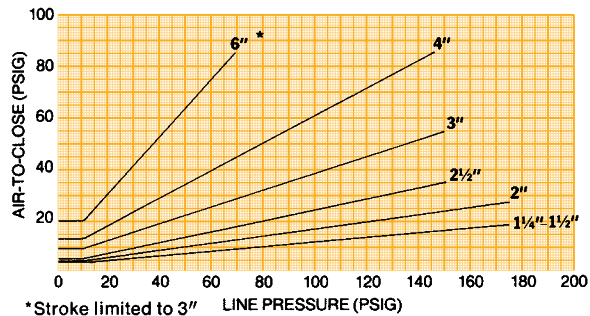
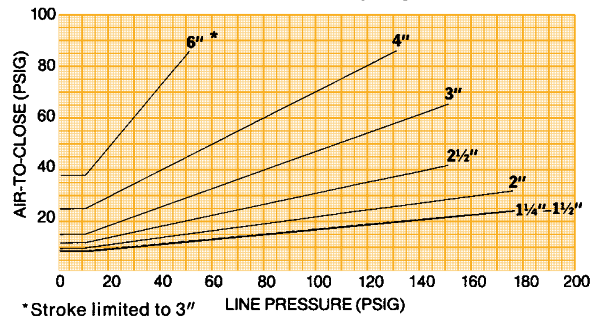

Chart F
No. 50 Actuator with PTFE PLASTIC Diaphragm



Air Requirements for Weir Type Valves

3300 Series Double Acting Actuators 0% ΔP Air-to-Open, Air-to-Close

If ordering an actuator with positioner, an air cushion regulator will be added to provide 10 psi in the lower chamber. Therefore, add 10 psi to the Air-to-Close value for minimum air required.

3375

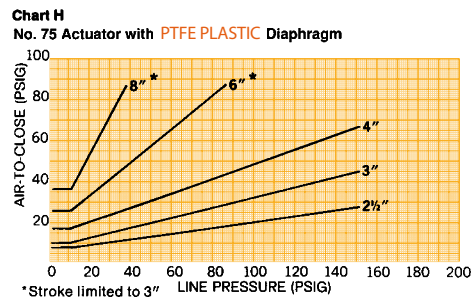
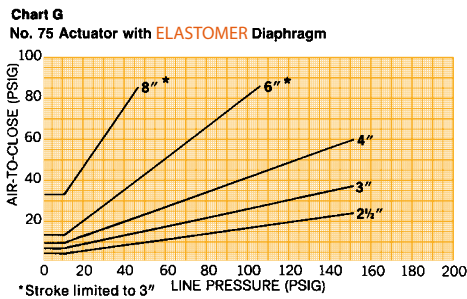

33101

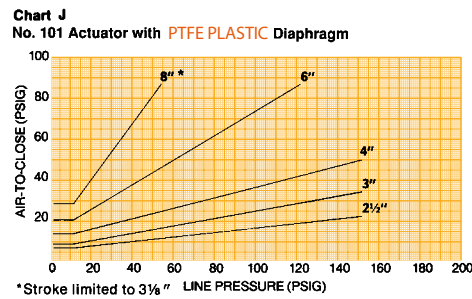
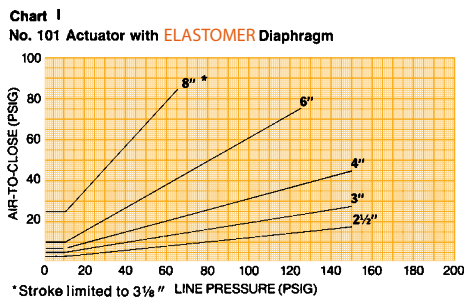

33130

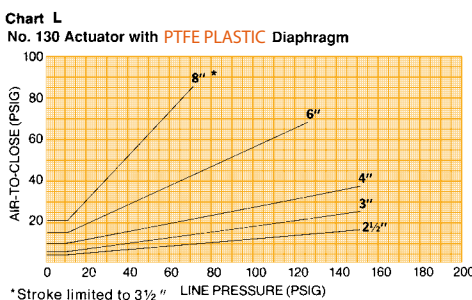
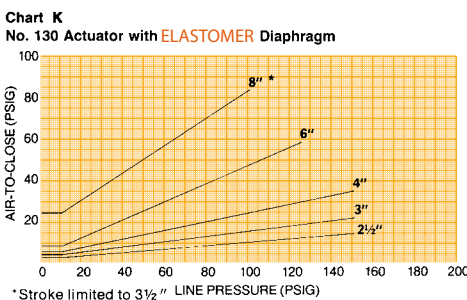

33250

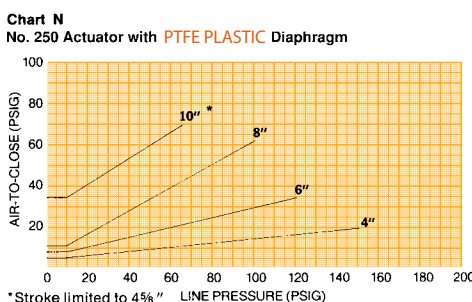
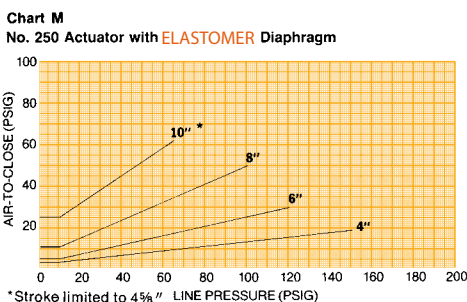

Dualrange Control for Fine Throttling Service

Dualrange Weir Type Bonnet Assemblies



Sec 3: Actuation

Dualrange Control for Fine Throttling Service

Principle of Operation

The superior performance of the Dualrange® Control Valve is the result of a simple yet effective innovation in diaphragm valve design: a two-piece compressor.

The two-piece compressor design not only permits greater rangeability in the valve, hence improved flow control, but provides porting which is more conducive to streamlined flow. This type of opening can handle slurries without excessive abrasion, dewatering or wiredrawing. The Dualrange should be supplied whenever precise throttling is required.

How It Works

During the initial movement of the valve stem, only the inner compressor moves. This permits smaller increases in flow for the same increase in stroke resulting in better modulation than conventionally designed diaphragm valves. Because the valve can now control within desired parameters more accurately, it is better able to create the desired flow conditions or pressure drop through the valve and avoid control valve hunting.

When the inner compressor is open to its limit, the outer compressor begins to open. From this point on, both compressors move as a unit. When wide open, the Dualrange provides the same full flow capacities as the conventional weir type designs.

The advantages gained in flow control by this design over the conventional diaphragm valve can be seen in the charts on the following page.

Because the Dualrange Control Valve must be able to position itself in an infinite range of positions from full open to full closed and hold these positions, it must be used in conjunction with a positioner. The positioner is the device that modulates the plant air to the valve operator in relation to the instrument air signal being fed by a control device.

Dualrange vs Conventional Weir Valve

FINE THROTTLING

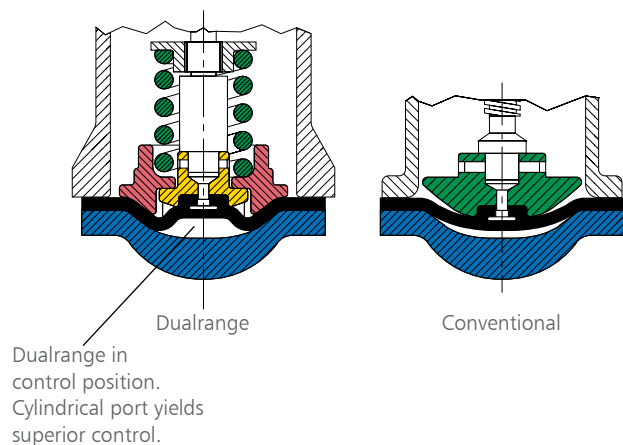

FULL OPEN

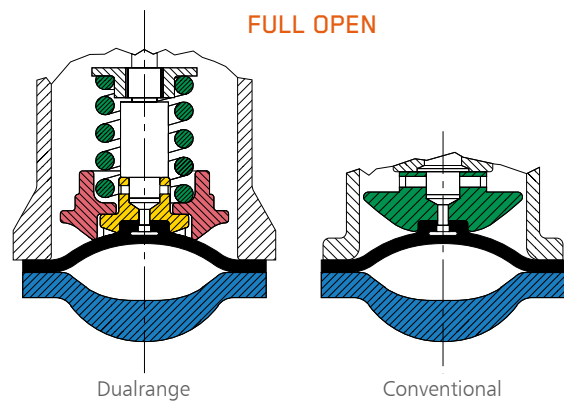

Dualrange Control for Fine Throttling Service

Applications

The Dualrange Control Valve is designed to operate at a maximum line pressure of 100 psi (689 kPa) and is recommended for use with the Dia-Flo® weir type diaphragm for applications as follows:

- Where a cost effective control valve is required on corrosive services.
- Where abrasives reduce valve life on throttling applications.
- Wherever positive closure and/or fine throttling are required in a control application.
- Where slurries may clog ordinary diaphragm valves when throttling.
- Where valves large enough to handle normal process flows cannot throttle low enough to control small amounts of flow required during start-up operations.
- Where split-ranging has been necessary to provide rangeability not available in a single diaphragm valve.

Dualrange Valve Notes

- For use on weir type valves only
- Positioners are required
- Maximum line pressure is 100 psi
- Available size range 1"–6"

Valve Flow Characteristics

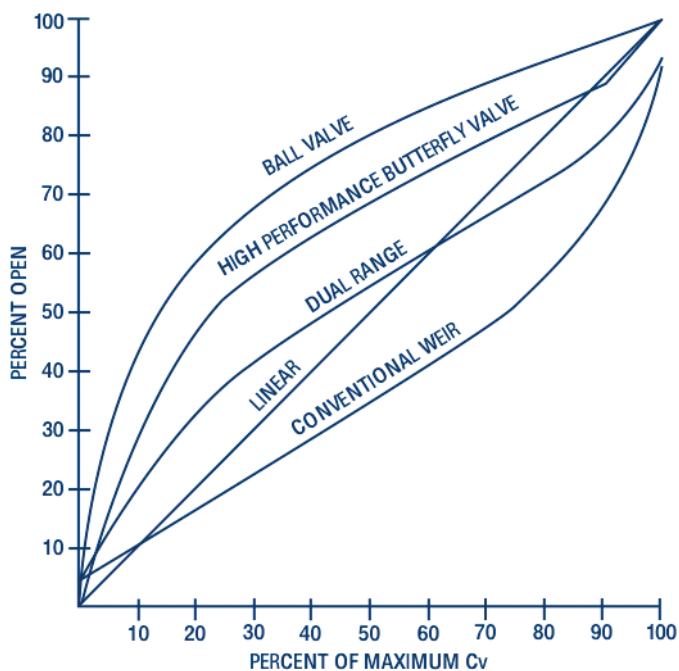
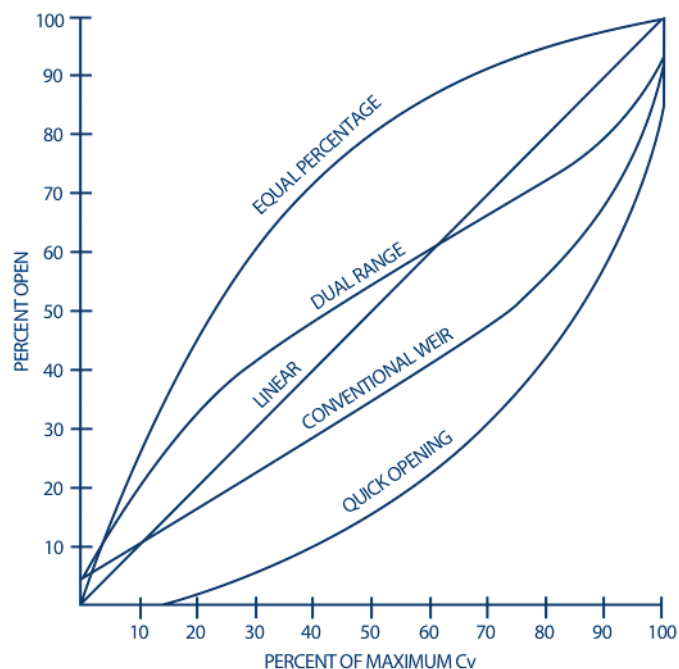

Dualrange Control for Fine Throttling Service

Control Systems

Dualrange Control Valves are used in a variety of throttling applications where fine control is required. Typical applications include flow control, level control, back pressure control and many others. The Dualrange, however, is merely a single component in a complex system known as the control loop.

In order to properly apply the Dualrange Control Valve, it is important to understand not only how the control loop works, but also what is trying to be accomplished downstream of the valve. The following schematic shows a typical single valve control loop.

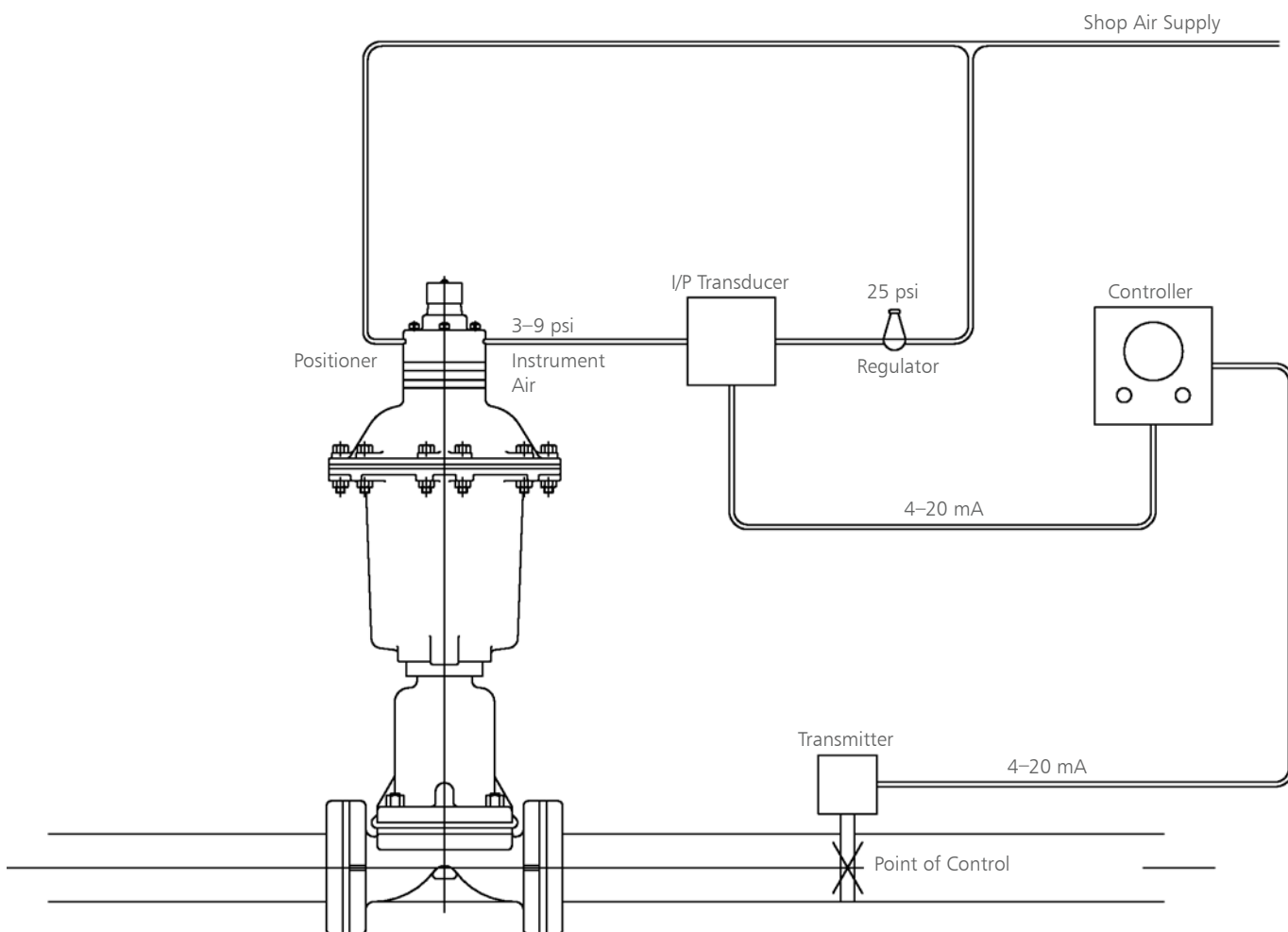

Dualrange Control for Fine Throttling Service

Sizing a Dualrange Control Valve

Dia-Flo® Dualrange valves are modulating control valves. As a result, precautions must be taken in sizing and selecting the valve versus an on-off valve. The following information must be known:

1. **Fluid** – Description of fluid including type of fluid, solids content, abrasive nature, etc.
2. **Concentration** – This would include chemical concentration and solids concentration.
3. **Specific Gravity**
4. **Flow Rate** – It is important when sizing a control valve to have the minimum, maximum and normal flow rates.
5. **Pressure Drop** – To be taken across valve, also known as delta-P or ΔP . It's important to have minimum, maximum and normal also.
6. **Instrument Signal or Control Signal** – This would normally be a 3–15 psi control signal. Other pneumatic signals are available such as 6–30, 3–9, etc. In addition, electronic signals are available such as 4–20 mA (milliamp).
7. **Line Size** – When the above information is available, the proper valve size can be determined. You may use the flow formulas that appear in the technical section of this binder. The diaphragm valve is sensitive to two conditions in a throttling situation. After you have determined valve size the following two tests must be done:
 - **Pressure Drop (ΔP) Across Valve** – The internal flow path of a diaphragm valve closely approximates the design of a high recovery valve. The valve is not designed to withstand large pressure drops. To avoid cavitation, ΔP shall be limited to 25% of P1 absolute (P1a). P1a = inlet gage pressure plus 14.7.
 - **Velocity Over the Weir Area** – For optimum performance, velocity over the weir should be limited to 15–20 fps (feet per second) for clear fluids and 8–10 fps for light slurries. See the technical section of this binder for area over the weir and velocity equation.



Air Requirements for Weir Type Dualrange Valves

3100 Series Fail Open Actuators 100% ΔP
Air-to-Close, Spring-to-Open

3112

Chart M
No. 12 (-84 3112) actuator with **ELASTOMER** Diaphragm

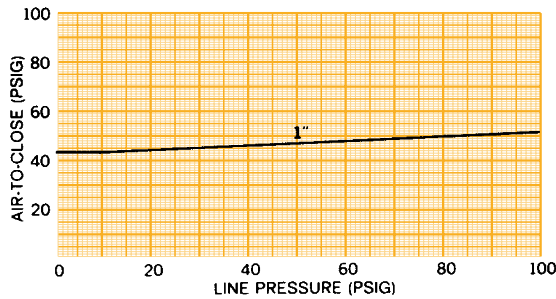
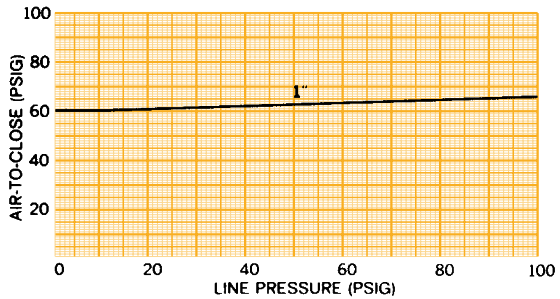

Chart N
No. 12 (-84 3112) actuator with **PTFE PLASTIC** Diaphragm



3125

Chart O
No. 25 (-84 3125) actuator with **ELASTOMER** Diaphragm

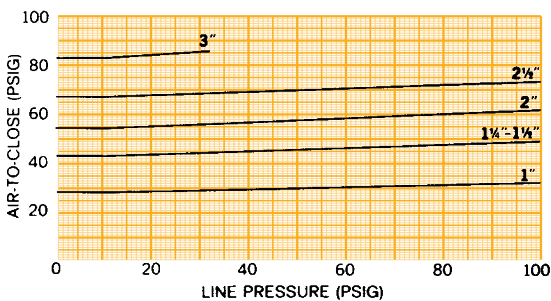
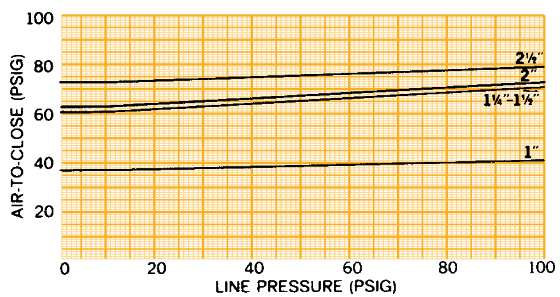

Chart P
No. 25 (-84 3125) actuator with **PTFE PLASTIC** Diaphragm



3150

Chart Q
No. 50 (-DR 3150) actuator with **ELASTOMER** Diaphragm

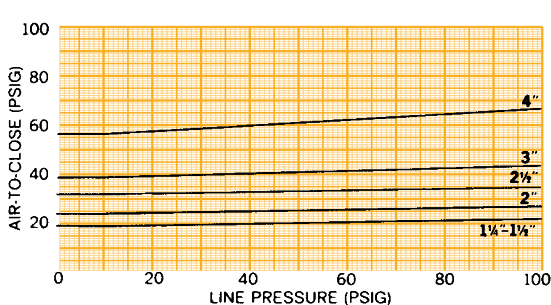
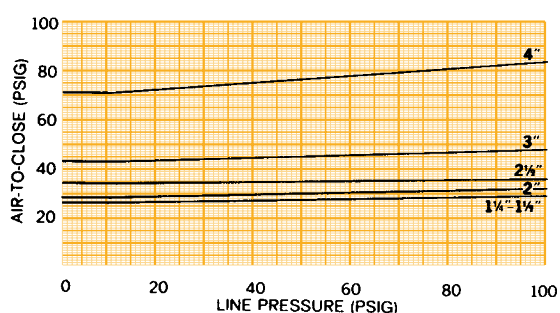

Chart R
No. 50 (-DR 3150) actuator with **PTFE PLASTIC** Diaphragm



Air Requirements for Weir Type Dualrange Valves

3100 Series Fail Open Actuators 100% ΔP
Air-to-Close, Spring-to-Open

31101

Chart S
No. 101 (-84 31101) actuator with **ELASTOMER** Diaphragm

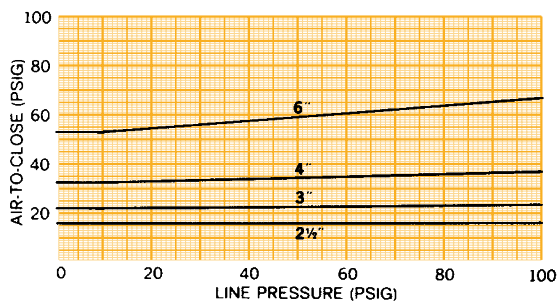
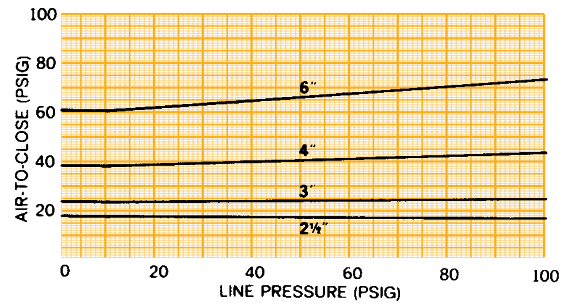

Chart T
No. 101 (-84 31101) actuator with **PTFE PLASTIC** Diaphragm



31130

Chart U
No. 130 (-84 31130) actuator with **ELASTOMER** Diaphragm

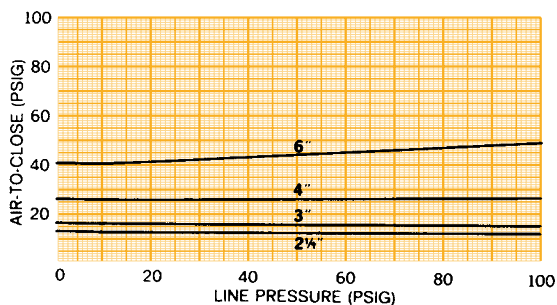
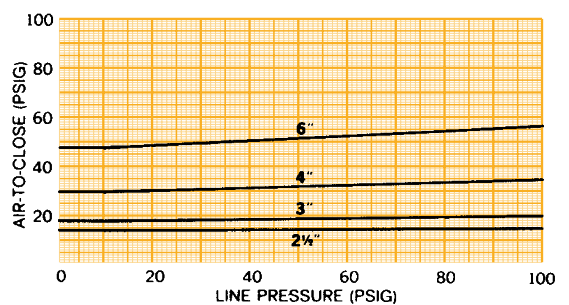

Chart V
No. 130 (-84 31130) actuator with **PTFE PLASTIC** Diaphragm



3200 Series Fail Close Actuators
Air-to-Open, Spring-to-Close
100% ΔP Dualrange Elastomer

Use chart to determine size and spring requirements.

Air Requirements for Weir Type Dualrange Valves

Diaphragm Material	Actuator Size	Figure Number	Spring Number	Maximum line pressures (psi) (Bubble Tight Shut Off) Dualrange Valves at 100% ΔP							Air Required to open psig		
				1"	1 1/2" & 1 1/2"	2"	2 1/2"	3"	4"	6"			
(See next page for PTFE diaphragms) Elastomers	#12	3214	88 & 89	70								75	
	#25	3228	102A	100									30
		3226	101		100								55
		3227	101 & 102A		100	25							85
	#50	3256	102A	100									12
		3251	101		40								19
	#50L	3252	101 & 102A		100	55							31
		3253	97		100	15							30
		3254	96			100							47
		3255	96 & 97			100	20						68
		3274	96				100						29
	#75	3277	97 & 98				100			52			47
		3278	96 & 98				100			100			63
	#101	32102	96				100						20
		32104	96 & 97				100						30
		32105	96 & 98				100			100			48
		32106	97 & 98				100			52			38
		32107	96, 97 & 98				100			100			58
	#130	32108	130				100			100		83	85
32132		96				100						16	
32134		96 & 97				100						24	
32135		96 & 98				100			100			39	
32136		97 & 98				100			52			32	
32137		96, 97 & 98				100			100			48	
#250	32138	130				100			100		83	67	
	32252	129				100					100	30	

Air Requirements for Weir Type Dualrange Valves

3200 Series Fail Close Actuators
Air-to-Open, Spring-to-Close
100% ΔP Dualrange PTFE

Use chart to determine size and spring requirements.

Diaphragm Material	Actuator Size	Figure Number	Spring Number	Maximum line pressures (psi) @ 0% PD (Bubble Tight Shut Off) Weir Type Valves							Air Required at Full Stroke at 0 psi Line		
				1"	1 1/2" & 1 1/2"	2"	2 1/2"	3"	4"	6"			
PTFE	#25	3228	102A	50								30	
		3226	101	100								55	
		3227	101 & 102A		100	100							85
	#50	3251	101	100									19
		3252	101 & 102A		40								31
	#50L	3254	96		100	100							47
		3255	96 & 97				100						68
	#75	3274	96				100	100					29
		3277	97 & 98				100	100	100				47
		3278	96 & 98				100	100	100	40			63
		3279	96, 97 & 98				100	100	100	100			76
		32102	96				100	100	100				20
	#101	32104	96 & 97				100	100	100				30
		32105	96 & 98				100	100	100	40			48
		32106	97 & 98				100	100	100				38
		32107	96, 97 & 98				100	100	100	100	100		58
		32108	130				100	100	100	100	100	30	85
	#130	32132	96				100	100	100				16
		32133	98				100	100	100				23
		32134	96 & 97				100	100	100				24
32135		96 & 98				100	100	100	40			39	
32136		97 & 98				100	100	100				32	
32137		96, 97 & 98				100	100	100	100			48	
32138		130				100	100	100	100	100	30	67	
32251	129 & 130									100	62		

Air Requirements for Weir Type Dualrange Valves

3300 Series Double Acting Actuators 100% ΔP Air-to-Open, Air-to-Close

If ordering an actuator with positioner, an air cushion regulator will be added to provide 10 psi in the lower chamber. Therefore, add 10 psi to the Air-to-Close value for minimum air required.

3312

Chart A
No. 12 (-84 3312) actuator with **ELASTOMER** Diaphragm

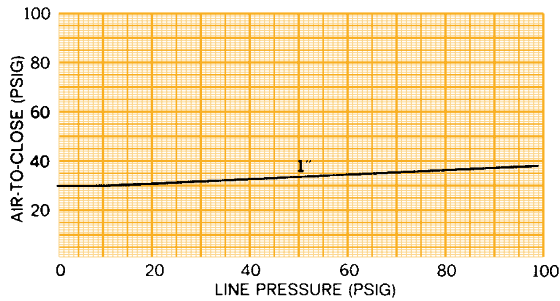
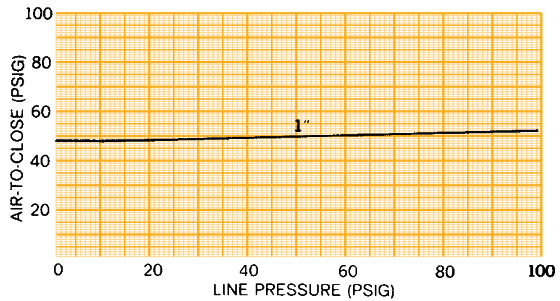

Chart B
No. 12 (-84 3312) actuator with **PTFE PLASTIC** Diaphragm



3325

Chart C
No. 25 (-84 3325) actuator with **ELASTOMER** Diaphragm

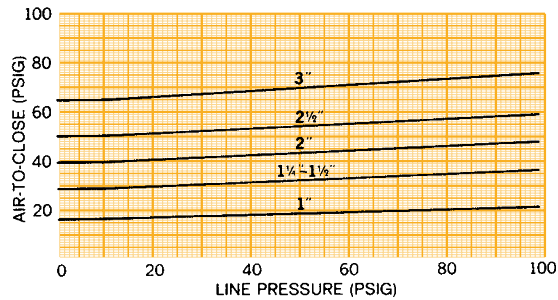
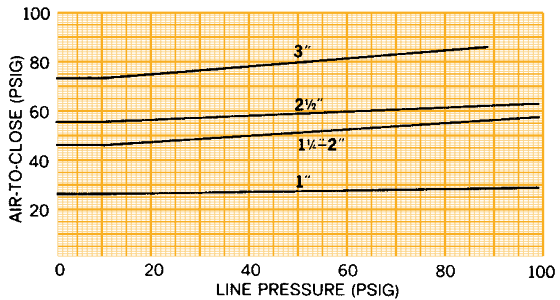

Chart D
No. 25 (-84 3325) actuator with **PTFE PLASTIC** Diaphragm



3350

Chart E
No. 50 (-84 3350) actuator with **ELASTOMER** Diaphragm

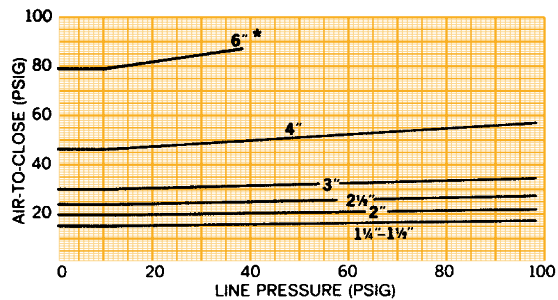
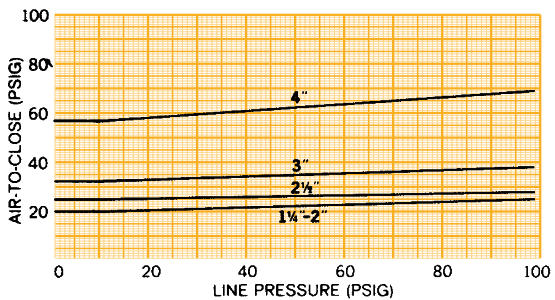

Chart F
No. 50 (-84 3350) actuator with **PTFE PLASTIC** Diaphragm



Air Requirements for Weir Type Dualrange Valves

3300 Series Double Acting Actuators 100% ΔP Air-to-Open, Air-to-Close

If ordering an actuator with positioner, an air cushion regulator will be added to provide 10 psi in the lower chamber. Therefore, add 10 psi to the Air-to-Close value for minimum air required.

3375

Chart G
No. 75 (-84 3375) actuator with **ELASTOMER** Diaphragm

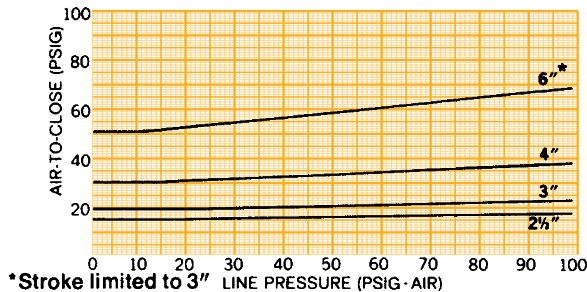
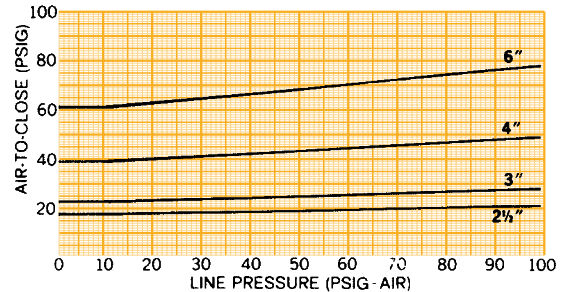

Chart H
No. 75 (-84 3375) actuator with **PTFE PLASTIC** Diaphragm



33101

Chart I
No. 101 (-84 33101) actuator with **ELASTOMER** Diaphragm

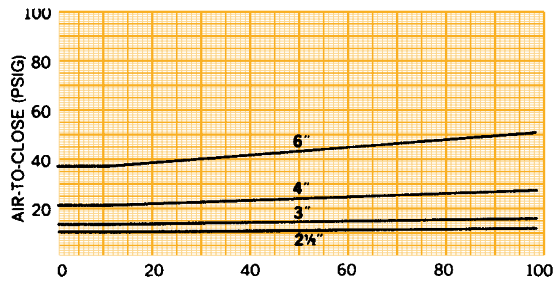
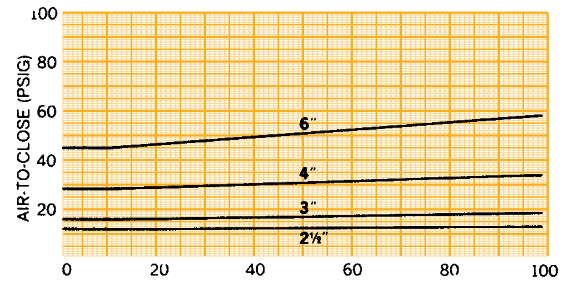

Chart J
No. 101 (-84 33101) actuator with **PTFE PLASTIC** Diaphragm



33130

Chart K
No. 130 (-84 33130) actuator with **ELASTOMER** Diaphragm

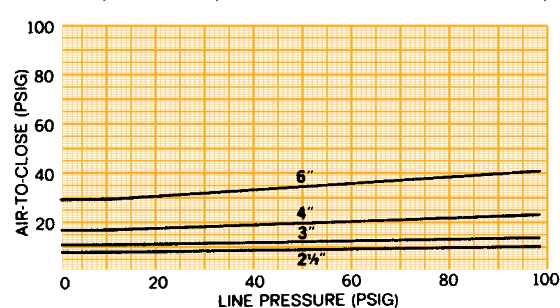
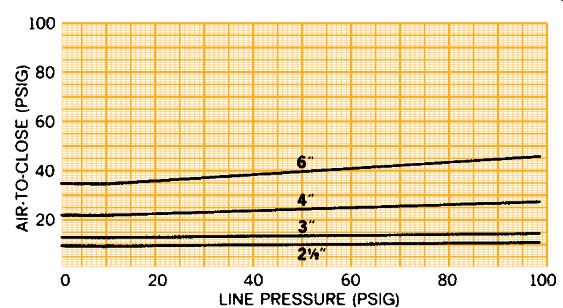

Chart L
No. 130 (-84 33130) actuator with **PTFE PLASTIC** Diaphragm



Advantage[®] Actuators for Weir Type Valves

Introduction

The operationally proven low profile Advantage[®] Actuator is now available for industrial weir style diaphragm valves. To meet the changing needs of our customers, we have combined the Advantage Actuator with the Dia-Flo[®] diaphragm valve. This new combination gives the valve a smaller installation envelope, the latest automation technologies, and proven long life.

Through the use of a new 316 stainless steel investment cast bonnet we are able to mount the Advantage Actuator to plastic lined, rubber lined, glass lined and unlined weir style industrial diaphragm valves.

Features

- Small dimensional envelope
- Corrosion resistant exterior
- Available on lined and unlined valves
- Rugged switch mounting on top of actuator
- Stainless steel and ductile iron bonnets
- Discrete and Network Protocol switch packages available

Benefits

- Allows for installation into tight spaces such as around the top of reactors
- Provides for longer life and better aesthetics in corrosive environments
- Allows for use on most common applications
- Provides a compact actuated package free from brackets and striker arms which could become damaged
- Provides for more robust mounting than plastic bonnets
- Provides the latest in communication technology



Figure 3-2556-TM-34-C7-A234

Advantage[®] Actuators for Weir Type Valves

Smaller Dimensional Envelope

Check the size differential for a typical fail close application.

- 2" Line Size
- 100% ΔP
- 90 psi Line Pressure
- 90 psi Air Pressure

46% Reduction in Height
35% Smaller in Diameter
51% Reduction in Weight



Weir Type Plastic Lined Valve with Advantage Actuator

Understanding Advantage Actuator Model Numbers

A = Advantage Actuator

Mode

- 1 Fail Open, Air-to-Close, Spring-to-Open
- 2 Fail Close, Air-to-Open, Spring-to-Close
- 3 Double Acting, Air-to-Close, Air-to-Open

Actuator Series Size

- 05** (05, 06)
- 08** (08, 09)
- 16** (15, 16, 17)
- 33** (32, 33, 34, 35)
- 47** (47, 48)

Examples

Model #A308=Double Acting Actuator Series 8

Model #A232=Fail Closed Actuator Series 33 with a 32 Spring Set

Note: Series size 05, 08 etc. equates to diaphragm effective area; Values in parentheses are specific spring combinations for fail closed actuators.

Air Requirements for Weir Type Valves with Advantage[®] Actuators

Use the charts on this page for 100% pressure drop for these Figure Numbers:

2401	2437R	2414	2444
2402	2441	2416	2447
2412	2456	2417	2451
2431	2464	2424	2463
2432	2465	2427	2484
2433R	2466	2436	2486
2433A	AND*	2442	2487
2435R	2406	2443	

For columns listing air-to-open, figure listed is air required to open at 0 psi line pressure. Less air will be needed when line pressure is available to assist opening the valve.

Select correct chart by finding body figure number in left margin and check for correct pressure drop condition and diaphragm condition.

*1/2-2" Sizes Only

100% ΔP Elastomer

Reverse Acting (Spring Close / Air Open)				Double Acting (Air Close / Air Open)				Direct Acting (Air Close / Spring Open)			
Valve Size	Actuator Size	Max Line	Air to Open'	Valve Size	Actuator Size	Max Line	Air to Close	Valve Size	Actuator Size	Max Line	Air to Close
0.5	A205	110	50	0.5	A305	150	42	0.5	A105	150	58
0.5	A206	150	90								
0.5	A208	150	50	0.75	A308	150	38	0.75	A108	125	60
0.75	A209	150	90								
1	A208	150	60	1	A308	150	44	1	A108	150	55
1.5	A216	100	50	1.5	A316	150	40	1.5	A116	150	52
1.5	A217	150	90								
1.5	A232	150	47								
2	A216	70	60	2	A316	150	50	2	A116	100	60
2	A217	150	90								
2	A232	150	47								
3	A233	95	62	3	A333	150	57	3	A133	76	60
3	A234	150	85								
3	A247	150	60								
3	A233	130	60								
3	A233	150	68								
4	A233	70	62	4	A333	150	68	4	A133	100	80
4	A234	110	85								
4	A247	119	60								
4	A233	125	90								
4	A248	150	82								
4	A233	150	49	4	A347	150	49	4	A147	129	60
4	A234	150	82								
4	A247	150	65								

100% ΔP PTFE

Reverse Acting (Spring Close / Air Open)				Double Acting (Air Close / Air Open)				Direct Acting (Air Close / Spring Open)			
Valve Size	Actuator Size	Max Line	Air to Open'	Valve Size	Actuator Size	Max Line	Air to Close	Valve Size	Actuator Size	Max Line	Air to Close
0.5	A205	50	65	0.5	A305	150	48	0.5	A105	100	60
0.5	A206	150	90								
0.5	A208	150	50								
0.75	A208	140	60	0.75	A308	150	46	0.75	A108	60	60
0.75	A209	150	90								
1	A208	100	70	1	A308	125	60	1	A108	60	60
1	A209	150	90	1	A308	150	65	1	A108	60	60
1	A215	150	52	1	A316	150	45	1	A108	150	80
1.5	A216	125	50	1.5	A316	150	55	1.5	A116	80	60
1.5	A217	150	90								
1.5	A232	150	47								
2	A216	60	60	2	A316	100	60	2	A116	70	60
2	A217	150	90								
2	A232	150	47								
2	A216	60	60	2	A316	150	68	2	A116	150	82
2	A217	150	90								
2	A232	150	47								
3	A233	50	62	3	A333	108	60	3	A133	86	80
3	A234	105	85								
3	A247	133	62								
3	A248	150	82	3	A347	150	45	3	A147	131	60
4	A233	30	62								
4	A234	60	85								
4	A233	69	60	4	A333	119	80	4	A133	26	80
4	A234	119	80								
4	A233	150	90								
4	A247	70	62	4	A347	118	60	4	A147	73	60
4	A233	125	90								
4	A248	150	82								
4	A233	150	68	4	A347	150	68	4	A147	131	80
4	A234	150	82								
4	A247	150	83								

Air Requirements for Weir Type Valves with Advantage[®] Actuators

Use the charts on this page for 100% pressure drop for these Figure Numbers:

2403	2501	2538	2552	AND*
2405	2511	2540A	2553	2436
2407	2516	2544	2555	2444
2408	2521	2545	2556	2447
2410	2522	2546	2556A	2484
2470	2523	2548	2558	2486
2472	2529	2550	2559	2487
2474	2536	2551	2575	

For columns listing air-to-open, figure listed is air required to open at 0 psi line pressure. Less air will be needed when line pressure is available to assist opening the valve.

Select correct chart by finding body figure number in left margin and check for correct pressure drop condition and diaphragm condition.

*Sizes 3" and 4" Only

100% ΔP Elastomer

Reverse Acting (Spring Close / Air Open)				Double Acting (Air Close / Air Open)				Direct Acting (Air Close / Spring Open)			
Valve Size	Actuator Size	Max Line	Air to Open ¹	Valve Size	Actuator Size	Max Line	Air to Close	Valve Size	Actuator Size	Max Line	Air to Close
0.5	A205	50	50	0.5	A305	140	60	0.5	A105	55	60
0.5	A206	130	90	0.5	A305	150	64	0.5	A105	150	87
0.5	A208	130	50	0.5	A308	150	45	0.5	A108	125	60
0.5	A209	150	70	0.5	A308	150	45	0.5	A108	150	65
0.75	A208	90	45	0.75	A308	150	56	0.75	A108	70	60
0.75	A209	150	90	0.75	A308	150	56	0.75	A108	150	77
1	A208	110	60	1	A308	150	47	1	A108	140	60
1	A209	150	90	1	A308	150	47	1	A108	150	62
1	A215	150	52					1	A108	150	62
1.5	A216	90	50					1.5	A116	110	60
1.5	A217	150	90	1.5	A316	150	52	1.5	A116	150	72
1.5	A232	150	47					1.5	A133	150	32
2	A216	50	60	2	A316	120	60	2	A116	60	60
2	A217	140	90	2	A316	150	69	2	A116	150	87
2	A232	150	47	2	A333	150	19	2	A133	150	41
3	A233	70	62					3	A133	52	60
3	A234	150	85					3	A133	131	80
3	A247	150	60	3	A333	150	57	3	A133	150	86
3	A247	150	60					3	A147	116	60
3	A247	150	60					3	A147	150	71
4	A233	60	62	4	A333	115	60	4	A133	45	60
4	A234	90	85	4	A333	115	60	4	A133	93	80
4	A247	100	60	4	A333	150	70	4	A133	120	90
4	A247	100	60	4	A333	150	70	4	A147	91	60
4	A248	145	82	4	A347	150	56	4	A147	143	80
4	A248	145	82	4	A347	150	56	4	A147	150	83

100% ΔP PTFE

Reverse Acting (Spring Close / Air Open)				Double Acting (Air Close / Air Open)				Direct Acting (Air Close / Spring Open)			
Valve Size	Actuator Size	Max Line	Air to Open ¹	Valve Size	Actuator Size	Max Line	Air to Close	Valve Size	Actuator Size	Max Line	Air to Close
0.5	A209	70	70	0.5	A305	80	90	0.5	A108	125	89
0.5	A209	70	70	0.5	A308	60	60	0.5	A108	125	89
0.75	A209	30	90	0.75	A308	20	60	0.75	A108	40	87
0.75	A209	30	90	0.75	A308	125	87	0.75	A108	40	87
1	A215	120	52	1	A308	30	60	1	A108	60	86
1	A217	150	74	1	A308	125	86	1	A108	60	86
1	A217	150	74	1	A316	150	52				
1.5	A217	100	90	1.5	A316	90	60	1.5	A116	35	60
1.5	A217	100	90	1.5	A316	150	79	1.5	A116	125	90
1.5	A232	150	47	1.5	A333	150	23	1.5	A133	150	41
2	A217	90	90	2	A316	80	60	2	A116	30	60
2	A232	150	47	2	A316	150	85	2	A116	100	86
2	A232	150	47	2	A333	150	24	2	A133	150	46
3	A233	40	62	3	A333	87	60	3	A133	20	65
3	A234	80	85	3	A333	137	80	3	A133	66	80
3	A247	80	62	3	A333	150	87	3	A133	86	86
3	A248	150	82	3	A347	127	60	3	A147	100	60
3	A248	150	82	3	A347	150	69	3	A147	150	76
4	A234	35	85	4	A333	48	60	4	A133	35	80
4	A234	35	85	4	A333	89	80	4	A133	50	90
4	A247	50	62	4	A333	105	90	4	A147	44	60
4	A247	50	62	4	A347	82	60	4	A147	86	80
4	A248	100	90	4	A347	130	80	4	A147	100	90
4	A248	100	90	4	A347	150	84	4	A147	100	90

Air Requirements for Weir Type Valves with Advantage[®] Actuators

Use the charts on this page for 0% pressure drop for these Figure Numbers:

2401	2437R	2414	2444
2402	2441	2416	2447
2412	2456	2417	2451
2431	2464	2424	2463
2432	2465	2427	2484
2433R	2466	2436	2486
2433A	AND*	2442	2487
2435R	2406	2443	

For columns listing air-to-open, figure listed is air required to open at 0 psi line pressure. Less air will be needed when line pressure is available to assist opening the valve.

Select correct chart by finding body figure number in left margin and check for correct pressure drop condition and diaphragm condition.

*1/2–2" Sizes Only

0% ΔP Elastomer

Reverse Acting (Spring Close / Air Open)				Double Acting (Air Close / Air Open)				Direct Acting (Air Close / Spring Open)			
Valve Size	Actuator Size	Max Line	Air to Open ¹	Valve Size	Actuator Size	Max Line	Air to Close	Valve Size	Actuator Size	Max Line	Air to Close
0.5	A205	90	50					0.5	A105	80	60
0.5	A206	150	90	0.5	A305	150	60	0.5	A105	150	75
0.5	A208	150	50					0.5	A108	150	60
0.75	A208	60	45					0.75	A108	40	60
0.75	A209	120	90	0.75	A308	150	60	0.75	A108	125	85
1	A208	80	60	1	A308	135	60	1	A108	80	60
1	A209	130	90	1	A308	150	65				
1	A215	150	52	1	A316	150	40	1	A108	150	85
1.5	A216	65	50					1.5	A116	125	60
1.5	A217	130	90	1.5	A316	150	50	1.5	A116	150	65
1.5	A232	150	47					1.5	A133	150	33
2	A216	30	60	2	A316	100	60	2	A116	60	60
2	A217	75	90	2	A316	150	80	2	A116	125	80
2	A232	150	47	2	A333	150	25	2	A133	150	44
3	A233	60	62	3	A333	105	60	3	A133	45	60
3	A234	92	85	3	A333	150	80	3	A133	85	80
3	A247	92	60	3	A347	147	60	3	A133	100	90
3	A248	150	76	3	A347	150	61	3	A147	88	60
				3	A147	142	80				
4	A233	35	62	4	A333	67	60	4	A133	27	60
4	A234	50	85	4	A333	90	80	4	A133	53	80
				4	A333	100	84	4	A133	80	90
4	A247	59	60	4	A347	80	60	4	A147	68	60
				4	A347	133	80	4	A147	102	80
4	A248	83	82	4	A347	150	88	4	A147	125	90

0% ΔP PTFE

Reverse Acting (Spring Close / Air Open)				Double Acting (Air Close / Air Open)				Direct Acting (Air Close / Spring Open)			
Valve Size	Actuator Size	Max Line	Air to Open ¹	Valve Size	Actuator Size	Max Line	Air to Close	Valve Size	Actuator Size	Max Line	Air to Close
0.5	A205	25	65	0.5	A305	130	60	0.5	A105	125	86
0.5	A206	150	90					0.5	A305	150	62
0.5	A208	100	50					0.5	A108	150	70
0.5	A209	150	70					0.5	A308	150	45
0.75	A208	70	60								
0.75	A209	80	90	0.75	A308	150	60	0.75	A108	150	85
1	A208	35	70	1	A308	100	60	1	A108	40	60
1	A209	80	90	1	A308	150	80				
1	A215	120	52					1	A108	100	80
1	A217	150	74	1	A316	150	57				
1.5	A216	70	50	1.5	A316	150	62	1.5	A116	60	60
1.5	A217	125	90	1.5	A333	150	13	1.5	A116	150	76
1.5	A232	150	47					1.5	A133	150	37
2	A216	45	60	2	A316	60	60	2	A116	40	60
2	A217	70	90	2	A316	100	80	2	A116	100	90
2	A232	150	47	2	A333	150	37	2	A133	125	60
3	A233	20	62	3	A333	64	60	3	A133	20	60
3	A234	45	85	3	A333	104	80	3	A133	44	80
				3	A333	125	90	3	A133	60	88
3	A247	68	62	3	A347	105	60	3	A147	40	60
				3	A347	150	78	3	A147	70	80
3	A248	114	82	3	A347	150	78	3	A147	80	85
4	A233	15	62	4	A333	40	60	4	A133	20	80
4	A234	30	85	4	A333	67	80	4	A133	40	90
				4	A333	80	90	4	A147	33	60
4	A247	41	62	4	A347	63	60	4	A147	77	80
4	A248	70	90	4	A347	105	80	4	A147	100	90

Air Requirements for Weir Type Valves with Advantage[®] Actuators

Use the charts on this page for 100% pressure drop for these Figure Numbers:

2403	2501	2538	2552	AND*
2405	2511	2540A	2553	2436
2407	2516	2544	2555	2444
2408	2521	2545	2556	2447
2410	2522	2546	2556A	2484
2470	2523	2548	2558	2486
2472	2529	2550	2559	2487
2474	2536	2551	2575	

For columns listing air-to-open, figure listed is air required to open at 0 psi line pressure. Less air will be needed when line pressure is available to assist opening the valve.

Select correct chart by finding body figure number in left margin and check for correct pressure drop condition and diaphragm condition.

*Sizes 3" and 4" Only

0% ΔP Elastomer

Reverse Acting (Spring Close / Air Open)				Double Acting (Air Close / Air Open)				Direct Acting (Air Close / Spring Open)			
Valve Size	Actuator Size	Max Line	Air to Open'	Valve Size	Actuator Size	Max Line	Air to Close	Valve Size	Actuator Size	Max Line	Air to Close
0.5	A206	70	90	0.5	A305	75	60	0.5	A105	20	60
0.5	A208	70	50	0.5	A305	150	89	0.5	A105	80	85
0.5	A209	140	70	0.5	A308	140	60	0.5	A108	70	60
0.75	A208	60	45	0.5	A308	150	62	0.5	A108	150	81
0.75	A209	130	90	0.75	A308	115	60	0.75	A108	30	60
1	A208	65	60	0.75	A308	150	71	0.75	A108	125	90
1	A209	100	90	1	A308	115	60	1	A108	80	60
1	A215	150	52	1	A308	150	74	1	A108	125	81
1.5	A216	65	50	1	A316	150	43*	1	A108	125	81
1.5	A217	130	90	1.5	A316	120	60	1.5	A116	75	60
1.5	A232	150	47	1.5	A316	150	70	1.5	A116	150	90
2	A217	70	90	1.5	A333	150	20	1.5	A133	150	38
2	A232	120	47	2	A316	65	60	2	A116	30	60
2	A235	150	67	2	A316	100	81	2	A116	80	88
3	A233	50	62	2	A333	150	32	2	A133	150	53
3	A234	80	85	3	A333	90	60	3	A133	20	62
3	A247	80	60	3	A333	140	80	3	A133	68	80
3	A248	130	76	3	A333	150	84	3	A133	80	84
4	A233	25	62	3	A347	128	60	3	A147	62	60
4	A234	40	85	3	A347	150	67	3	A147	121	80
4	A247	50	60	3	A347	150	90	3	A147	150	90
4	A248	80	82	4	A333	63	60	4	A133	46	80
				4	A333	89	80	4	A133	63	90
				4	A333	110	90	4	A147	52	60
				4	A347	80	60	4	A147	102	80
				4	A347	133	80	4	A147	125	90
				4	A347	150	88	4	A147	125	90

0% ΔP PTFE

Reverse Acting (Spring Close / Air Open)				Double Acting (Air Close / Air Open)				Direct Acting (Air Close / Spring Open)			
Valve Size	Actuator Size	Max Line	Air to Open'	Valve Size	Actuator Size	Max Line	Air to Close	Valve Size	Actuator Size	Max Line	Air to Close
0.5	A209	40	70	0.5	A305	40	87	0.5	A108	60	86
0.75	NA	NA	NA	0.5	A308	40	60	0.75	A108	20	83
1	A215	70	52	0.75	A308	125	87	0.75	A308	15	60
1	A217	150	74	0.75	A308	80	84	0.75	A308	80	84
1.5	A217	90	90	1	A308	20	60	1	A108	40	87
1.5	A232	150	47	1	A308	80	89	1	A108	40	87
2	A217	60	90	1	A316	115	60	1	A108	40	87
2	A232	100	47	1	A316	150	68*	1	A108	40	87
2	A235	150	67	1.5	A316	80	60	1.5	A116	30	60
3	A234	30	85	1.5	A316	150	85	1.5	A116	100	85
3	A247	45	62	1.5	A333	150	25	1.5	A133	150	42
3	A248	85	82	2	A316	50	60	2	A116	60	86
4	A247	30	62	2	A316	80	79	2	A116	60	86
				2	A333	150	35	2	A133	150	57
				3	A333	50	60	3	A133	37	80
				3	A333	80	80	3	A133	40	81
				3	A347	72	60	3	A147	30	60
				3	A347	115	80	3	A147	58	80
				3	A347	150	90	3	A147	80	90
				4	A333	34	60	4	A133	25	80
				4	A333	56	80	4	A133	35	90
				4	A333	65	90	4	A147	31	60
				4	A347	50	60	4	A147	66	80
				4	A347	82	80	4	A147	82	90
				4	A347	100	90	4	A147	82	90

Weir Type Valves with Direct Loaded Bonnet Assemblies

Direct Loaded Bonnet

An economical approach to automatic on-off operation for weir-type valves. Ideal for multi-valve panel operation of batching systems, water and waste treatment systems. Furnished with or without pilot solenoid utilizing pneumatic or hydraulic operation.

Special bonnets and diaphragms are available for operation by direct injection of air into bonnet on valves up to 3". Valve opening is dependent on line pressure. Such units are used where less exacting valve performance is acceptable.

A minimum line pressure of 20 psig is required to utilize the direct loaded valve.

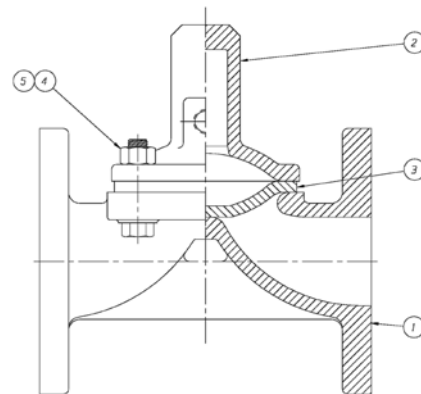
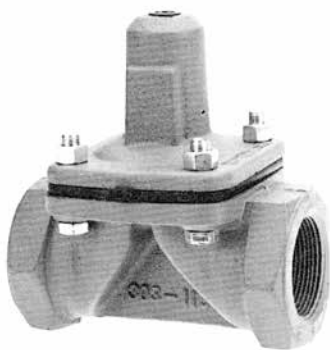

Air Requirements for "molded closed" diaphragm installation

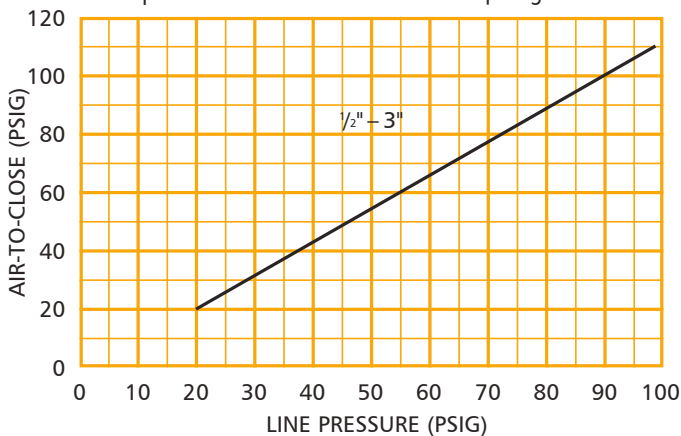

List of Parts			
Item	Description	Material	Qty
1	Body, Flanged	As Specified	1
2	Bonnet, Adapter	Cast Iron	1
3	Diaphragm	Elastomer, Gr DP	1
4	Bolt, Bonnet	Steel	4
5	Nut, Hex.	Steel	4

Other Available Actuator Options

Sliding Stem Bonnet Assembly

Dia-Flo® sliding stem bonnet assemblies are designed to accommodate almost every make of power operated topworks. Pneumatic, electro-hydraulic, electric and electronic actuators can all be easily adapted to both weir and straightway Dia-Flo® Diaphragm Valves. Designs incorporate simple mounting and accurate alignment between the actuator and valve stem.

Other than the standard close coupled design, ITT pneumatic actuators may be yoke mounted to suit your specifications and to accommodate a variety of actuator accessories. A complete range of instrumentation accessories are also available mounted and piped for easy installation.

Dia-Flo® valves can also be supplied with pneumatic actuators of other manufacturers or with electric actuators sized for optimum performance.



** Stem nut is provided only when actuator is furnished by ITT. If actuator is furnished by others please be certain to specify the exact actuator and model number for each order item.*

Actuators for Straightway Valves

Pneumatic actuation for Dia-Flo® straightway valves is the same high quality, rugged airmotor actuator used on weir type valves. Use charts on the following pages to select the correct Dia-Flo® actuator for your straightway valve application.

Note: Refer to actuator sizing information in the beginning of section 3 for operating instructions on using these charts.

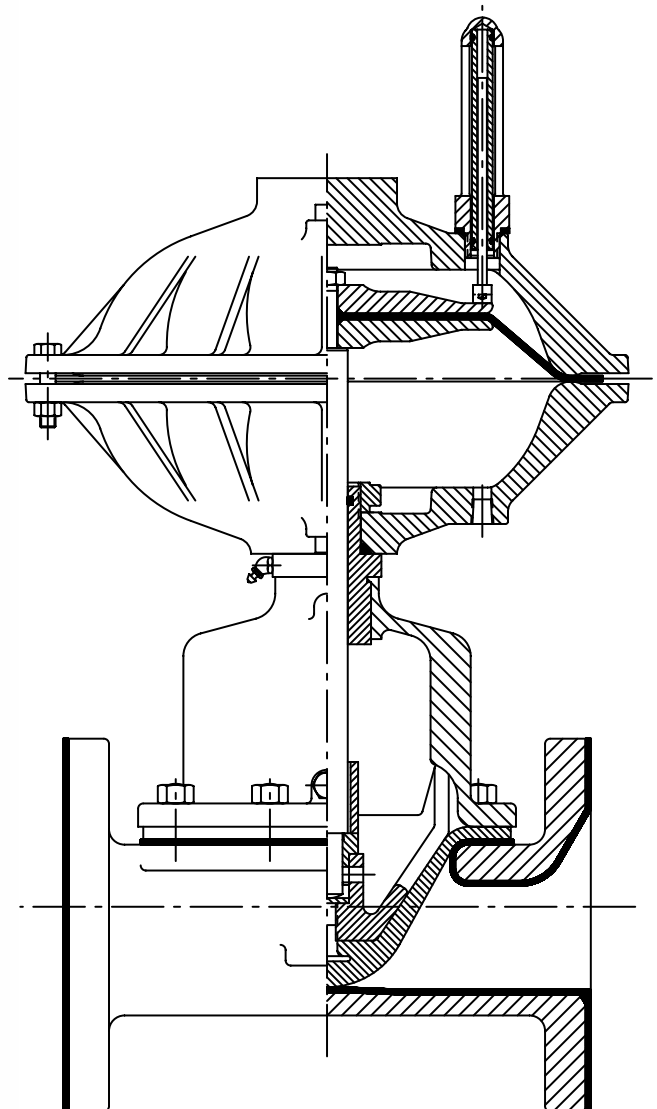

Air Requirements for Straightway Valves

3100 Series Fail Open Actuators 100% ΔP Air-to-Close, Spring-to-Open

3125

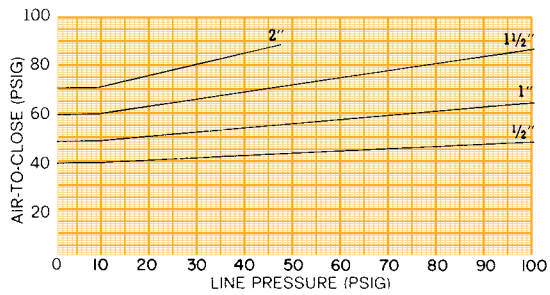

3150

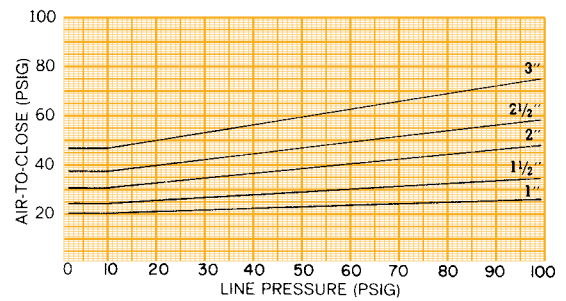

31101

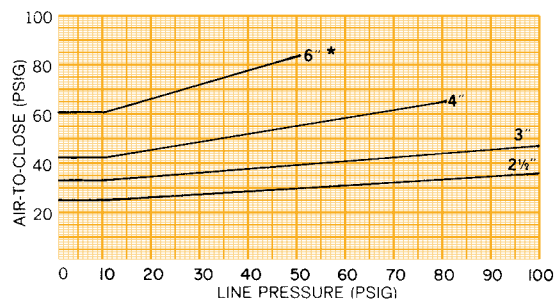

*Stroke limited to 3 1/8"

31130

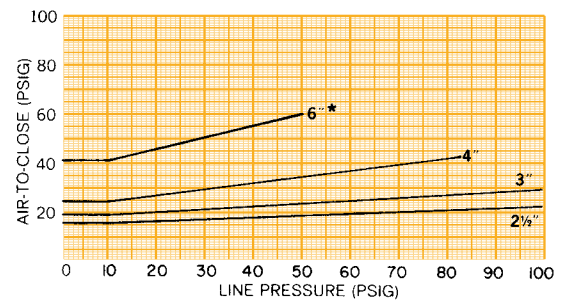

*Stroke limited to 3 1/2"

31250

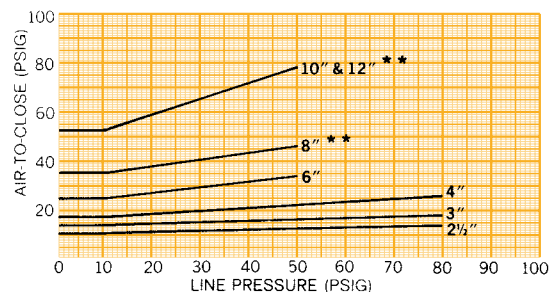

**Stroke limited to 4 5/8"

**3200 Series Fail Close Actuators
Air-to-Open, Spring-to-Close
100% ΔP Straightway**

Use chart to determine size and spring requirements.

Air Requirements for Straightway Valves

Actuator Size	Figure Number	Spring Number	Maximum Line Pressures (PSI) at 100% PD (Bubble Tight Shut Off) Straightway Valves										Air to Open Full Stroke at 0 PSI Line	
			1"	1 1/2"	2"	2 1/2"	3"	4"	6"	8"				
#25	3226	101	40											55
	3228	102A												30
	3227	101 & 102A	100	50										85
#50	3251	101												27
	3252	101 & 102A	180											44
#50L	3254	96	100	100	35									41
	3253	97	50											24
	3255	96 & 97	100	100	100	70	20	20						61
#75	3273	98				67	26	26						34
	3277	97 & 98				100	71	71	16					47
	3278	96 & 98				100	100	100	34					63
	3279	96, 97 & 98				100	100	100	54					76
#101	32102	96				13								20
	32103	98				67	26	26						28
	32104	96 & 97				100	31	31						30
	32105	96 & 98				100	100	100	34					48
	32106	97 & 98				100	71	71	16					38
#130	32107	96, 97 & 98				100	100	100	54					58
	32108	130				100	100	100	85	17*				85
	32132	96				13								16
	32133	98				67	26	26						23
	32134	96 & 97				100	31	31						24
#250	32135	96 & 98				100	100	100	34					39
	32136	97 & 98				100	71	71	16					32
	32137	96, 97 & 98				100	100	100	54					48
	32138	130				100	100	100	85	17†				67
#250	32252	129				100	100	100	85	22				30
	32253	130				100	100	100	85	10				32
	32251	129 & 130				100	100	100	85	50				62

*Stroke Limited to 3/8"

†Stroke Limited to 3/4"

*Stroke Limited to 4/8"

Air Requirements for Straightway Valves

3300 Series Double Acting Actuators 100% ΔP

Air-to-Open, Air-to-Close

Actuators are designed to operate at air pressures up to 85 psi on diaphragm actuators. The difference in pressure between the upper and lower chambers should not exceed 85psi.

If ordering an actuator with positioner, an air cushion regulator will be added to provide 10 psi in the lower chamber. Therefore, add 10 psi to the Air-to-Close value for minimum air required.

3325

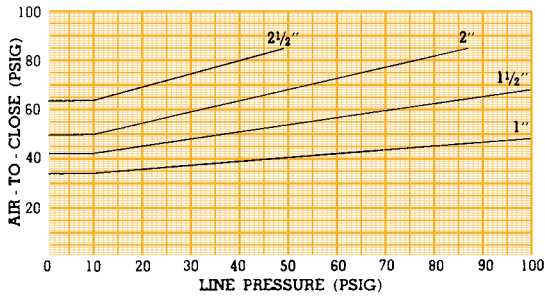

3350

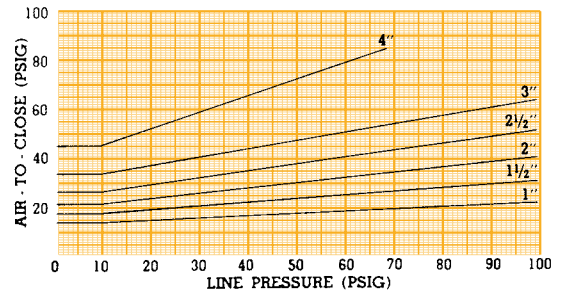

3375

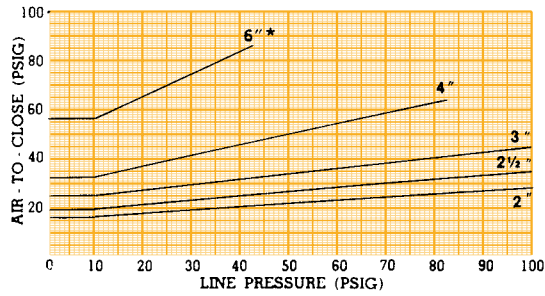

*Stroke limited to 3"

33101

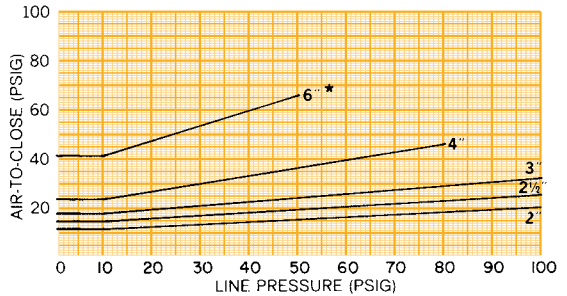

*Stroke limited to 3 1/2"

33130

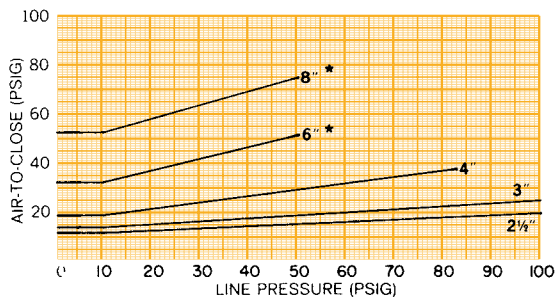

*Stroke limited to 3 1/2"

33250

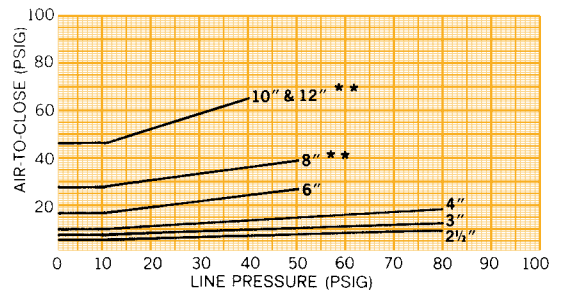

**Stroke limited to 4 5/8"

Section 4

Diaphragm Valve Accessories



Contained in this section:

Accessories for:

- Manual Valves
- Actuated Valves

Accessories for Manually Operated Valves

Manual Valve Bonnet Assembly Selections

O-Ring Sealed Bonnet

Provides a secondary seal which retains fluids or gases within the valve bonnet in the event of diaphragm failure. A standard sealed bonnet is recommended for hazardous materials which will not damage bonnet shell, bushing or spindle (stem). On corrosive fluids or gases, either non-sealed bonnets or in cases where the fluids or gases must be contained, more corrosion-resistant materials should be utilized. All sealed bonnets are provided with v-notch vent plugs to provide a safe and easy method of checking diaphragm integrity.

If a sealed bonnet is used and the bonnet assembly cannot handle the line media for a prolonged period of time, contact ITT for recommendations.

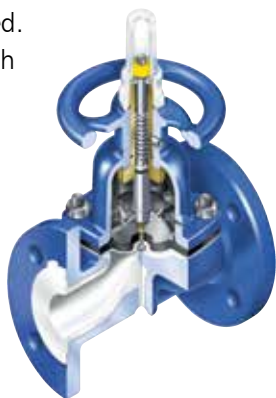

Handwheel Locking Device

Secures valve in position so that it may not be operated unless unlocked and disengaged.



Chain Wheel Operated

Uses standard sprocket rim, guide and chain. Available 1/2"-12", weir or straightway.



Extended Stem

Available in all sizes. Not available with solid plastic bodies.



Direct Loaded Bonnet

An economical approach to automatic on-off operation. Ideal for multi-valve panel operation of batching systems, water and waste treatment systems. Furnished with or without pilot solenoid utilizing pneumatic or hydraulic operation. Available in sizes 1/2"-3" for pressures up to 100 psi. Suitable for all standard weir body materials. See Actuator section for details.



Other Available Options

Bonnet Assemblies of:

- Stainless Steel
- Ductile Iron
- Bronze
- PAS (Polyarylsulfone) Plastic

Gear Boxes

Especially suitable for large size valves with high line pressures this accessory reduces the amount of force required to manually operate the valve.

Vacuum Preparation

Dia-Flo® diaphragm valves are capable of bubble-tight shut-off down to 0.1 micron. Elastomer or PTFE diaphragms may be used. The standard weir valve design with elastomer diaphragm is capable of in-leakage of less than 1×10^{-6} atmcc/sec, and on special order it can be furnished with a substantially lower in-leak rate.

Accessories for Pneumatically Operated Valves

Positioners

For stable and accurate positioning of the actuator stem for precise control of flow through the valve.



Conoflow Positioner



Pneumatic Moore Positioner with Gauges



Digital positioner with Fieldbus Communications Protocol

Limit Switches

For determining valve position remotely. Choose from a wide range of mechanical or proximity options including models suitable for hazardous locations.



Honeywell Micro-Switch BAF1-2RN



Proximity Westlock Switch Mod 3



SO 2.0 Switch Pack



Value Switch Pack (VSP) Mechanical and Proximity Switch

Accessories for Pneumatically Operated Valves

Solenoids

Used to control valve activation, solenoid valves are available in 3-way normally closed or open models as well as 4-way for double-acting actuators.



Asco Solenoid Valve

Filter Regulators

Used to provide clean, regulated air pressure to instruments, controls and actuators.



Conoflow Filter Regulator with Gauge

Speed Control Valves

To control the rate at which automated pneumatic valves operate.



Schraeder Speed Control Valve Option

Transducers

Accept a variety of electrical input signals and convert them to proportional output signals of typically 3–15 psi.



Conoflow Transducer

Accessories for Pneumatically Operated Valves



PI POSITION INDICATOR

Metal rod in a plastic tube indicates whether the valve is open or closed. Furnished as a standard on all valves equipped with positioners. Position indicators can be furnished for field installation. Available on all Dia-Flo® air motors.

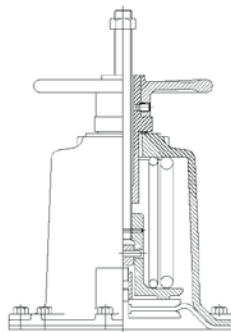

HWO HANDWHEEL OPENING DEVICE

An emergency opening device for fail close valves that includes travel stop. This option is available on all fail close actuators.



AO ADJUSTABLE OPENING STOP

The external threaded bolt can be adjusted to limit the opening of the valve. In an emergency the valve can also be closed using this device. Available on all #25 and larger actuators.

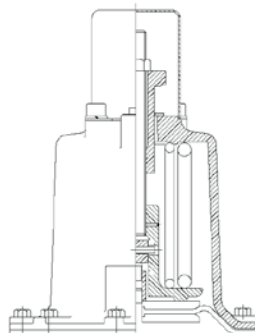

WO WRENCH OPENING DEVICE

Similar to the handwheel opening device except a wrench replaces the handwheel. Includes travel stop. This option is available on all fail close actuators except #250.

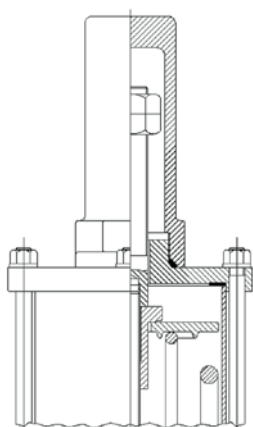

ATS ADJUSTABLE TRAVEL STOP

Field or factory adjustable closing travel stop will prevent over closure of the valve due to the use of excessive air pressure. Adjustable travel stops are standard on all #25 and larger failclose actuators. It is optional for #12 fail close actuators as well as for all failopen and double acting actuators.

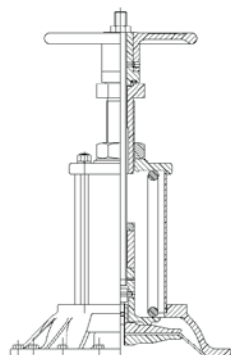

TOHO ADJUSTABLE OPENING STOP AND HANDWHEEL OPENING DEVICE

A combination device which includes an opening stop, travel stop and a hand wheel to manually open the valve, if necessary. Available only on fail close actuators. This option available on all fail close actuators except #250.

Accessories for Dia-Flo[®] Pneumatic Actuators

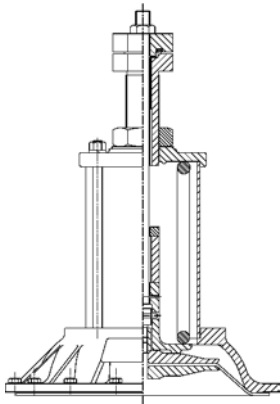

TOWO ADJUSTABLE OPENING STOP AND WRENCH OPENING DEVICE

Similar to the V/TOHO except awrench is utilized to open the valve in lieu of a handwheel. Available only on fail close actuators #12-75.

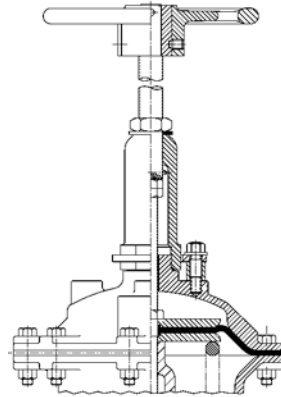

THC ADJUSTABLE OPENING, ADJUSTABLE TRAVEL STOP AND HANDWHEEL CLOSING DEVICE

A combination device which includes an opening stop, closing stop and handwheel to manually close the valve. Available on fail open and double acting actuators #25 and larger



HWC HANDWHEEL CLOSING DEVICE

This accessory will limit the opening of the valve and can be closed manually with the handwheel. Available with fail open and double acting actuators #25 and larger.



TOHC ADJUSTABLE OPENING, ADJUSTABLE TRAVEL STOP AND HANDWHEEL CLOSING DEVICE

Special device only for #12 fail open and double acting actuator. This accessory performs the same function as the V/THC. (Can be used instead of AO, HWC, TO or THC for #12 actuators.)

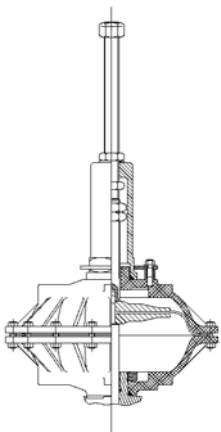

TO ADJUSTABLE OPENING STOP AND ADJUSTABLE TRAVEL STOP

A Combination device which includes both an opening stop and a closing stop. Available on fail open and double acting actuators #25 and larger.

Section 5

Diaphragm Valve Technical Data



Contained in this section:

- Pressure / Temperature Charts
- Valve and Actuator Weights
- Materials Specifications and Industry Standards
- Valve Drawings / Dimensions
- Bill of materials
- Flow Coefficients and Computations
- Service Guide

Pressure / Temperature Recommendations

Operating Pressures for Handwheel Operated Valves

Weir Valves

Size (in)	Max. Pressure (psig) at 120° F	Max Pressure (kpag)
1/2, 3/4, 1	200	1379
1 1/4, 1 1/2, 2	175	1207
2 1/2	150	1034
3	150	1034
4	150	1034
6	125	862
8	100	689
10, 12	65	448

Handwheel Operated Valves

The handwheel operated valves are designed to withstand the maximum differential pressure, as represented by the straight line in the P / T curve and decays linearly with increasing temperature above 120° F. Actual temperature limitations could be dictated by the service media being handled.

Automated Valves

Industry practice is to size the valve actuator to close against the maximum shut-off pressure that the valve will encounter while in service. Therefore, the maximum pressure differential will be dictated by the size of the actuator selected. Also, the seat test pressure to be performed during production testing will correspond to the actuator's maximum differential pressure. The maximum differential pressure can be found in the manufacturers product catalog.

Straightway and Weir Valve Pressure Temperature Recommendations

- To determine the maximum recommended operating pressure, enter the graph at the point corresponding to the maximum operating temperature of the process.
- The intersection of this temperature line with the respective valve size curve determines the maximum recommended operating pressure, read at the left side of the graph.
- The maximum recommended operating temperature can be determined by knowing the maximum operating pressure and reversing the above procedure.
- Operating pressure and temperature combinations above the respective valve size curves should be avoided to maximize diaphragm service life.
- Maximum temperature limitations of various diaphragm materials are also indicated by arrows under each diaphragm material.

Pressure / Temperature Recommendations

All Weir Valves Except Solid Plastic

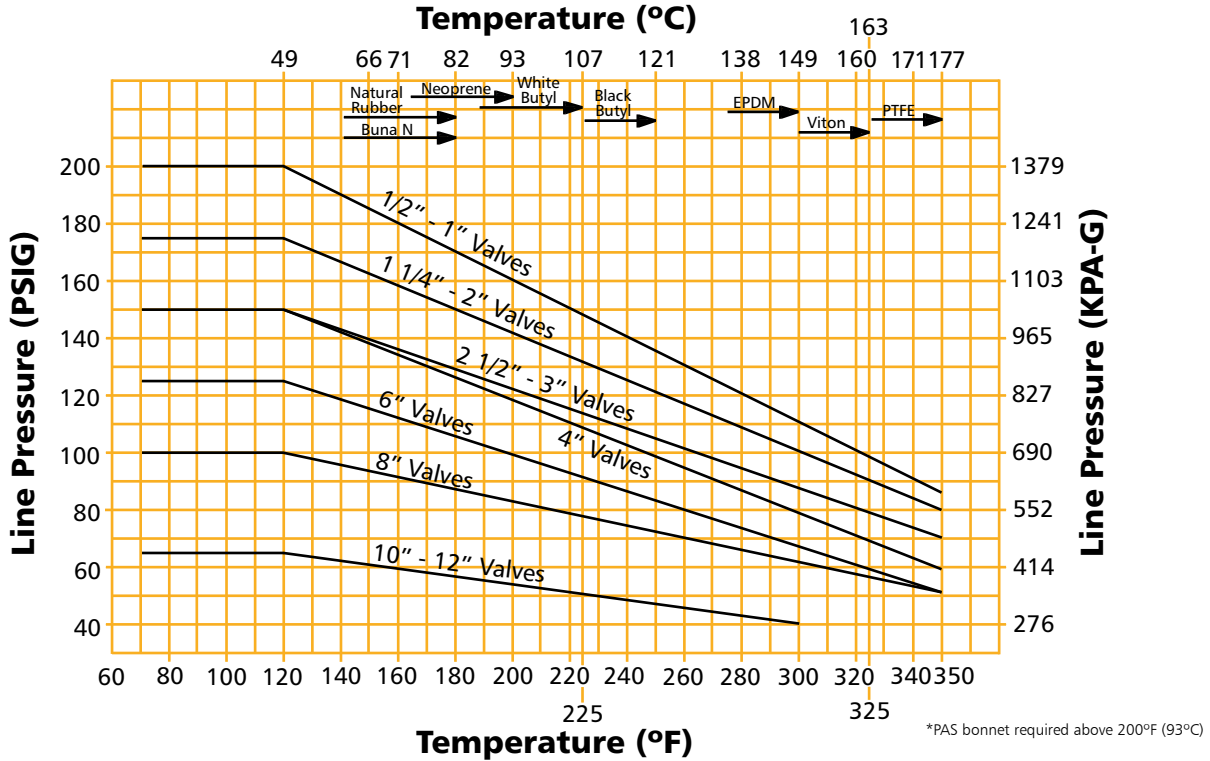

Solid Plastic Weir Valves

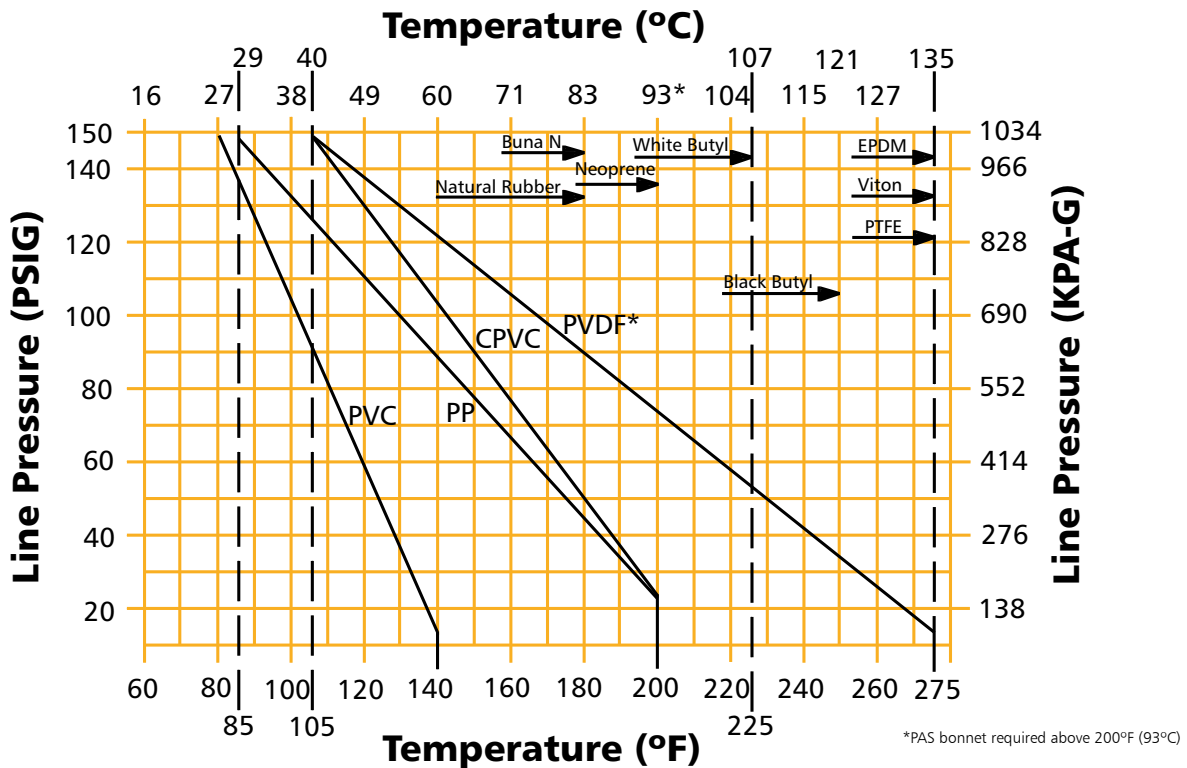

Pressure / Temperature Recommendations

Straightway Valves

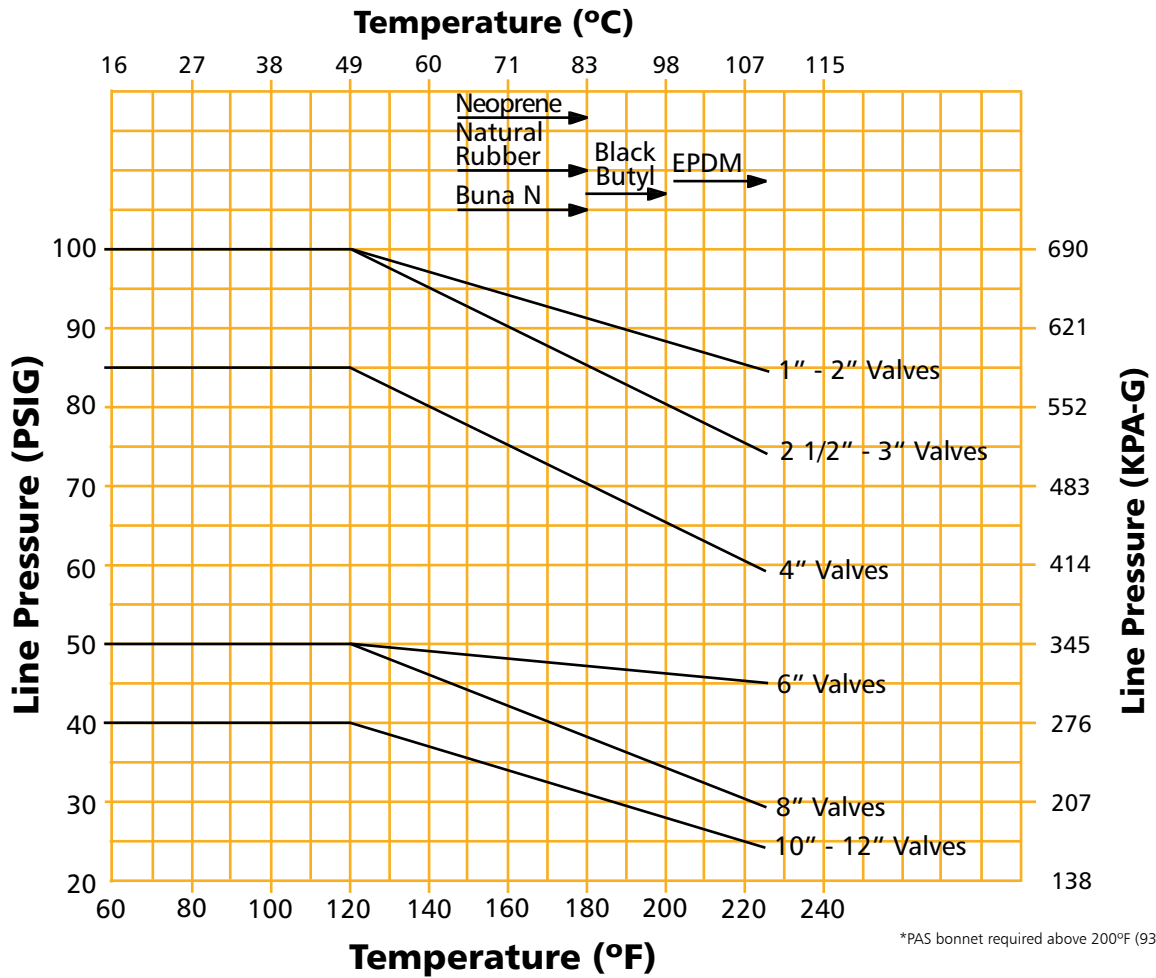

Weir-type Valves for Vacuum Service

Vacuum Service

The standard Dia-Flo® diaphragm weir valve is ideally suited for vacuum service when shipped from the factory. Dependable performance and good service life from atmospheric pressure down to 0.1 microns make this an excellent valve for industrial processing. The diaphragm presents a smooth face with no hidden voids on either side of the valve, whether open, closed or throttling, and is bidirectional. (Be sure to specify when vacuum is involved.)

Note: Straightway valves are not recommended for vacuum service.

Elastomer diaphragms for Vacuum Service

The non-porous diaphragm has a low vapor pressure high resistance to outgassing. The design inherently eliminates any possibility of stem leakage.

The standard weir valve design with elastomer diaphragm is capable of in-leakage of less than 1×10^{-6} atm-cc/sec, and on special order it can be furnished with a substantially lower in-leak rate.

The standard temperature recommendations shown on the Standard Pressure / Temperature Chart for Weir Type Valves should be followed when an elastomer diaphragm is used.

PTFE Diaphragms for Vacuum Service

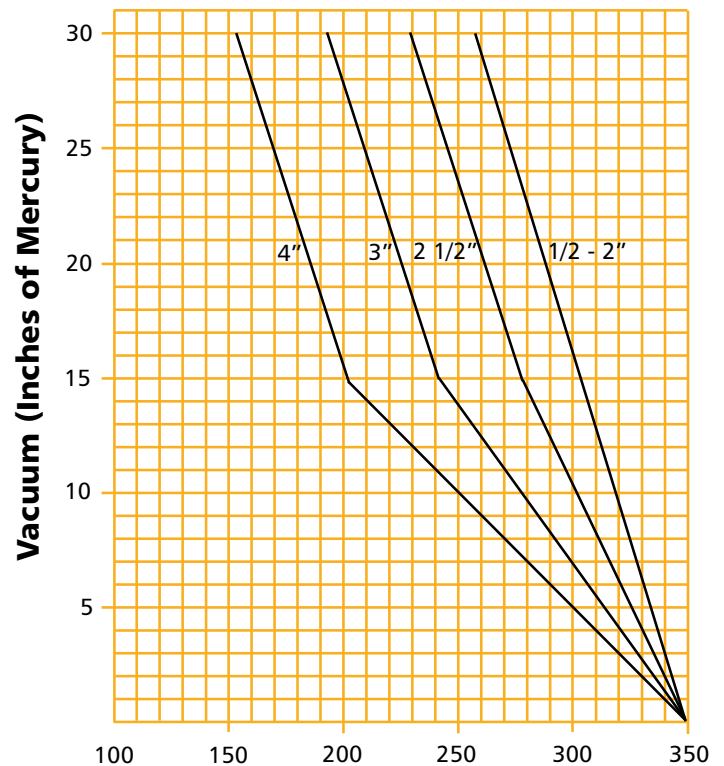

Notes:

1. Service conditions falling to the right of these lines will require bonnet evacuation.
2. PTFE diaphragms 6" size and larger will not withstand full vacuum at any temperature unless bonnets are evacuated.
3. With evacuated bonnets any size PTFE diaphragms can be used up to 350° F.

Stem Travel (Valve Stroke) and Turns

Stem Travel (Stroke) and Turns, for Conventional Weir Type Valves

Valve size (in) (DN)	1/2 15	3/4** 20	1 25	1 1/4 32	1 1/2 40	2 50	2 1/2 65	3 80	4 100	6 150	8 200	10 250	12 300
Stem travel (in)* (mm)	1/4 6.4	3/8 9.5	1/2 12.7	13/16 20.6	13/16 20.6	1 1/8 28.6	1 3/8 34.9	1 5/8 41.3	2 1/8 54.0	3 1/8 79.4	4 5/8 117.5	5 5/8 142.9	6 1/2 165.1
Turns*	2	3	4	4 7/8	4 7/8	6 3/4	6 7/8	8 1/8	10 5/8	15 5/8	15 3/8	19 11/16	22 3/4
Threads (per inch on stem) (per mm on stem)	8 .31	8 .31	8 .31	6 .24	6 .24	6 .24	5 .20	5 .20	5 .20	5 .20	3 1/2 .14	3 1/2 .14	3 1/2 .14

* Between open and closed positions

** Stroke for 3/4 flanged weir valve is 1/2" except solid plastic.

Stem Travel (Stroke) and Turns, for Conventional Straightway Type Valves

Valve Size (inches) (DN)	1 25	1 1/2 40	2 50	2 1/2 65	3 80	4 100	6 150	8 200	10 250	12 300
Stem Travel (Inches)* (mm)	15/16 23.8	1 1/4 31.8	1 7/8 47.6	2 50.1	2 3/16 58.7	2 13/16 71.4	4 1/4 108.0	6 1/4 158.8	7 1/2 190.5	7 1/2 190.5
Turns*	5 3/4	7 3/4	11 1/2	10 1/4	11 3/4	14 1/4	21 1/2	22 1/4	26 1/2	26 1/2

*Between open and closed positions

Dia-Flo® Actuator Stroke

Actuator Size	12	25	50	75	101	130	250
Stroke (in)	5/8	2	3	3	3 1/8	3 1/2	4 5/8
Stroke (mm)	15.9	50.8	76.2	76.2	79.4	88.9	117.5

Advantage Actuator Stroke

Actuator Size	5	8	16	33	47
Stroke (in)	1/4	1/2	1 1/8	1 5/8	1 5/8
Stroke (mm)	6.4	12.7	28.6	41.3	41.3

Weights, Manual Valves

Weir Valve Weights

All weights are approximate, given in pounds and are for manual valve assemblies.

Handwheel operated

Valve size (inches)	½	¾	1	1¼ & 1½	2	2½	3	4	6	8	10	12
---------------------	---	---	---	---------	---	----	---	---	---	---	----	----

Weir bodies: of metal

Screwed:	Iron; St. Steel	1½	3	4	9½	15	26	39	–	–	–	–	–
	Bronze	1¾	3¾	4¾	10¾	15	28	39	–	–	–	–	–
Flanged: (unlined)	Iron; St. Steel	3¾	5¾	6¾	14½	21	33	47	81	147	330	510	870
	Bronze	4½	6½	7¾	16¾	24	37	53	92	164	–	–	–
Buttweld:	Steel; St. Steel	2½	2½	4	11	13	23½	34	59	150	–	–	–

Weir bodies: solid plastic

Screwed	PVC, CPVC	0.9	1.3	2.0	5.0	7.0	–	–	–	–	–	–	–
Socket weld	PP	0.8	1.1	1.6	4.5	6.0	–	–	–	–	–	–	–
	PVDF	0.9	1.3	1.8	5.4	7.4	–	–	–	–	–	–	–
Spigot Weld	PVC, CPVC	0.8	1.2	1.8	4.7	6.4	–	–	–	–	–	–	–
	PP	0.7	1.0	1.6	4.2	5.7	–	–	–	–	–	–	–
	PVDF	0.8	1.2	1.8	4.7	6.5	–	–	–	–	–	–	–
Flanged	PVC, CPVC	1.2	1.7	2.5	5.7	8.0	–	18.20	29.00	–	–	–	–
	PP	2.0	2.6	3.7	6.8	10.1	–	20.00	31.00	–	–	–	–
	PVDF	2.1	2.8	3.8	7.5	11.2	–	22.70	35.50	–	–	–	–

Straightway Valve Weights (Approx. lbs Each)

Body type	1	1½	2	2½	3	4	6	8	10	12
Flanged	8	17	24	38	49	82	178	340	500	590

Weights, Actuators

Dia-Flo® Actuator Weights*

Double Acting Diaphragm Type (Including Adapter Bushing)

#3312	5½ lbs
#3325	13½ lbs
#3350	33½ lbs
#3375	42 lbs
#33101	71 lbs
#33130	88 lbs
#33250	140 lbs

Fail Close

(Including Adapter Bushing)

#3213-3216	5½ lbs
#3226-3228	32½ lbs
#3251, 52, 56	55 lbs
#3253-3255	73 lbs
#3274-3279	78 lbs
#32102-32109	186 lbs
#32108	176 lbs
Special Spring Combination	
#32131-32138	207 lbs
#32138	200 lbs
Special Spring Combination	
#32252-32253	270 lbs
#32251	405 lbs

Fail Open

(Including Adapter Bushing)

#3112	5 lbs
#3125	24½ lbs
#3150	42 lbs
#31101	135 lbs
#31130	145 lbs
#31250	220 lbs

Advantage® Actuator Weights*

#A305	1.03	#A205, A206	1.37	#A105	1.12
#A308	1.95	#A208, A209	2.62	#A108	2.06
#A316	4.90	#A215-A217	9.24	#A116	5.40
#A333	39.00	#A232-A235	58.00	#A133	42.30
#A347	44.00	#A247, A248	63.00	#A147	47.30

*Add to manual valve weights for approximate weight of complete actuated valve.

Actuator Internal dimensions

Dia-Flo									
Actuator Size	Actuator Stroke	Air Connection	Effective Diaphragm Area (Sq. in.)	Actuator Volume (cu. in.)					
				Bottom Chamber		Upper Chamber			
				Double & Reverse Acting		Double Acting		Direct Acting	
				Open	Closed*	Open	Closed*	Open	Closed*
12 - 16	½"	½"	11.5	13.25	6.8	6.1	12.5	6.1	12.5
25 - 28	2"	½"	22.5	90.3	21.7	13.4	85.1	13.4	85.1
50 - 56	3"	½"	50	321.0	63.4	43.8	329.0	364	622
75 - 79	3"	½"	75	374.7	128.1	80.9	422.0	-	-
101 - 109	3¾"	½"	100	528.0	174.0	144.0	498.0	579	933
130 - 138	3½"	½"	130	698.7	202.9	212.0	710.9	647	1146
250 - 253	4¾"	½"	250	1650.0	750.0	675.0	1760.0	1110	2195

Note: * Using stroke of largest valve for which actuator is suitable

Advantage

Actuator Series	Actuator Stroke	Air Connection	Effective Diaphragm Area (Sq. in.)	Actuator Volume (cu. in.)	
				Bottom Chamber Maximum	Upper Chamber Maximum
				05	½"
08	½"	½"	8	7.63	12.51
16	1½"	½"	16	38.75	71.00
47	1½"	½"	47	250.20	463.80

Material Specifications and Industry Standards

Bodies (Weir / Straightway)

- Cast Iron ASTM A-126 Class B
- Ductile Iron ASTM A-395 Grade 60-40-18
- Cast Steel ASTM A-216 Grade WCB
- 316 Stainless Steel ASTM A-351 Grade CF8M
- 316L Stainless Steel ASTM A-351 Grade CF3M
- Bronze ASTM B62 Alloy 836
- Alloy 20 ASTM A-351 Grade CN7M
- Hastelloy C ASTM A-494 Grade CW-6M
- Monel ASTM A-494 Grade M-35-1
- PVC & CPVC ASTM D1784
- PVDF ASTM D3222
- Polypropylene ASTM D4101
- And More

Bonnets (Weir / Straightway)

- Cast Iron ASTM A-126 Class B
- Ductile Iron ASTM A-395 Grade 60-40-18
- Stainless Steel ASTM A-351 Grade CF8 (Weir)
- Bronze ASTM B62 Alloy 836 (Weir)
- Polypropylene (Weir Only 1/2"-4")
- PAS (Weir Only 1/2"-4")

Dia-Flo® Diaphragm Valves are manufactured to the following industry standards (where applicable):

ANSI / ASME B1.20.1	Pipe Threads
ASME B16.5	Flanged Valves
ASME / ANSI B16.1	Cast Iron Flanged Fittings
ASME B16.11	Socketweld Fittings
ASME / ANSI B16.15	Bronze Threaded Fittings
ASME B16.24	Bronze Flanges
ASME / ANSI B16.42	Ductile Iron Flanges
ASME B16.34	Steel Valves*
ASME B16.4	Cast Iron Threaded Fittings
ASME B31.1	Power Piping*
ASME B31.3	Petro / Chem Piping
MSS SP-88	Diaphragm Valves (Design and Manufacture Standard Practice)
ASME B16.25	Buttweld Ends

**May require special construction and testing. Consult factory for details.*

In addition ITT has complete capabilities for CMTR (Certified Materials Test Reports) and NDE (Non-destructive Examinations) which include dye penetrant, x-ray, alloy analyzer, etc.

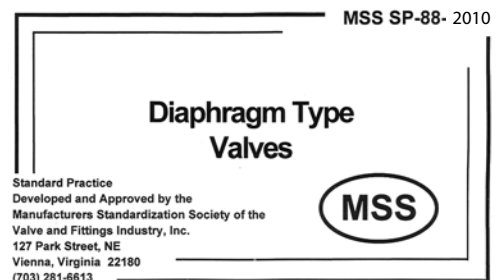

SEP Compliance for CE

Certification of SEP Compliance, Pressure Equipment Directive 97/23/EC

Dia-Flo® Weir Diaphragm Valve Application Restrictions per size:

Size	Max Pressure	Fluid Classification
½"-1"	13.8 bar / 200 psi	Grps 1 & 2 Liquids, Gases
1¼"-2"	12.1 bar / 175 psi	Grps 1 & 2 Liquids, Gases (not suitable for Unstable Gas use)
2½"-3"	10.3 bar / 150 psi	Grps 1 & 2 Liquids, Grp 2 Gases (not suitable for Grp 1 or Unstable Gas use)
4"	10.0 bar / 145 psi	Grps 1 & 2 Liquids, Grp 2 Gases (not suitable for Grp 1 or Unstable Gas use)
6"	8.6 bar / 125 psi	Grps 1 & 2 Liquids (not suitable for Grps 1 & 2 Gases or Unstable Gas use)
8"	6.9 bar / 100 psi	Grps 1 & 2 Liquids (not suitable for Grps 1 & 2 Gases or Unstable Gas use)
10"-12"	4.5 bar / 65 psi	Grps 1 & 2 Liquids (not suitable for Grps 1 & 2 Gases or Unstable Gas use)

Dia-Flo Straightway Diaphragm Valve Application Restrictions per size:

Size	Max Pressure	Fluid Classification
½"-1"	6.9 bar / 100 psi	Grps 1 & 2 Liquids, Gases
1½"-3"	6.9 bar / 100 psi	Grps 1 & 2 Liquids, Grp 2 Gases (not suitable for Grp 1 or Unstable Gas use)
4"	5.9 bar / 85 psi	Grps 1 & 2 Liquids, Grp 2 Gases (not suitable for Grp 1 or Unstable Gas use)
6"-8"	3.4 bar / 50 psi	Grps 1 & 2 Liquids, Grp 2 Gases (not suitable for Grp 1 or Unstable Gas use)
10"-12"	2.8 bar / 40 psi	Grps 1 & 2 Liquids, Grp 2 Gases (not suitable for Grp 1 or Unstable Gas use)

This Certification of SEP Compliance is expressly reserved for product that by definition the Pressure Equipment Directive may not be CE Marked. Product supplied with this certificate has been manufactured to sound engineering practices (as per PED Assessment Category "Sound Engineering Practices", Article 3 Paragraph 3).

Valve Linings and Solid Plastic Materials Specifications

The economies and conveniences resulting from the use of lined valves are well recognized. Engineers concerned with corrosion and abrasion resistant piping systems specify valves lined with plastic, rubber and glass. The unique design of the Dia-Flo® diaphragm valve lends itself admirably to this concept.

Plastic linings do not bond to the metal castings. To provide a mechanical bond while insuring a full thick lining, the end flanges, the bonnet flange and the entire casting interior is recessed. In addition, a unique Line-Lok feature in the weir area, which locks the plastic lining to the casting thus preventing movement, collapse or flexural stresses, is incorporated.

Below is a listing of the standard lining materials available with a brief description of each material.

PFA

PFA (perfluoroalkoxy) is especially useful to designers and end users who require a thermoplastic with excellent chemical stability, electrical properties and mechanical use in low and high temperature environments. PFA lined valves are available in sizes 1/2"-6" sizes for temperatures up to 350° F.

ETFE

ETFE is a tough modified copolymer of ethylene and tetrafluoroethylene (TFE). It offers outstanding resistance to chemicals at high temperatures and is especially resistant to solvents when compared to other fluoropolymers. The resin is unaffected by strong and weak acids, gases and solvents and below 392° F (200° C) has no known solvent. Cast Iron, ductile iron or cast steel flanged end bodies lined with ETFE (3/16" thick) (4.76 mm) are available in weir valve sizes 3/4" through 8" and cast iron lined straightway valve sizes 1" through 8".

Continuous use temperature is 300° F (149° C).
Color coded white.

Polypropylene (PP)

Polypropylene is an economical thermoplastic with good chemical and temperature resistance. Weir valves sizes 3/4" through 8" are cast iron, ductile iron or cast steel valves and straightway valve sizes 1" through 8" cast iron lined with blue polypropylene. This blue polypropylene complies with FDA requirements for food service. Code of Federal Regulations, GFR 21 Section 177.1520. Because the polypropylene is completely supported by metal, these flanged polypropylene lined valves can be used at temperatures to 200° F (93° C). Color coded blue. Also available in solid polypropylene weir bodies are valve sizes 1/2" through 4". Maximum continuous use temperature is 200° F (93° C).

PVDF

PVDF is a high molecular weight polymer of vinylidene fluoride. It is mechanically strong, thermally stable and resistant to most chemicals and solvents. Valve bodies of solid PVDF are available with threaded ends in sizes 1/2"-2". Cast iron, ductile iron or cast steel flanged valves lined with PVDF (3/16" thick) which complies with FDA requirements. Code of Federal Regulations 177.2510 are available in weir valve sizes 3/4" through 8". Continuous use temperature is 285° F (140° C) for lined valves. Color coded white with tab marked PVDF. Also available in solid PVDF weir bodies are valve sizes 1/2" to 4". Maximum continuous use temperature is 275° F (135° C).

Valve Linings and Solid Plastic Materials Specifications

PVC (Polyvinyl Chloride) and CPVC (Chlorinated Polyvinyl Chloride)

Rigid unplasticized PVC is a tough, chemically resistant thermoplastic that has gained wide acceptance in handling a broad range of corrosive chemicals. PVC piping systems can be threaded, flanged or solvent welded and Dia-Flo® diaphragm valves with solid PVC bodies are available with all three end connections in sizes ½" through 2" as well as 3 and 4" flanged end connections. We also furnish cast iron valves lined with PVC in weir valve sizes ¾" through 8", color coded dark gray. Maximum service temperature for PVC is 140° F (60° C), but solid CPVC valves are available in sizes ½" through 2" for temperatures to 200° F (93° C). Color coded light gray.

Glass

Dia-Flo® weir diaphragm valves are available lined with glass in sizes ½" through 8" with cast iron or ductile iron bodies. The glass lining is a borosilicate glass containing not less than 60% silicon dioxide which is both acid and alkali resistant. Cast iron glass lined valves are capable of withstanding a thermal shock of 100° F (38° C) within the range of 0° to 350° F (-17 to 177° C) and ductile iron glass lined valves, a thermal shock of 180° F (82° C) between 0° to 350° F (-17 to 177° C). Glass lined valves are fully resistant to all concentrations of most acids, except hydrofluoric (HF), fluosilicic acid (H₂SiF₆), and related fluorine compounds at temperatures to 212° F (100° C). For specific recommendations, refer to the Service Guide or contact your local ITT sales representative. At higher temperatures the acid concentration and the water content are important considerations because steam is frequently more corrosive to glass than acids. Color coded blue.

Rubber

Rubber linings can be applied to Dia-Flo® diaphragm valves in weir valve sizes ½" through 12" and straightway valve sizes 1" through 12". These linings are ⅛" thick through 4" valves and ⅜" thick in valve sizes over 4". Rubber linings cover the interior of the valve body as well as the bonnet flange and both end flanges. Standard linings include hard and soft rubber, neoprene, and butyl. Others can be furnished on special order.

Note: Storage Recommendations Lined piping should be stored away from direct sunlight, heat or outdoor seasonal weathering between the time of delivery and use. Flexible type lining may be stored outdoors, providing the piping is covered with protective tarpaulins and not subjected to extreme temperature conditions, such as below 32° F or above 120° F. Avoid sudden changes in temperature. Semi-hard and especially bone hard type lined equipment must be protected and stored, preferably indoors, and should never be subjected to extreme cold climatic conditions because thermal stress and expansion may introduce cracking.

Body Materials Available

Weir Bodies					
Body Type	Material	Identification*	Durometer / FDA Compliant	Maximum Temperature**	
				° F	° C
Metal	Iron	CI or GXXX		350	177
	Ductile Iron	DI or DXXX		350	177
	Carbon Steel	WCB		350	177
	Bronze	B61 or B62		350	177
	Stainless Steel 316	CF8M	FDA	350	177
	CN7M	CN7M		350	177
	Monel	M35		350	177
	Hastelloy	CWXM		350	177
Plastic Lined	PP	Blue	FDA	200	93
	PVC	Grey		140	60
	Kynar® PVDF	White with tab	FDA	285	140
	ETFE	White		300	149
	PFA	Translucent	FDA	350	177
Rubber Lined	Soft Natural	#5	A 55-60	180	82
	Neoprene®	#7	A 60-65	200	93
	Hard Natural	#10	D 40-70	200	93
	Chlorobutyl	#16	A 60-65	200	93
Glass Lined	Borosilicate Glass	Blue Glass	FDA	350	177

Straightway Bodies					
Body Type	Material	Identification*	Durometer / FDA Compliant	Maximum Temperature**	
				° F	° C
Metal	Iron	CI or GXXX		225	107
	Carbon Steel	WCB		225	107
	Stainless Steel 316	CF8M	FDA	225	107
Plastic Lined	PP	Blue	FDA	200	93
	ETFE	White		225	107
Rubber Lined	Soft Natural	#5	A 55-60	180	82
	Neoprene®	#7	A 60-65	200	93
	Hard Natural	#10	D 40-70	200	93
	Chlorobutyl	#16	A 60-65	200	93

*X designates a numerical value

**Temperature may decrease dependent on media, pressure and valve size.

Body Specifications for Lined Valves

Most lined diaphragm valves can be furnished with valve bodies of cast iron, ductile iron or carbon steel. Cast iron is the most economical and is frequently specified for handling low pressure, low temperature corrosive fluids. Ductile iron castings may be specified for more severe conditions or where there is concern about possible breakage of cast iron. Carbon steel may also be specified for more severe operating conditions but ductile iron is normally acceptable as an alternate to carbon steel.

	Ductile Iron	Carbon Steel	Cast Iron
ASTM Designation	A-395	A-216 WCB	A-126
Tensile strength, psi	60,000	70,000	31,000
Tensile yield, psi	40,000	36,000	None
% elongation before fracture	18	22	None

Max pressure rating,

-20° to 100° F (-28° to 38° C)

psi	250	285	200
kPa	1724	1965	1379

Weir Valve Seat and Shell Test Criteria as stated in MSS SP-88†

Test Durations and Test Pressures Based on Diaphragm Maximum Service Pressure Ratings					
Nominal Valve Size	Maximum Pressure Rating psi (bar)	Shell Test Pressure psi (bar)	Minimum Duration of Shell Test Seconds ⁽¹⁾	Seat Test Pressure psi (bar)	Minimum Duration of Seal Test Seconds ⁽¹⁾
1/2 – 1	200 (13.8)	240 (16.5)	15	200 (13.8)	15
1-1/4 – 1-1/2 – 2	175 (12.1)	210 (14.5)	15	175 (12.1)	15
2-1/2 – 4	150 (10.3)	180 (12.4)	60	150 (10.3)	30
6	125 (8.6)	150 (10.3)	60	125 (8.6)	30
8	100 (6.9)	120 (8.3)	60	100 (6.9)	30
10 – 12	65 (4.5)	80 (5.5)	180	65 (4.5)	30

(1)The minimum duration is the period of inspection after the valve is fully prepared and under full test pressure.

Extracted from MSS SP-88-1993, with permission of the publisher, the Manufacturers Standardization Society. Reproduction prohibited under copyright convention unless written permission is granted by the Manufacturers Standardization Society of the Valve and Fittings Industry, Inc.

† Valves with solid plastic bodies, plastic bonnets and/or plastic actuators are limited to 150 psi (10.3 bar) maximum.

Bill of Materials for Weir Type Valves

½"-6"

PARTS			
Item	Description	Material	Quantity
1	Protective Cap	Acrylic	1
2	Adjustable Travel Stop	Stainless Steel	1
3	Stem	Steel, Stainless Steel*	1
4	Bushing	Bronze, Stainless Steel*	1
5	Seal, Wiper	Polyolefin Foam, FKM*, EPDM*	1
6	O-Ring**	Buna N, EPDM*, FKM*	1
7	V-Notch Vent Plug	Stainless Steel (Sealed Only)	AR
8	Handwheel	Cast Iron or PAS, Stainless Steel*, Bronze*, PPT	1
9	Bonnet	Cast Iron, Ductile Iron*, PAS†, PPT, Stainless Steel*, Bronze*	1
10	Compressor	Cast Iron or Zinc, Bronze*, PVDF Coated Cast Iron*	1
11	Spirol Pin	Stainless Steel	1
12	Diaphragm**	Elastomer, PTFE	1
13	Tube Nut	Brass, Stainless Steel*	AR
14	Set Screw	Stainless Steel	SD
15	O-Ring**	Buna N, EPDM*, FKM*	1
16	Thrust Washer	Steel, Stainless Steel*	1
17	O-Ring**	Buna N, EPDM*, FKM*	1
18	Washer, Shim	Polyethylene	AR
19	Bearing, Thrust	Carbon Steel	1
20	Cap, Indicating	Vinyl	1
N/S	Bolting & Nuts	Steel, Stainless Steel*	SD

*Optional materials. †Solid plastic body only. AR—As required SD—Size dependent **Recommended spare parts.

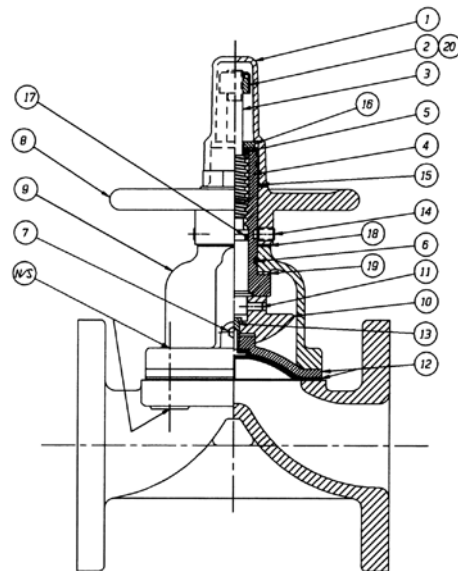

903 BONNET
½" Through 4" Standard
Consult Factory for 6"

8"-12"

PARTS			
Item	Description	Material	Quantity
1	Body Flange	Various	1
2	Diaphragm**	Elastomer, PTFE	1
3	O-Ring**	Buna N	1
4	Nuts	Steel	AR
5	Studs	Steel	AR
6	Bonnet	Cast Iron	1
7	Compressor	Cast Iron	1
8	Pin	Stainless Steel	1
9	Spindle	Steel	1
10	Handwheel	Cast Iron	1
11	Bushing	Brass	1
12	Screw, set	Steel	1
13	Hub, Handwheel	Cast Iron	1
14	Key, Handwheel	Steel	1
15	Fitting Lube	Steel	1
17	Collar, Stop	Steel	1
18	Spindle, Extension, Ind.	Stainless Steel	1
19	Nut, Bushing	Brass	1
20	O-Ring**†	Elastomer	1
21	Bearing, Ball Thrust	Steel	1
22	Bolt	Steel	6
23	Lockwasher	Steel	6
24	Nut	Steel	6
25	Key, Tube Nut	Brass	1
26	Nut, Tube	Brass	1

**Recommended spare parts. †For sealed bonnet only.

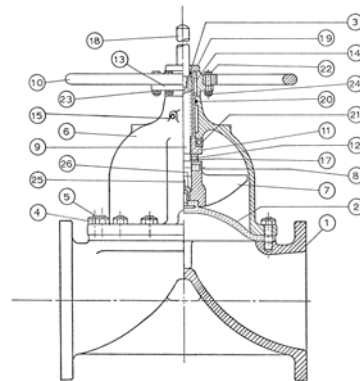

902 BONNET
8" Through 12" Standard

Weir Valve Dimensions

Handwheel Operated Weir Valve

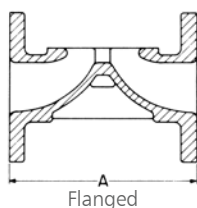
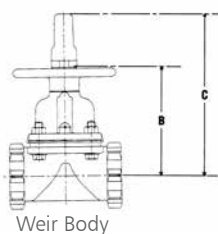

Valve Size		1/2	3/4	1	1 1/4 & 1 1/2	2	2 1/2	3	4	6	8	10	12
Metal Bodies													
Screwed	A	2 1/2	3 3/4	4 1/4	5 1/2	6 1/2	8	10	-	-	-	-	-
Flanged, Unlined	A	4	5 1/2	5 1/2	6 1/2	7 1/2	8 1/2	10	12 1/2	16	20 1/2	25	29 1/2
Flanged, lined:													
Rubber; Neoprene	A	4 1/4	5 3/4	5 3/4	6 3/4	7 3/4	8 3/4	10 1/4	12 3/4	16 3/8	20 7/8	25 3/8	29 7/8
Glass	A	4 1/16	5 9/16	5 9/16	6 9/16	7 9/16	8 9/16	10 1/16	12 7/16	16 1/16	20 9/16	-	-
Plastic; MSS	A	3 3/4	5 3/4	5 3/4	6 7/8	7 7/8	8 7/8	10 1/4	12 7/8	16 3/8	20 7/8	-	-
Plastic; ISO		5.12	5.91	6.30	7.87	9.06		12.20	13.78				
Butt weld (pipe)	A	3 1/2	4	4 1/2	5 1/2	6 1/4	7 5/8	8 3/4	11 1/2	16	20 1/2	-	-
Socket Weld Pipe	A	3 1/2	4	4 1/2	6 1/2	7 1/4	8 3/8	9 3/4	-	-	-	--	-
Socket, Solder (Copper Tube)	A	3 1/2	4 1/8	5 1/16	5 7/8	7 3/8	-	-	-	-	-	-	-
Plastic bodies (Solid)													
Screwed, Socket Weld - A		4.65	5.51	6.34	8.00	8.94	-	-	-	-	-	-	-
Spigot Weld													
DIN - A		3.87	5.37	5.37	6.50	7.50	-	10.88	14.50	-	-	-	-
IPS - A		4.01	5.51	5.51	7.06	7.63	-	10.88	14.50	-	-	-	-
Flanged - A		4.25	5.75	5.75	6.88	7.88	-	10.31	12.94	-	-	-	-
Body Type													
Tolerances													
Unlined Metal		sizes 10" & smaller ± 1/16"						sizes 12" & larger ± 1/8"					
Lined		sizes 10" & smaller ± 1/8"						sizes 12" & larger ± 3/16"					
Glass		sizes 10" & smaller ± 3/32"						sizes 12" & larger ± 1/32"					
Plastic		all sizes ± 1/8"											

Valve Size		.50	.75	1.00	1.25, 1.5	2.00	2.50	3.00	4.00	6.00	8.00	10.00	12.00	
Screwed	B	3.13	3.86	4.65	5.95	6.44	7.84	8.38	-	-	-	-	-	
	C	4.03	5.02	6.01	9.08	9.57	11.95	12.49	-	-	-	-	-	
FLANGED	Unlined & Rubber Lined	B	3.19	4.58	4.58	5.88	6.43	7.77	8.32	10.40	14.33	19.35	22.81	26.24
		C	4.09	5.94	5.94	9.01	9.56	11.88	12.43	15.12	19.80	26.85	31.31	35.62
FLANGED	Plastic Lined & Glass Lined	B	3.11	4.59	4.59	5.82	6.19	7.77	8.07	10.52	14.90	19.73	-	-
		C	4.01	5.95	5.95	8.95	9.32	11.88	12.18	15.24	20.37	27.23	-	-
Weir Bodies of Solid Plastic (with Plastic Bonnet)														
Screwed, Socket Weld Spigot Weld	B	3.0	3.7	4.3	5.4	6.0	-	7.8	10.6	-	-	-	-	
	C	3.9	4.9	5.7	8.5	9.1	-	11.9	15.2	-	-	-	-	
Handwheel Diameter-Metal		3.0	3.0	3.0	6	6	7 3/4	7 3/4	10	14 1/2	19	23	27 1/2	
Handwheel Diameter-Plastic		3.0	3.0	3.0	5.75	5.75	-	7.75	10	-	-	-	-	

ITT Valve End Flange Dimensions (125#, 150#)						
Size, Inches	Diameter of Flange, Inches	Thickness* of Flange (Min) Inches	Diameter of Bolt Circle, Inches	Number of Bolts	Diameter of Bolt Holes, Inches	Diameter of Bolts, Inches
1/2	3 1/2	7/16"	2 3/8	4	5/8	1/2
3/4	4 1/4	7/16"	2 3/4	4	5/8	1/2
1	4 1/4	7/16"	3 1/8	4	5/8	1/2
1 1/4	5	9/16"	3 1/2	4	5/8	1/2
1 1/2	5	9/16"	3 7/8	4	5/8	1/2
2	6	5/8	4 3/4	4	3/4	5/8
2 1/2	7	1 1/16	5 1/2	4	3/4	5/8
3	7 1/2	3/4	6	4	3/4	5/8
4	9	15/16	7 1/2	8	3/4	5/8
6	11	1	9 1/2	8	7/8	3/4
8	13 1/2	1 1/8	11 3/4	8	7/8	3/4
10	16	1 3/16	14 1/4	12	1	7/8
12	19	1 1/4	17	12	1	7/8

* Thickness shown is for unlined stainless steel valve.

Bill of Materials for Straightway Type Valves

PARTS			
Item	Description	Material	Quantity
1	Body Flanged	Cast Iron	1
2	Bonnet	Cast Iron	1
3	Compressor	Cast iron	1
4	Diaphragm	Elastomer	1
5	Bushing	Brass	1
6	Handwheel	Cast Iron	1
7	Spindle	Steel	1
8	Spindle, Extension (indicating)	Stainless Steel	1
9	Insert	Steel	1
10	Spacer	Steel	1
11	Pin, Spirol	Stainless Steel	1
12	Washer, Shim	Polyethylene	AR
13	Bearing, Thrust Needle	Steel	1
14	Bearing, Thrust Race	Steel	2
15	Screw, Set Hex. Soc.	Steel	2
16	Fitting, Lube	Steel	1
17	Screw, Hex head cap	Steel	SD
18	Nut, Hex.	Steel	SD
19	Pin, Spirol	Stainless Steel	1
20	Capseal	Brass	1

AR—As Required SD—Size Dependent

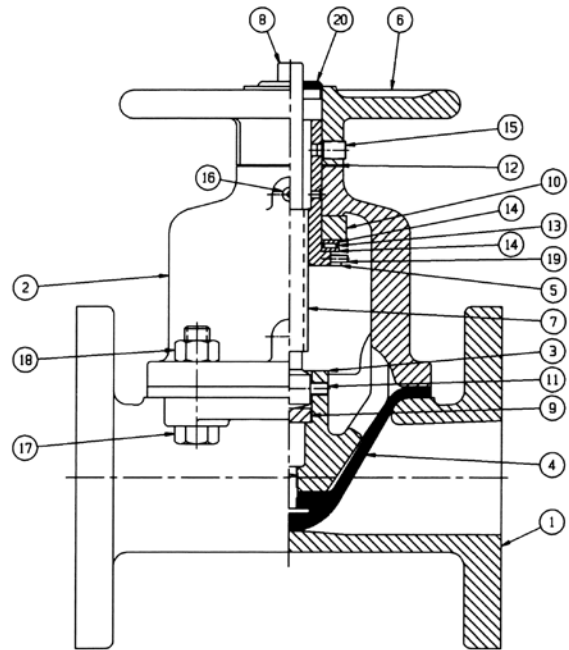

Standard 902 bonnet is shown.
903 bonnet features an extended stem and travel stop.

Straightway Valve Dimensions

Straightway Handwheel Operated Valves

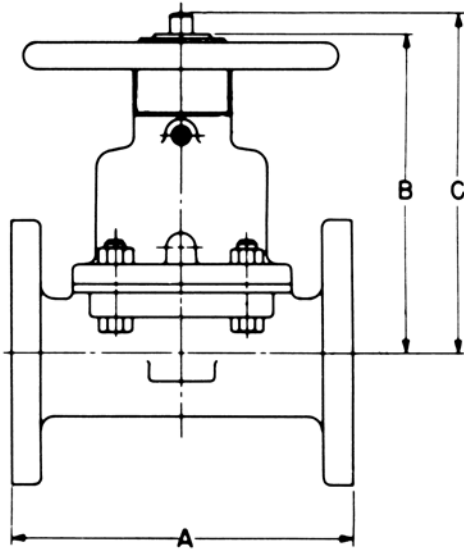

Straightway Valve Dimensions

Body Type	1	1.5	2	2.5	3	4	6	8	10	12
Flanged, Unlined										
A	5.5	6.5	7.5	8.5	10.00	12.5	16.00	20.5	25.00	29.5
B	4.75	5.93	6.96	8.67	8.49	10.61	15.57	19.12	22.00	22.00
C	5.76	7.53	9.16	10.94	11.06	13.91	20.31	25.69	30.00	30.00
Flanged, Rubber Lined										
A	5.75	6.75	7.75	8.75	10.25	12.75	16.38	20.88	25.38	29.88
B	4.75	5.93	6.96	8.67	8.49	10.61	15.57	19.12	22.00	22.00
C	5.76	7.53	9.16	10.94	11.06	13.91	20.31	25.69	30.00	30.00
Flanged, Plastic Lined										
A	5.75	6.88	7.88	-	10.25	12.88	16.38	20.88	-	-
B	4.81	6.00	7.03	-	8.55	10.68	15.51	19.00	-	-
C	5.82	7.60	9.22	-	11.12	13.97	20.25	25.57	-	-

Bill of Materials

Series 3312 Double Acting

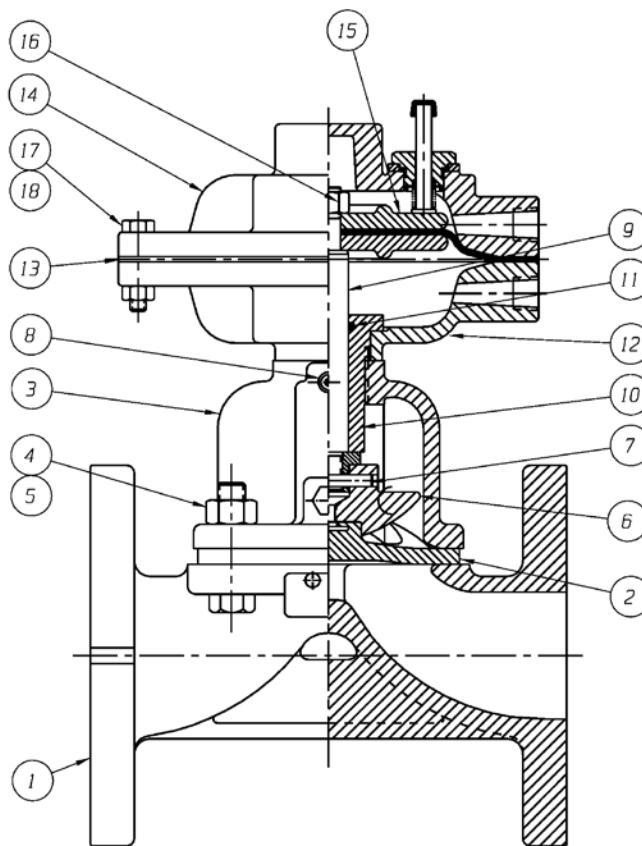

LIST OF PARTS			
ITEM	DESCRIPTION	MATERIAL	QTY.
1	BODY, FLANGED	-	1
2	DIAPHRAGM, ELASTOMER	-	1
3	BONNET, ADAPTER	DUCTILE IRON	1
4	HEX, CAP SCREWS OR STUDS	STEEL	4
5	NUTS	STEEL	4
6	COMPRESSOR, F/ ELASTOMER DIAPHRAGM	ZINC	1
7	PIN, SPIROL	STN. STL.	1
8	FITTING, LUBE	-	1
9	SPINDLE, VALVE	STN. STL.	1
10	BUSHING, ADAPTER	-	1
11	O-RING	BUNA-N	AR
12	COVER, LOWER	ALUMINUM	1
13	DIAPHRAGM, AIR MOTOR	BUNA-N	1
14	COVER, UPPER	ALUMINUM	1
15	PLATE, ACTUATOR	ALUMINUM	2
16	NUT, HEX.	CAR. STL.	1
17	SCREW, HEX HD. CAP	CAR. STL.	12
18	NUT, HEX.	CAR. STL.	12

Dimensional Data for Valves with Actuators

Series 3312 Double Acting

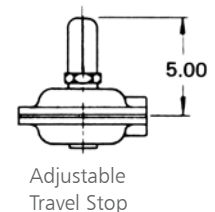
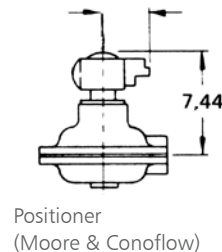
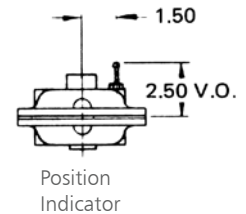
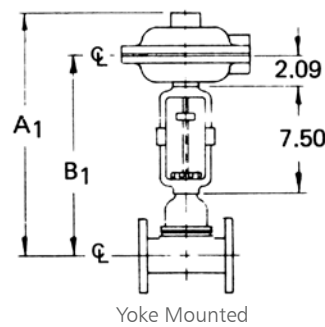
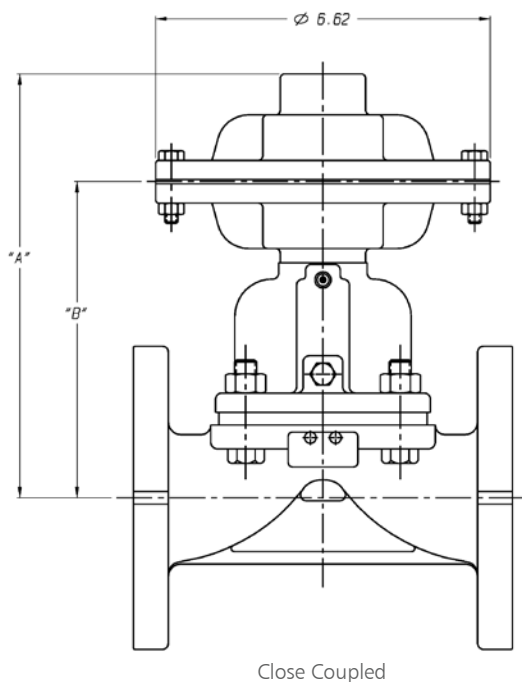

LIMIT SWITCHES	J	K
BZE6-2RN or DTE6-2RN	4.75	9.12
BAF1-2RN-RH or DTF2-2RN-RH	5.00	9.12
EX-Q or EXD-Q	5.75	10.00

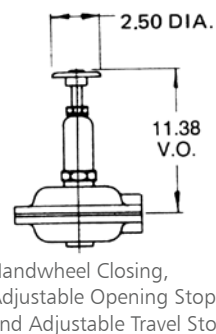
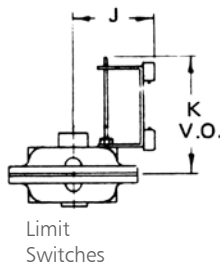

Weir Valves					
Valve Size	Close Coupled		Yoke Mounted		Ends
	A	B	A1	B1	
1/2	5.71	3.58	13.93	11.80	Screwed
	5.65	3.52	13.87	11.74	Flanged
3/4	6.32	4.20	14.35	12.23	Screwed
	6.65	4.53	14.68	12.56	Flanged
1	6.84	4.72	14.87	12.75	Screwed
	6.65	4.53	14.68	12.56	Flanged
1 1/4 - 1 1/2	8.25	6.12	16.78	14.65	Screwed
	8.05	5.93	16.58	14.46	Flanged
2	8.74	6.61	17.27	15.14	Screwed
	8.61	6.48	17.14	15.01	Flanged

Dualrange Valves					
Valve Size	Close Coupled		Yoke Mounted		Ends
	A	B	A1	B1	
1	8.98	6.85	16.48	14.35	Screwed
	8.79	6.66	16.29	14.16	Flanged

Bill of Materials

Series 3112 Direct Acting

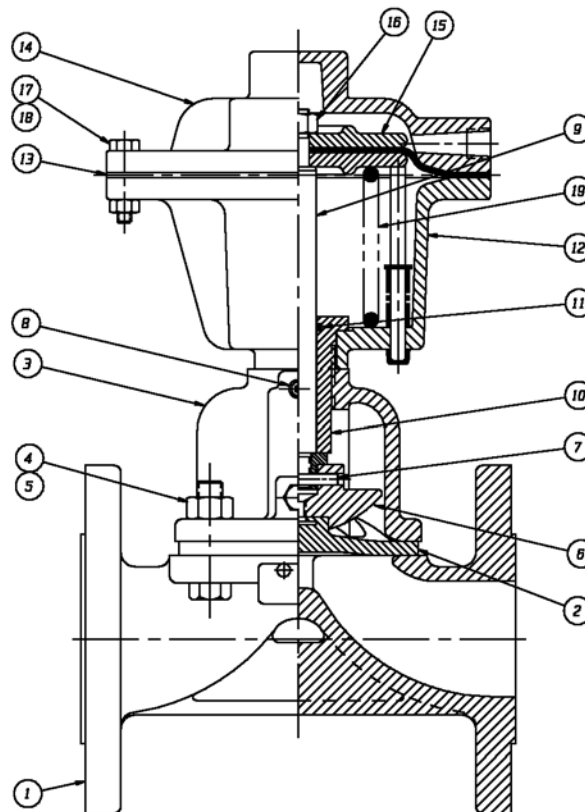

LIST OF PARTS			
ITEM	DESCRIPTION	MATERIAL	QTY.
1	BODY, FLANGED	-	1
2	DIAPHRAGM, ELASTOMER	-	1
3	BONNET, ADAPTER	DUCTILE IRON	1
4	HEX, CAP SCREWS OR STUDS	STEEL	4
5	NUTS	STEEL	4
6	COMPRESSOR, F/ ELASTOMER DIAPHRAGM	ZINC	1
7	PIN, SPIROL	STN. STL.	1
8	FITTING, LUBE	-	1
9	SPINDLE, VALVE	STN. STL.	1
10	BUSHING, ADAPTER	-	1
11	O-RING	BUNA-N	AR
12	COVER, LOWER	ALUMINUM	1
13	DIAPHRAGM, AIR MOTOR	BUNA-N	1
14	COVER, UPPER	ALUMINUM	1
15	PLATE, ACTUATOR	ALUMINUM	2
16	NUT, , HEX	CAR. STL.	1
17	SCREW, HEX HD CAP	CAR. STL.	12
18	NUT, HEX	CAR. STL.	12
19	SPRING	STEEL	AR

Dimensional Data

Series 3112 Direct Acting

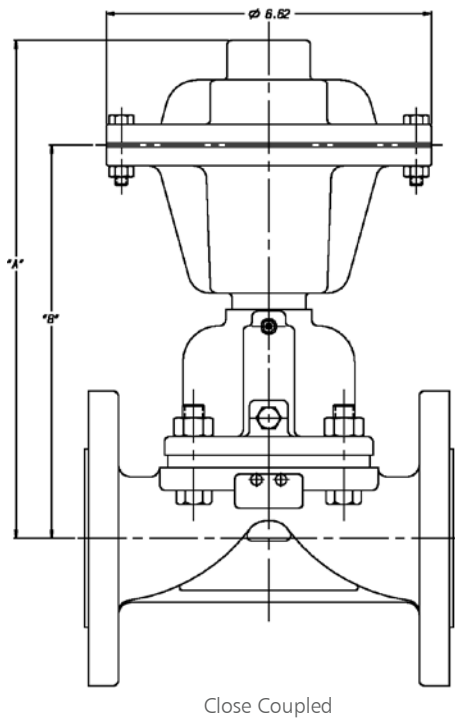

Close Coupled

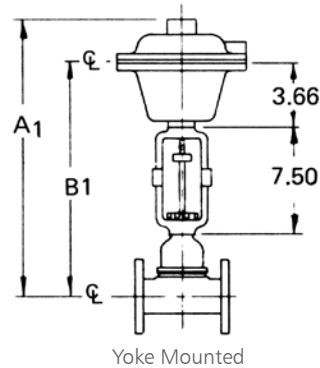

Yoke Mounted

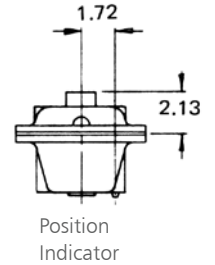

Position Indicator

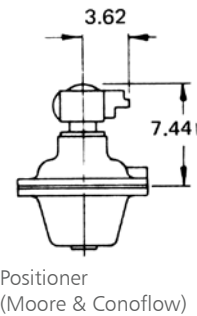

Positioner
(Moore & Conoflow)

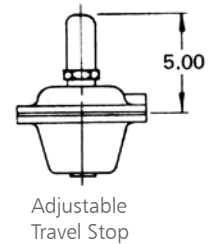

Adjustable
Travel Stop

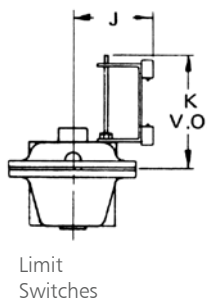

Limit
Switches

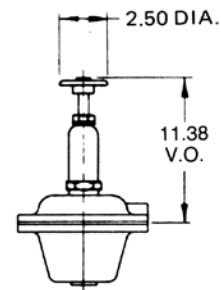

Handwheel Closing,
Adjustable Opening Stop,
and Adjustable Travel Stop

LIMIT SWITCHES			J	K
BZE6-2RN or DTE6-2RN	4.75	9.12		
BAF1-2RN-RH or DTF2-2RN-RH	5.00	9.12		
EX-Q or EXD-Q	5.75	10.00		

Weir Valves					
Valve Size	Close Coupled		Yoke Mounted		Ends
	A	B	A1	B1	
1/2	7.27	5.14	15.50	13.37	Screwed
	7.21	5.08	15.44	13.31	Flanged
3/4	7.88	5.76	15.92	13.80	Screwed
	8.21	6.09	16.25	14.13	Flanged
1	8.40	6.28	16.44	14.32	Screwed
	8.21	6.09	16.25	14.13	Flanged
1 1/4 - 1 1/2	9.80	7.68	18.34	16.22	Screwed
	9.61	7.49	18.15	16.03	Flanged
2	10.49	8.36	18.84	16.71	Screwed
	10.36	8.23	18.71	16.58	Flanged

Dualrange Valves					
Valve Size	Close Coupled		Yoke Mounted		Ends
	A	B	A1	B1	
1	10.55	8.46	18.05	15.92	Screwed
	10.36	8.23	17.86	15.73	Flanged

Bill of Materials

Series 3213-16 Reverse Acting

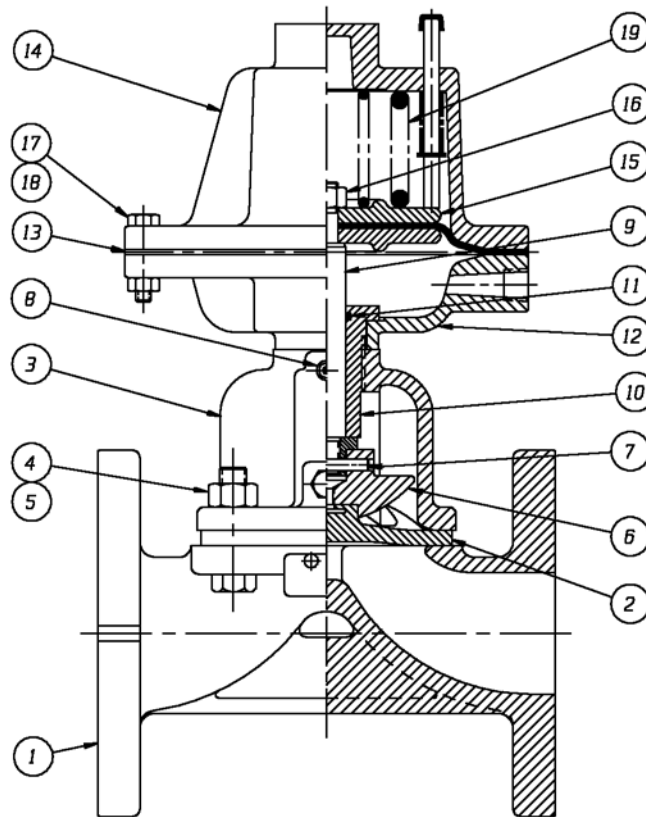

LIST OF PARTS			
ITEM	DESCRIPTION	MATERIAL	QTY.
1	BODY, FLANGED	-	1
2	DIAPHRAGM, ELASTOMER	-	1
3	BONNET, ADAPTER	DUCTILE IRON	1
4	HEX, CAP SCREWS OR STUDS	STEEL	4
5	NUTS	STEEL	4
6	COMPRESSOR, F/ ELASTOMER DIAPHRAGM	ZINC	1
7	PIN, SPIROL	STN. STL.	1
8	FITTING, LUBE	-	1
9	SPINDLE, VALVE	STN. STL.	1
10	BUSHING, ADAPTER	-	1
11	O-RING	BLUNA-N	AR
12	COVER, LOWER	ALUMINUM	1
13	DIAPHRAGM, AIR MOTOR	BLUNA-N	1
14	COVER, UPPER	ALUMINUM	1
15	PLATE, ACTUATOR	ALUMINUM	2
16	NUT,, HEX	CAR. STL.	1
17	SCREW, HEX HD CAP	CAR. STL.	12
18	NUT, HEX	CAR. STL.	12
19	SPRING	STEEL	AR

Dimensional Data

Series 3213-16 Reverse Acting

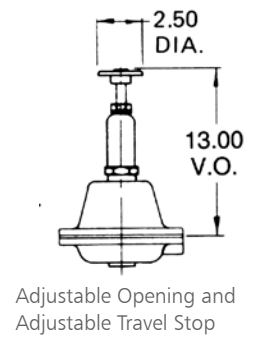
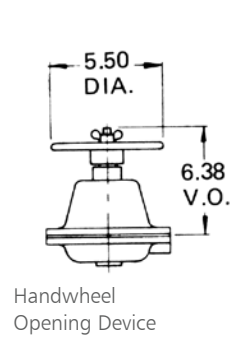
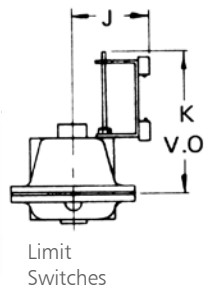
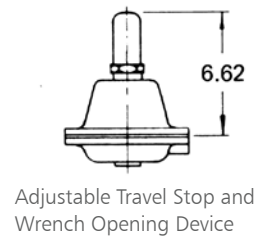
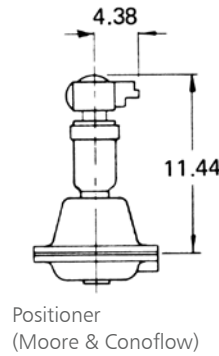
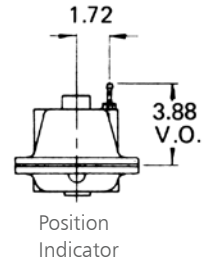
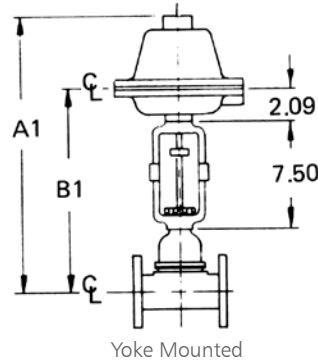
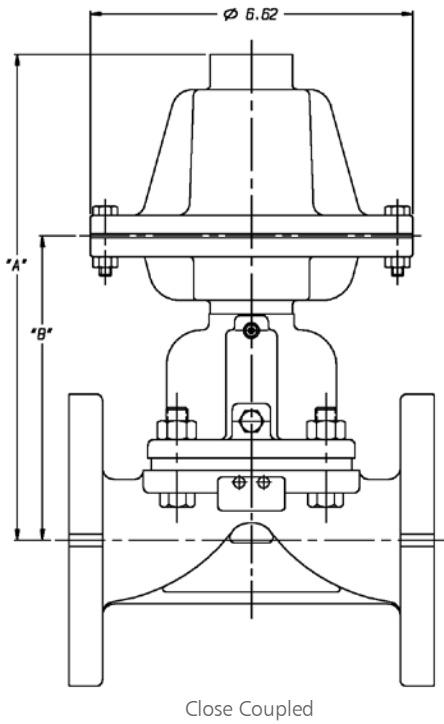

LIMIT SWITCHES		
BZE6-2RN or DTE6-2RN	J	K
BAF1-2RN-RH or DTF2-2RN-RH	5.00	10.62
EX-Q or EXD-Q	5.75	11.56

Weir Valves					
Valve Size	Close Coupled		Yoke Mounted		Ends
	A	B	A1	B1	
1/2	7.31	3.58	15.53	11.80	Screwed
	7.25	3.52	15.47	11.74	Flanged
3/4	7.92	4.20	15.95	12.23	Screwed
	8.25	4.53	16.28	12.56	Flanged
1	8.44	4.72	16.47	12.75	Screwed
	8.25	4.53	16.28	12.56	Flanged
1 1/4 - 1 1/2	9.84	6.12	18.37	14.65	Screwed
	9.65	5.93	18.18	14.46	Flanged
2	10.34	6.61	18.87	15.14	Screwed
	10.21	6.48	18.74	15.01	Flanged

Dualrange Valves					
Valve Size	Close Coupled		Yoke Mounted		Ends
	A	B	A1	B1	
1	10.58	6.85	18.08	14.35	Screwed
	10.39	6.66	17.89	14.16	Flanged

Bill of Materials

Series 3325 Double Acting

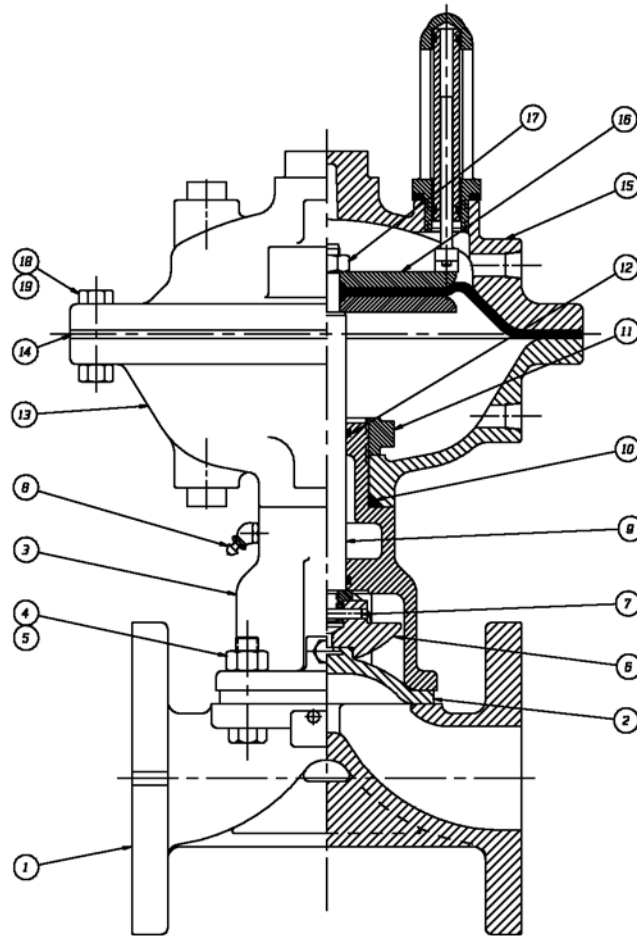

LIST OF PARTS			
ITEM	DESCRIPTION	MATERIAL	QTY.
1	BODY, FLANGED	-	1
2	DIAPHRAGM, ELASTOMER	-	1
3	BONNET, ADAPTER	-	1
4	HEX, CAP SCREWS OR STUDS	-	4
5	NUTS	-	4
6	COMPRESSOR, F/ ELASTOMER DIAPHRAGM	-	1
7	PIN, SPIROL	STN. STL.	1
8	FITTING, LUBE	-	1
9	SPINDLE, VALVE	STN. STL.	1
10	O-RING	BUNA-N	1
11	NUT, ADAPTER BUSHING	D.I.	1
12	O-RING	BUNA-N	1
13	COVER, LOWER	ALUMINUM	1
14	DIAPHRAGM, AIR MOTOR	BUNA-N	1
15	COVER, UPPER	ALUMINUM	1
16	PLATE, ACTUATOR	C.I.	2
17	NUT, HEX JAM	CAR. STL.	1
18	SCREW, HEX HD. CAP	CAR. STL.	9
19	NUT, HEX	CAR. STL.	9

Dimensional Data

Series 3325 Double Acting

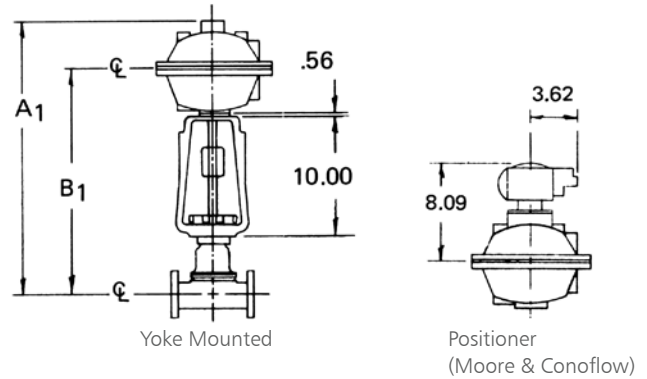
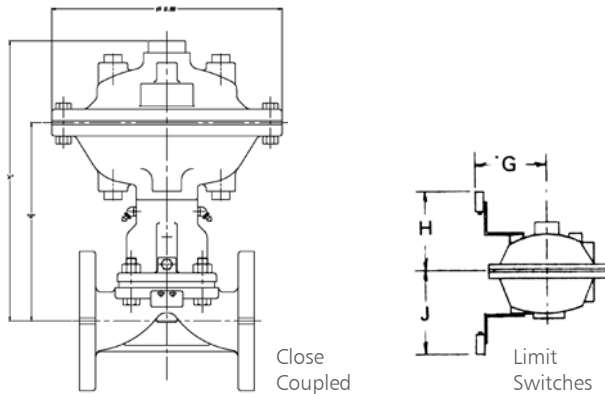

LIMIT SWITCHES			
	G	H	J
BZE6-2RN/ DTE6-2RN	5.94	6.53	6.94
BAF1-2RN-RH/DTF2-2RN-RH	6.25	7.12	7.50
EX-Q/ EXD-Q	6.94	8.31	8.69

Weir Valves					
Valve Size	Close Coupled		Yoke Mounted		Ends
	A	B	A1	B1	
1	10.35	6.83	20.92	17.39	Screwed
	10.16	6.64	20.73	17.20	Flanged
1 ¼ - 1 ½	11.89	8.37	22.46	18.94	Screwed
	11.70	8.18	22.27	18.75	Flanged
2	12.37	8.85	22.44	19.42	Screwed
	12.24	8.72	22.31	19.29	Flanged
2 ½	13.40	9.88	23.97	20.45	Screwed
	13.21	9.69	23.78	20.26	Flanged
3	13.94	10.42	24.51	20.99	Screwed
	13.76	10.24	24.33	20.81	Flanged
4	15.10	11.58	25.67	22.15	Flanged

Straightway Valves					
Valve Size	Close Coupled		Yoke Mounted		Ends
	A	B	A1	B1	
1	11.15	7.50	21.71	18.06	Flanged
1 ½	12.05	8.40	22.61	18.96	Flanged
2	13.09	9.44	23.65	20.00	Flanged
2 ½	14.26	10.61	24.82	21.17	Flanged

Dualrange Valves					
Valve Size	Close Coupled		Yoke Mounted		Ends
	A	B	A1	B1	
1	12.27	8.62	22.83	19.18	Screwed
	12.08	8.43	22.64	18.99	Flanged
1 ½	14.24	10.59	24.80	21.15	Screwed
	14.05	10.40	24.61	20.96	Flanged
2	14.35	10.70	24.91	21.26	Screwed
	14.22	10.57	24.78	21.13	Flanged
2 ½	15.47	11.82	26.03	22.38	Screwed
	15.28	11.63	25.84	22.19	Flanged
3	16.65	13.00	27.21	23.56	Screwed
	16.47	12.82	27.03	23.38	Flanged

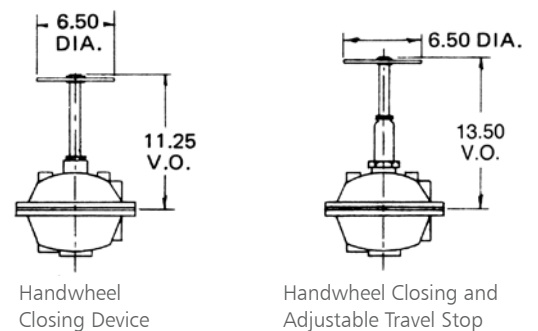
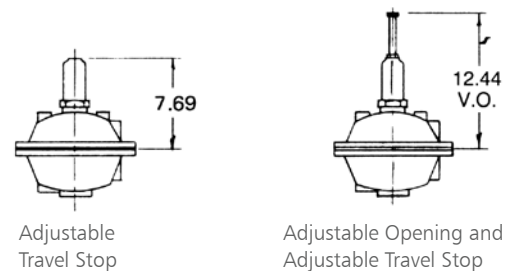
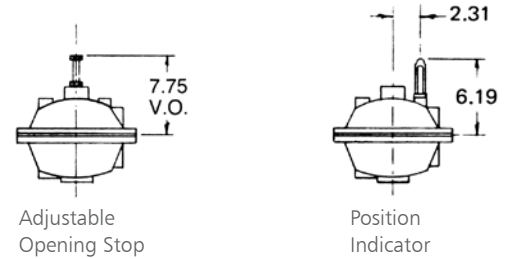

Bill of Materials

Series 3125 Direct Acting

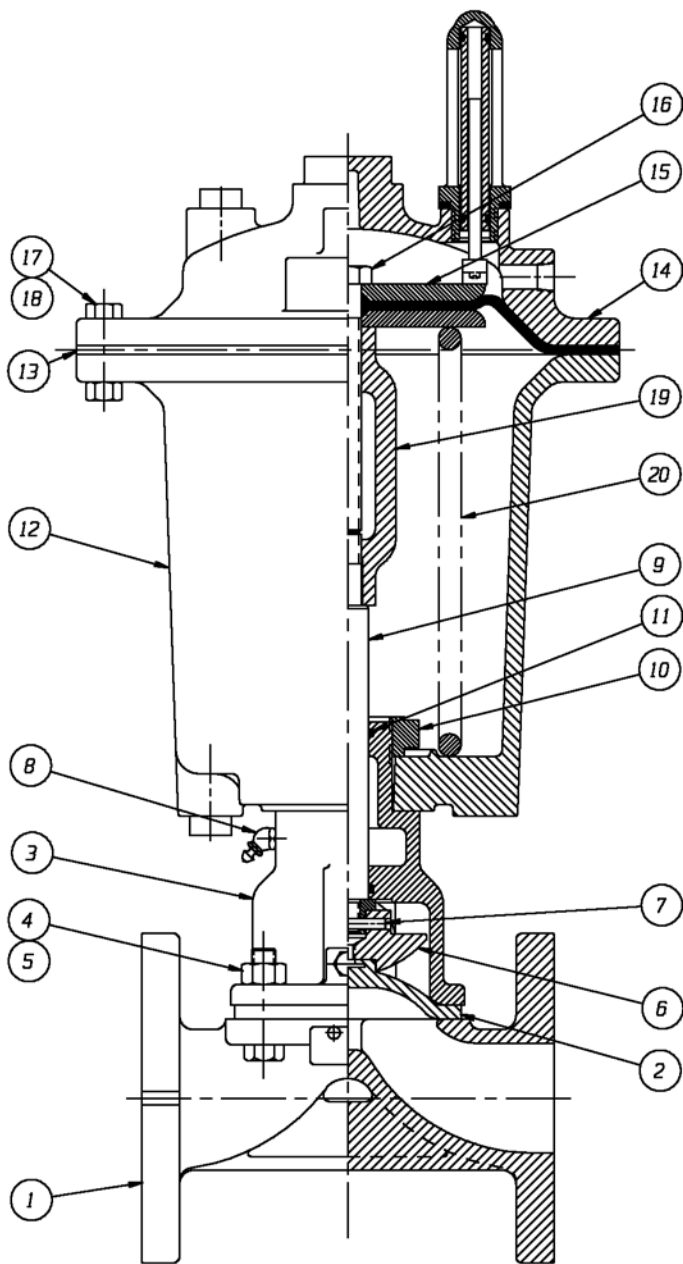

LIST OF PARTS			
ITEM	DESCRIPTION	MATERIAL	QTY.
1	BODY, FLANGED	-	1
2	DIAPHRAGM, ELASTOMER	-	1
3	BONNET, ADAPTER	-	1
4	HEX, CAP SCREWS OR STUDS	-	4
5	NUTS	-	4
6	COMPRESSOR, F/ ELASTOMER DIAPHRAGM	-	1
7	PIN, SPIROIL	STN. STL.	1
8	FITTING, LUBE	-	1
9	SPINDLE, VALVE	STN. STL.	1
10	NUT, ADAPTER BUSHING	DI.	1
11	O-RING	BUNA-N	1
12	COVER, LOWER	ALUMINUM	1
13	DIAPHRAGM, AIR MOTOR	BUNA-N	1
14	COVER, UPPER	ALUMINUM	1
15	PLATE, ACTUATOR	CI.	1
16	SCREW, HEX HD CAP	C. STL.	1
17	SCREW, HEX HD. CAP	C. STL.	9
18	NUT, HEX	C. STL.	9
19	SPINDLE, HEAD	DI.	1
20	SPRING # 103	STEEL	1

Dimensional Data

Series 3125 Direct Acting

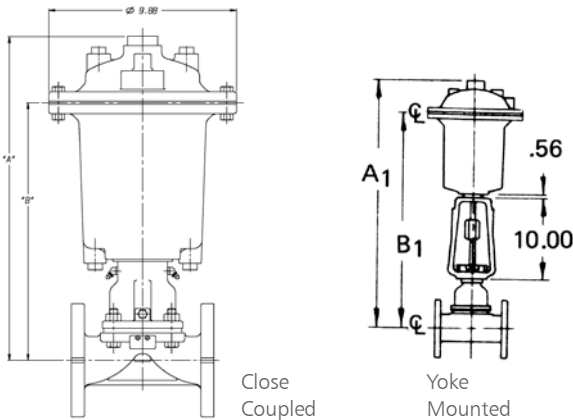

LIMIT SWITCHES	H	J	K	L
BZE6-2RN or DTE6-2RN	5.94	6.56	12.38	6.12
BAF1-2RN-RH or DTF2-2RN-RH	6.25	7.12	12.94	6.44
EX-Q or EXD-Q	6.94	8.31	13.12	7.12

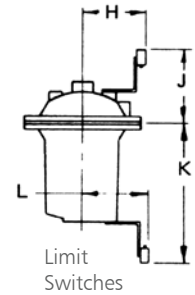
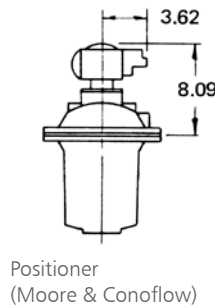

Weir Valves					
Valve Size	Close Coupled		Yoke Mounted		Ends
	A	B	A1	B1	
1	15.41	11.89	25.98	22.45	Screwed
	15.22	11.70	25.79	22.26	Flanged
1 ¼ – 1 ½	16.95	13.43	27.52	24.00	Screwed
	16.76	13.24	27.33	23.81	Flanged
2	17.43	13.91	28.00	24.48	Screwed
	17.30	13.78	27.87	24.35	Flanged
2 ½	17.89	14.37	28.46	25.94	Screwed
	17.70	14.18	28.27	25.75	Flanged
3	19.00	15.48	29.59	26.05	Screwed
	18.82	15.30	29.39	25.87	Flanged
4	20.16	16.64	30.73	27.21	Flanged

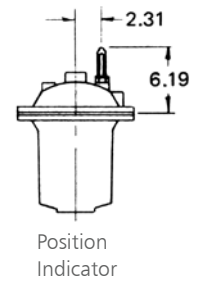
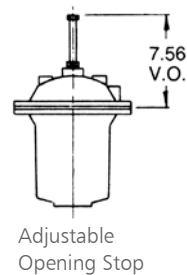

Straightway Valves					
Valve Size	Close Coupled		Yoke Mounted		Ends
	A	B	A1	B1	
1	16.21	12.56	26.77	23.12	Flanged
1 ½	17.11	13.46	27.67	24.02	Flanged
2	18.15	14.50	28.71	25.06	Flanged

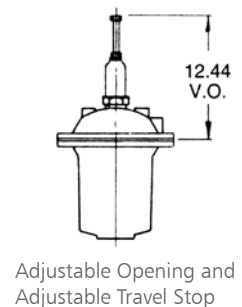
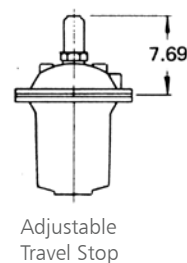

Dualrange Valves					
Valve Size	Close Coupled		Yoke Mounted		Ends
	A	B	A1	B1	
1	17.33	13.68	27.89	24.24	Screwed
	17.14	13.49	27.70	24.05	Flanged
1 ½	19.30	15.65	29.86	26.21	Screwed
	19.11	15.46	29.67	26.02	Flanged
2	19.41	15.76	29.97	26.32	Screwed
	19.28	15.63	29.84	26.19	Flanged
2 ½	20.53	16.88	31.09	27.44	Screwed
	20.34	16.69	30.90	27.25	Flanged
3	21.71	18.06	32.27	28.62	Screwed
	21.53	17.88	32.09	28.44	Flanged

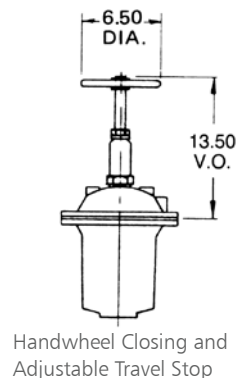
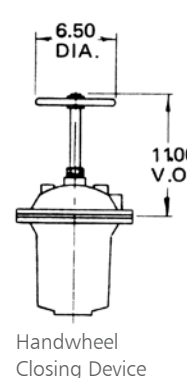

Bill of Materials

Series 3226-28 Reverse Acting

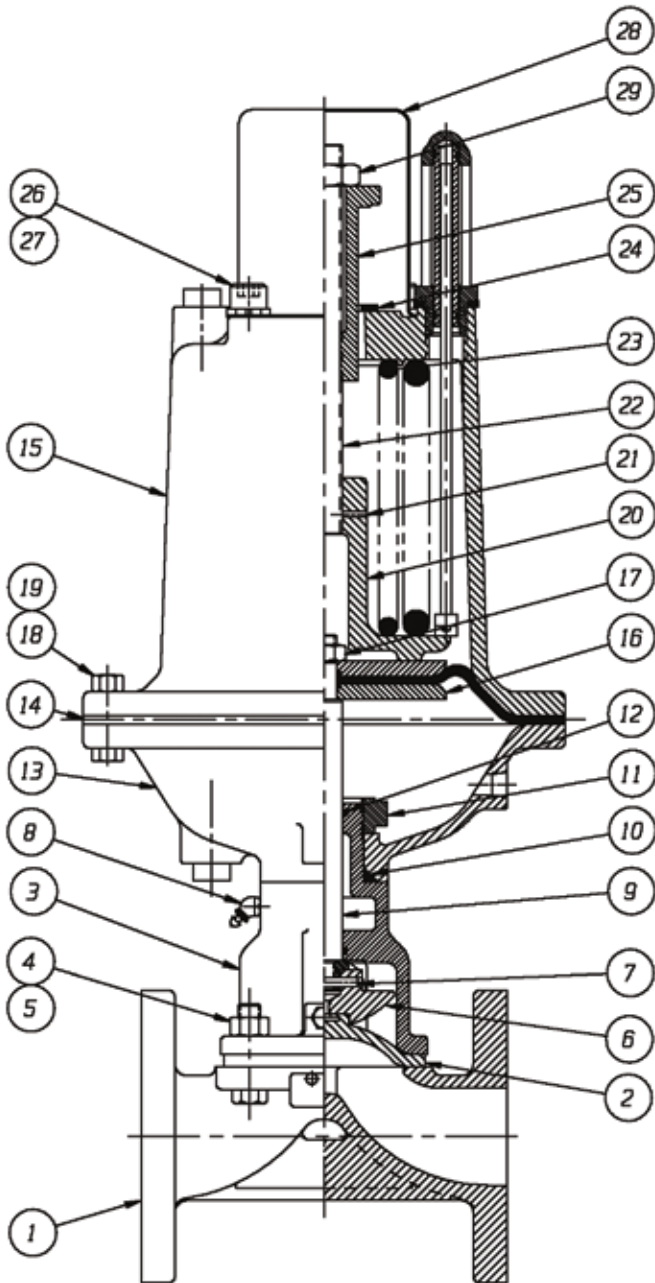

LIST OF PARTS			
ITEM	DESCRIPTION	MATERIAL	QTY.
1	BODY, FLANGED FLAT FACE	-	1
2	DIAPHRAGM, ELASTOMER	-	1
3	BONNET, ADAPTER	-	1
4	HEX, CAP SCREWS OR STUDS	-	4
5	NUTS	-	4
6	COMPRESSOR, F/ ELASTOMER DIAPHRAGM	-	1
7	PIN, SPIROL	STN. STL.	1
8	FITTING, LUBE #1744-B	-	1
9	SPINDLE, VALVE	STN. STL.	1
10	O-RING #326	BLMA-N	1
11	NUT, ADAPTER BUSHING	DI.	1
12	O-RING 'SEE CHART'	BLMA-N	1
13	COVER, LOWER	ALUMINUM	1
14	DIAPHRAGM, AIR MOTOR	BLMA-N	1
15	COVER, UPPER	ALUMINUM	1
16	PLATE, ACTUATOR	CI.	2
17	NUT, HEX JAM	C.STL.	1
18	SCREW, HEX HD. CAP	C.STL.	9
19	NUT, HEX	C.STL.	9
20	SEAT, SPRING	CI.	1
21	PIN, SPIROL (SPRING SEAT)	STN. STL.	1
22	ROD, SPRING	C.STL.	1
23	SPRING NO. 102A	STEEL	AR
24	WASHER, THRUST	C.STL.	1
25	BUSHING, ADJUSTING	DI.	1
26	SCREW, HEX. SOC. HD. CAP	C.STL.	2
27	WASHER, SPRINGLOCK	C.STL.	2
28	SHIELD, TRAVEL STOP	C.STL.	1
29	NUT, HEX. JAM	C.STL.	1

Dimensional Data

Series 3226-28 Reverse Acting

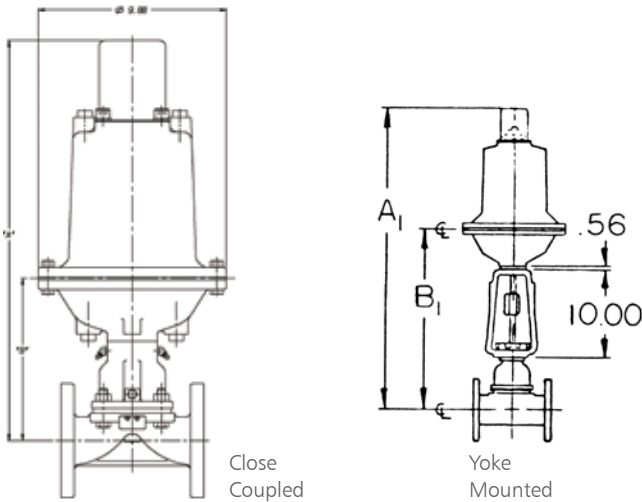

LIMIT SWITCHES	H	J	K	L
BZE6-2RN or DTE6-2RN	6.12	12.38	6.94	5.94
BAF1-2RN-RH or DTF2-2RN-RH	6.38	12.94	7.50	6.25
EX-Q or EXD-Q	7.12	13.12	8.68	6.94

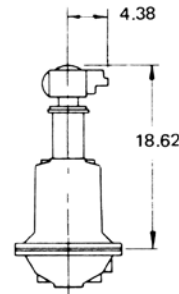

Positioner
(Moore & Conoflow)

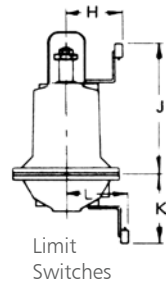

Limit
Switches

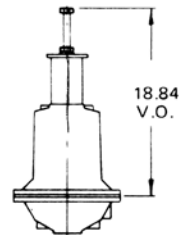

Adjustable
Opening Stop

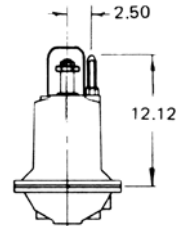

Position
Indicator

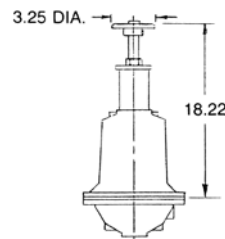

Adjustable Opening Stop
with Handwheel

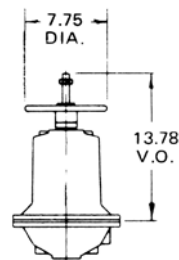

Handwheel
Opening Device

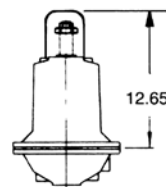

Wrench
Opening Device

Weir Valves					
Valve Size	Close Coupled		Yoke Mounted		Ends
	A	B	A1	B1	
1	19.35	6.83	29.92	17.39	Screwed
	19.16	6.64	29.73	17.20	Flanged
1 ¼ – 1 ½	20.89	8.37	31.46	18.94	Screwed
	20.70	8.18	31.27	18.75	Flanged
2	21.37	8.85	31.94	19.42	Screwed
	21.24	8.72	31.81	19.29	Flanged
2 ½	22.40	9.88	32.97	20.45	Screwed
	22.21	9.69	32.78	20.26	Flanged
3	22.94	10.42	33.51	20.99	Screwed
	22.76	10.24	33.33	20.81	Flanged
4	24.10	11.58	34.67	22.15	Flanged

Straightway Valves					
Valve Size	Close Coupled		Yoke Mounted		Ends
	A	B	A1	B1	
1	20.15	7.50	30.71	18.06	Flanged
1 ½	21.05	8.40	31.61	18.96	Flanged

Dualrange Valves					
Valve Size	Close Coupled		Yoke Mounted		Ends
	A	B	A1	B1	
1	21.27	8.62	31.83	19.18	Screwed
	21.08	8.43	31.64	18.99	Flanged
1 ½	23.24	10.59	33.80	21.15	Screwed
	23.05	10.40	33.61	20.96	Flanged
2	23.35	10.70	33.91	21.26	Screwed
	23.22	10.57	33.78	21.13	Flanged
2 ½	24.47	11.82	35.03	22.38	Screwed
	24.28	11.63	34.84	22.19	Flanged

Bill of Materials

Series 3350 Double Acting

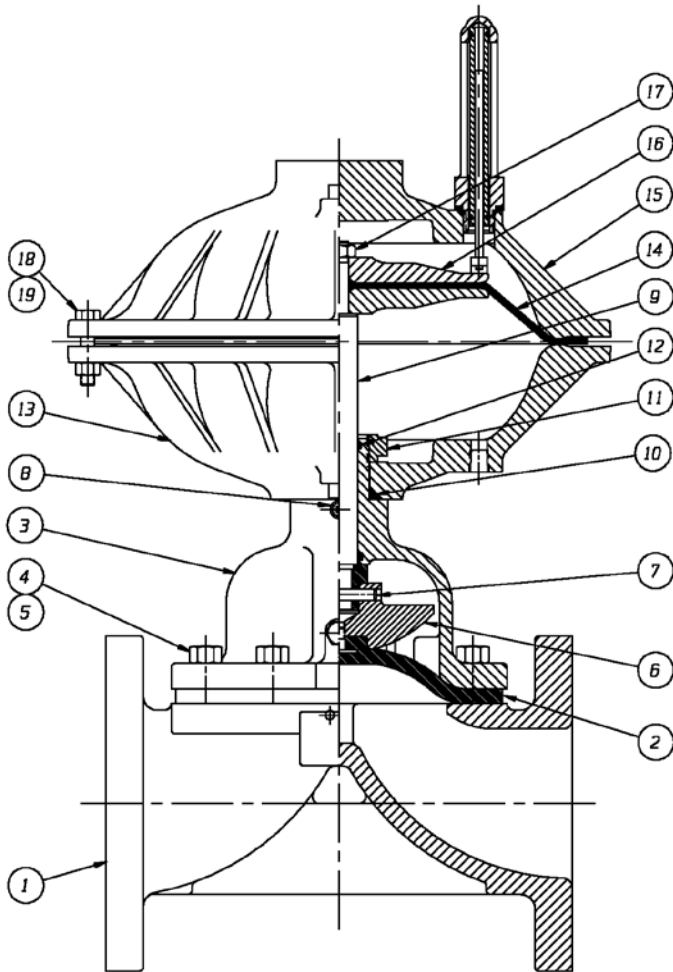

LIST OF PARTS			
ITEM	DESCRIPTION	MATERIAL	QTY.
1	BODY, FLANGED	-	1
2	DIAPHRAGM, ELASTOMER	-	1
3	BONNET, ADAPTER	-	1
4	HEX. CAP SCREWS OR STUDS	-	4
5	NUTS	-	4
6	COMPRESSOR, F/ ELASTOMER DIAPHRAGM	-	1
7	PIN, SPIRAL	STN. STL.	1
8	FITTING, LUBE	-	1
9	SPINDLE, VALVE	STN. STL.	1
10	O-RING	ELMA-N	1
11	NUT, ADAPTER BUSHING	D.I.	1
12	O-RING	ELMA-N	1
13	COVER, LOWER	ALUMINUM	1
14	DIAPHRAGM, AIR MOTOR	ELMA-N	1
15	COVER, UPPER	ALUMINUM	1
16	PLATE, ACTUATOR	C.I.	2
17	NUT, HEX JAM	CAR. STL.	1
18	SCREW, HEX HD. CAP	CAR. STL.	9
19	NUT, HEX	CAR. STL.	9

Dimensional Data

Series 3350 Double Acting

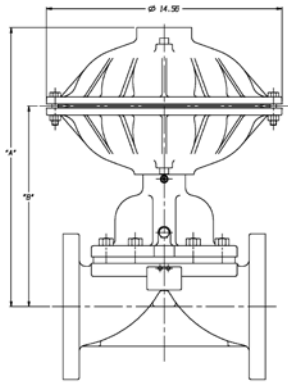

Close Coupled

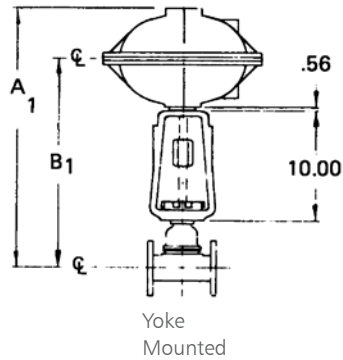

Yoke Mounted

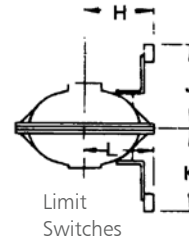

Limit Switches

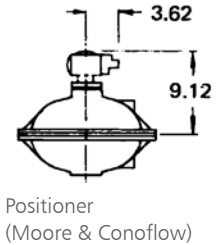

Positioner
(Moore & Conoflow)

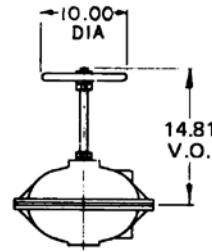

Handwheel Closing Device

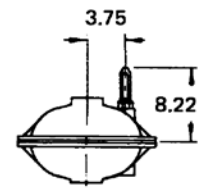

Position Indicator

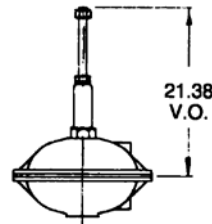

Adjustable Opening and Adjustable Travel Stop

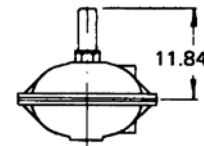

Adjustable Travel Stop

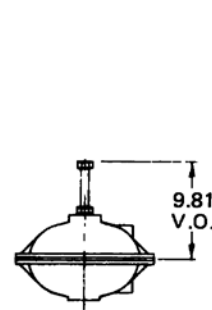

Adjustable Opening Stop

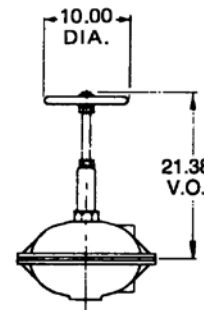

Handwheel Closing and Adjustable Travel Stop

Weir Valves

Valve Size	Close Coupled		Yoke Mounted		Ends
	A	B	A1	B1	
1 1/4 - 1 1/2	14.03	9.26	24.60	19.83	Screwed
	13.84	9.07	24.41	19.64	Flanged
2	14.51	9.74	25.08	20.31	Screwed
	14.38	9.61	24.95	20.18	Flanged
2 1/2	15.54	10.77	26.11	21.34	Screwed
	15.35	10.58	25.92	21.15	Flanged
3	16.08	11.31	26.65	21.88	Screwed
	15.90	11.13	26.47	21.70	Flanged
4	17.24	12.47	27.81	22.04	Flanged
6	20.69	15.92	31.26	26.50	Flanged

Straightway Valves

Valve Size	Close Coupled		Yoke Mounted		Ends
	A	B	A1	B1	
1	13.22	8.45	23.79	19.02	Flanged
1 1/2	14.03	9.28	24.59	19.84	Flanged
2	15.07	10.32	25.63	20.88	Flanged
2 1/2	16.24	11.49	26.80	22.05	Flanged
3	16.06	11.31	26.62	21.87	Flanged
4	17.56	12.81	28.12	23.37	Flanged

Dualrange Valves

Valve Size	Close Coupled		Yoke Mounted		Ends
	A	B	A1	B1	
1 1/2	16.22	11.47	26.78	22.03	Screwed
	16.03	11.28	26.59	21.84	Flanged
2	16.33	11.58	26.89	22.14	Screwed
	16.20	11.45	26.76	22.01	Flanged
2 1/2	17.45	12.70	28.01	23.26	Screwed
	17.26	12.51	27.82	23.07	Flanged
3	18.63	13.88	29.19	24.44	Screwed
	18.45	13.70	29.01	24.26	Flanged
4	19.99	15.24	30.55	25.80	Flanged
6	23.72	18.97	34.28	29.53	Flanged

Bill of Materials

Series 3150 Direct Acting

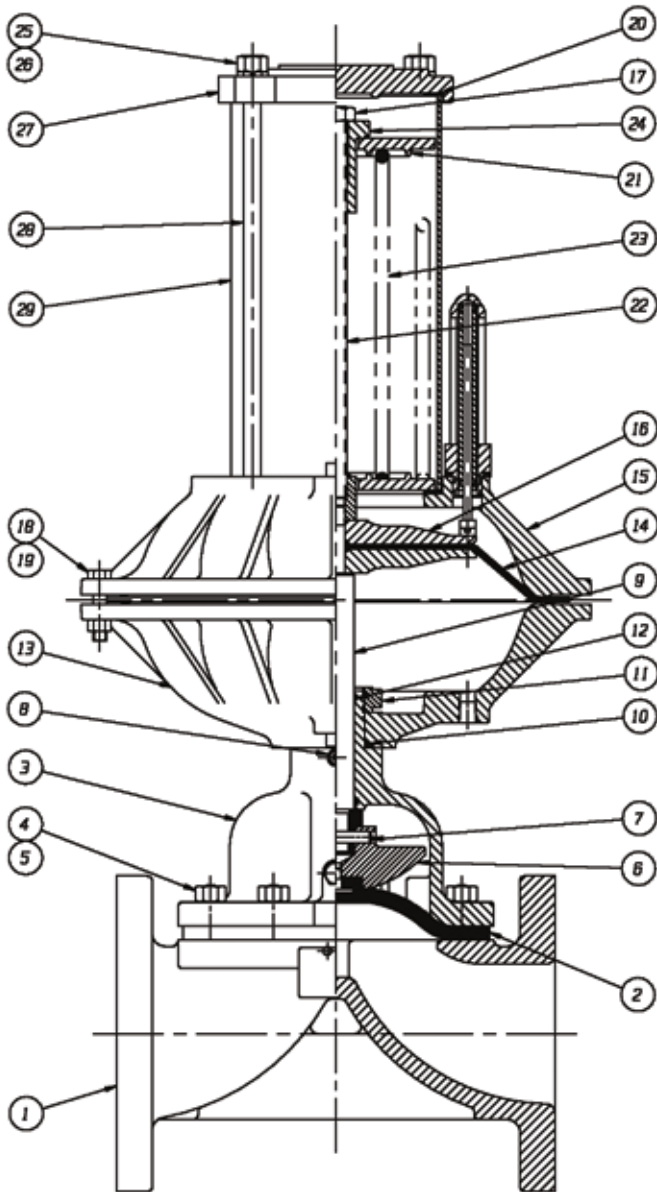

LIST OF PARTS			
ITEM	DESCRIPTION	MATERIAL	QTY.
1	BODY, FLANGED FLAT FACE	-	1
2	DIAPHRAGM, ELASTOMER	-	1
3	BONNET, ADAPTER	-	1
4	HEX, CAP SCREWS OR STUDS	-	8
5	NUTS	-	8
6	COMPRESSOR, F/ ELASTOMER DIAPHRAGM	-	1
7	PIN, SPIRAL	STN. STL.	1
8	FITTING, LUBE #1744-B	-	1
9	SPINDLE, VALVE	STN. STL.	1
10	O-RING #326	BLMA-N	1
11	NUT, ADAPTER BUSHING	DI.	1
12	O-RING "SEE CHART"	BLMA-N	1
13	COVER, LOWER	ALUMINUM	1
14	DIAPHRAGM, AIR MOTOR	BLMA-N	1
15	COVER, UPPER	ALUMINUM	1
16	PLATE, ACTUATOR	CI.	2
17	NUT, HEX JAM	C.STL.	1
18	SCREW, HEX HD. CAP	C.STL.	9
19	NUT, HEX	C.STL.	9
20	GASKET	BLMA-N	2
21	SEAT, SPRING	DI.	2
22	ROD, SPRING	C.STL.	1
23	SPRING	STEEL	1
24	BUSHING, ADJUSTING	DI.	1
25	NUT, HEX	STEEL	4
26	WASHER, SPRINGLOCK	STEEL	4
27	COVER, SPRING	CI.	1
28	COLUMN	C.STL.	4
29	HOUSING, SPRING	C.STL.	1

Dimensional Data

Series 3150 Direct Acting

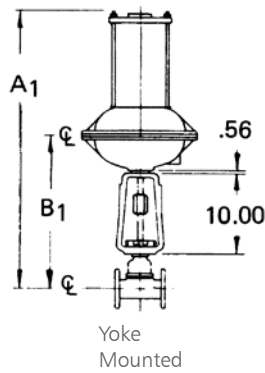
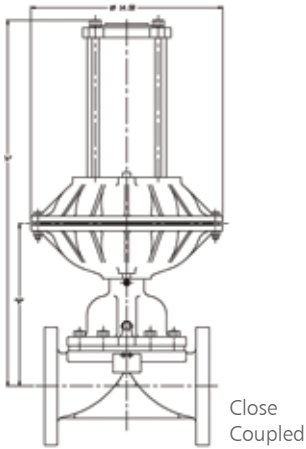

LIMIT SWITCHES	H	J	K	L
BZE6-2RN or DTE6-2RN	7.44	7.44	7.44	7.44
BAF1-2RN-RH or DTF2-2RN-RH	7.69	8.00	8.00	7.69
EX-Q or EXD-Q	8.38	9.19	9.19	8.38

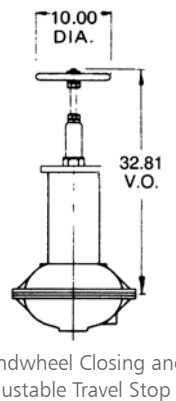
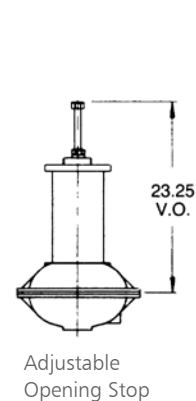
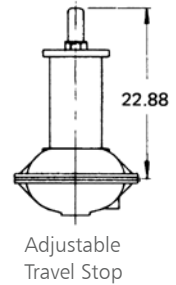
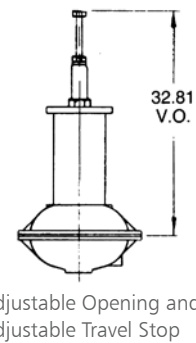
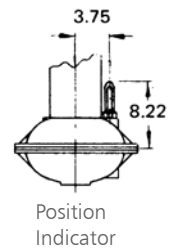
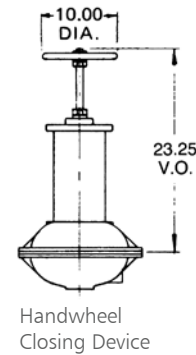
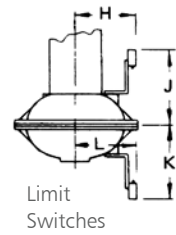
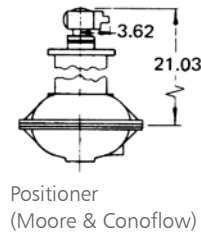

Weir Valves					
Valve Size	Close Coupled		Yoke Mounted		Ends
	A	B	A1	B1	
1 ¼ – 1 ½	24.68	9.26	35.24	19.83	Screwed
	24.49	9.07	35.05	19.64	Flanged
2	25.17	9.74	35.73	20.31	Screwed
	25.04	9.61	35.60	20.18	Flanged
2 ½	26.17	10.77	36.73	21.34	Screwed
	25.98	10.58	36.54	21.15	Flanged
3	26.72	11.31	37.28	21.88	Screwed
	26.54	11.13	37.10	21.70	Flanged
4	27.89	12.47	38.45	23.04	Flanged
6	31.35	15.93	41.91	26.50	Flanged

Straightway Valves					
Valve Size	Close Coupled		Yoke Mounted		Ends
	A	B	A1	B1	
1	23.88	8.45	34.44	19.02	Flanged
1 ½	24.78	9.28	35.34	19.84	Flanged
2	25.82	10.32	36.38	20.88	Flanged
2 ½	26.99	11.49	37.55	22.05	Flanged
3	26.81	11.31	37.37	21.87	Flanged

Dualrange Valves					
Valve Size	Close Coupled		Yoke Mounted		Ends
	A	B	A1	B1	
1 ½	26.97	11.47	37.53	22.03	Screwed
	26.78	11.28	37.34	21.84	Flanged
2	27.08	11.58	37.64	22.14	Screwed
	26.95	11.45	37.51	22.01	Flanged
2 ½	28.20	12.70	38.76	23.26	Screwed
	28.01	12.51	38.57	23.07	Flanged
3	29.38	13.88	39.94	24.44	Screwed
	29.20	13.70	39.76	24.26	Flanged
4	30.74	15.24	41.30	25.80	Flanged

Bill of Materials

Series 3251-3256 Reverse Acting

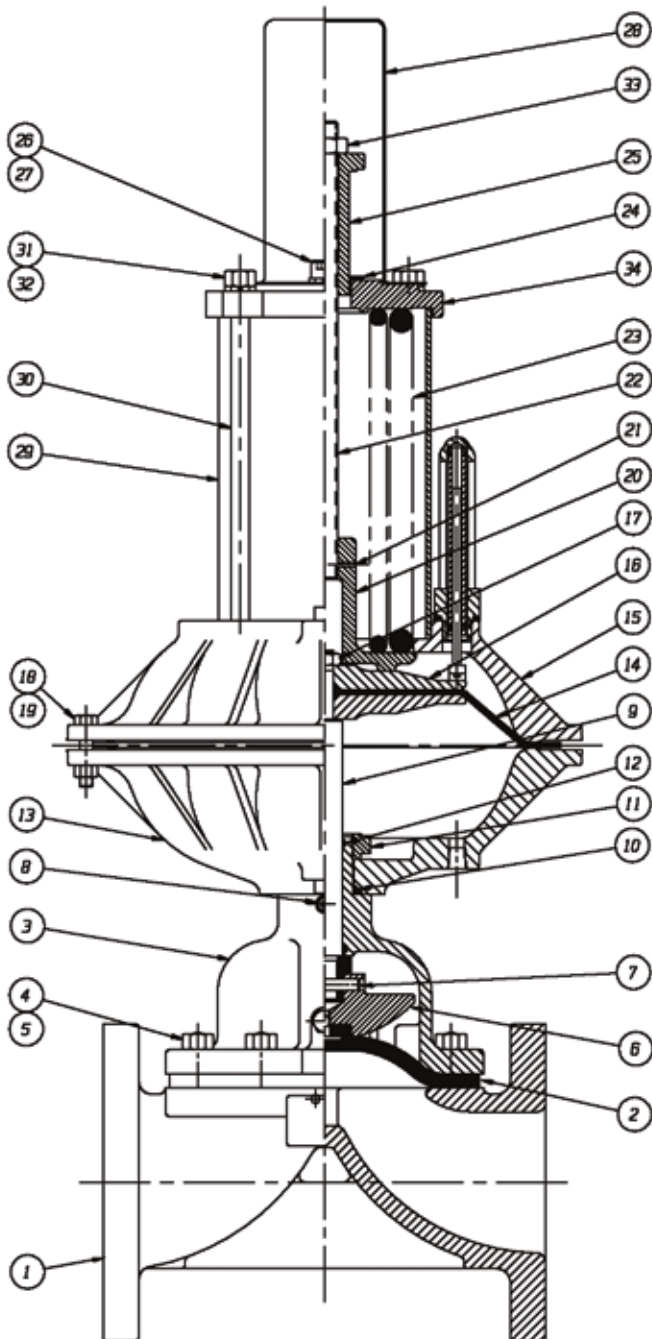

LIST OF PARTS			
ITEM	DESCRIPTION	MATERIAL	QTY.
1	BODY, FLANGED FLAT FACE	-	1
2	DIAPHRAGM, ELASTOMER	-	1
3	BONNET, ADAPTER	-	1
4	HEX. CAP SCREWS OR STUDS	-	8
5	NUTS	-	8
6	COMPRESSOR, F/ ELASTOMER DIAPHRAGM	-	1
7	PIN, SPIROL	STN. STL.	1
8	FITTING, LUBE #1744-B	-	1
9	SPINDLE, VALVE	STN. STL.	1
10	D-RING #326	BLINA-N	1
11	NUT, ADAPTER BUSHING	DI.	1
12	D-RING 'SEE CHART'	BLINA-N	1
13	COVER, LOWER	ALUMINUM	1
14	DIAPHRAGM, AIR MOTOR	BLINA-N	1
15	COVER, UPPER	ALUMINUM	1
16	PLATE, ACTUATOR	CI.	2
17	NUT, HEX JAH	C.STL.	1
18	SCREW, HEX HD. CAP	C.STL.	9
19	NUT, HEX	C.STL.	9
20	SEAT, SPRING	CI.	1
21	PIN, SPIROL (SPRING SEAT)	STN. STL.	1
22	ROD, SPRING	C.STL.	1
23	SPRING	STEEL	AR
24	WASHER, THRUST	C.STL.	1
25	BUSHING, ADJUSTING	DI.	1
26	SCREW, HEX HD CAP	C.STL.	2
27	WASHER, SPRINGLOCK	C.STL.	2
28	SHIELD, TRAVEL STOP	C.STL.	4
29	HOUSING, SPRING	C.STL.	2
30	COLUMN	C.STL.	4
31	NUT, HEX	C.STL.	4
32	WASHER, SPRINGLOCK	C.STL.	4
33	NUT, HEX JAH	C.STL.	1
34	COVER, SPRING	CI.	1

Dimensional Data

Series 3251, 3252 and 3256 Reverse Acting (Standard)

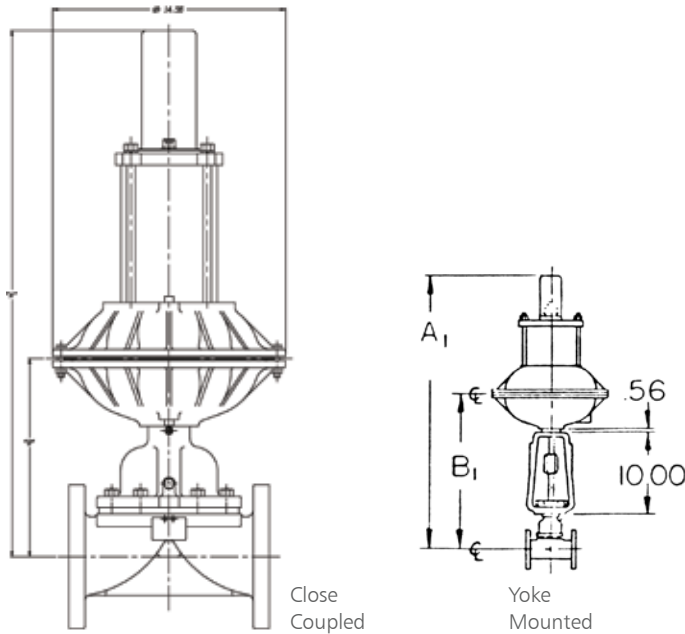

LIMIT SWITCHES	H	J	K	L
BZE6-2RN or DTE6-2RN	7.44	7.44	7.44	7.44
BAF1-2RN-RH or DTF2-2RN-RH	7.69	8.00	8.00	7.69
EX-Q or EXD-Q	8.38	9.19	9.19	8.38

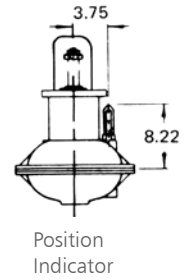
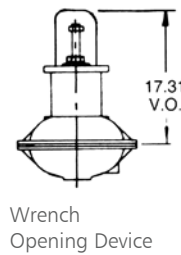
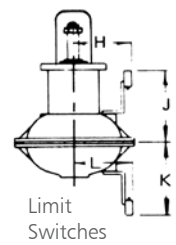
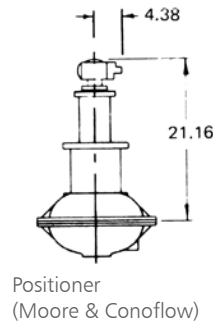

Weir Valves					
Valve Size	Close Coupled		Yoke Mounted		Ends
	A	B	A1	B1	
1	24.91	7.72	35.48	18.29	Screwed
	24.72	7.53	35.29	18.10	Flanged
1 ¼ – 1 ½	26.49	9.26	37.05	19.83	Screwed
	26.30	9.07	36.86	19.64	Flanged
2	26.98	9.74	37.54	20.31	Screwed
	26.85	9.61	37.41	20.18	Flanged
2 ½	27.98	10.77	38.54	21.34	Screwed
	27.79	10.58	38.35	21.15	Flanged
3	28.53	11.31	39.09	21.88	Screwed
	28.35	11.13	38.91	21.70	Flanged

Straightway Valves					
Valve Size	Close Coupled		Yoke Mounted		Ends
	A	B	A1	B1	
1	25.64	8.45	36.21	19.02	Flanged

Dualrange Valves					
Valve Size	Close Coupled		Yoke Mounted		Ends
	A	B	A1	B1	
1 ½	28.78	11.47	39.34	22.03	Screwed
	28.59	11.28	39.15	21.84	Flanged
2	28.89	11.58	39.45	22.14	Screwed
	28.76	11.45	39.32	22.01	Flanged

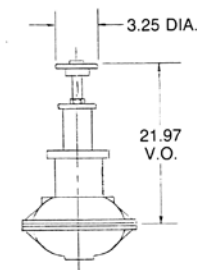

Adjustable Opening Stop
with Handwheel

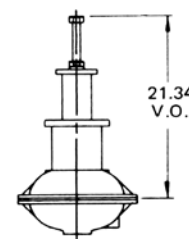

Adjustable
Opening Stop

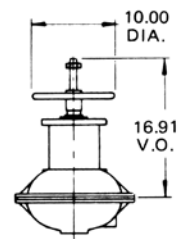

Handwheel
Opening Device

Dimensional Data

Series 3253, 3254, 3255 Reverse Acting (Large)

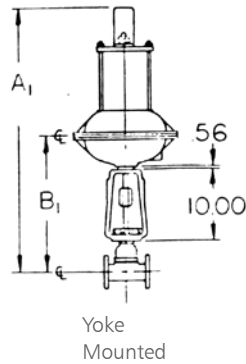
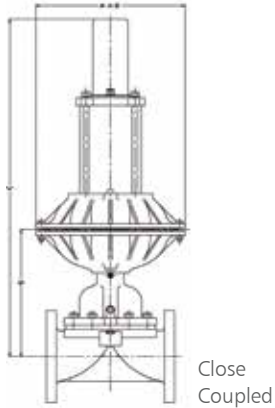

LIMIT SWITCHES	H	J	K	L
BZE6-2RN or DTE6-2RN	7.44	7.44	7.44	7.44
BAF1-2RN-RH or DTF2-2RN-RH	7.69	8.00	8.00	7.69
EX-Q or EXD-Q	8.38	9.19	9.19	8.38

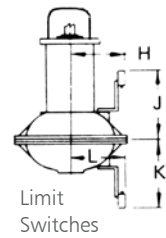
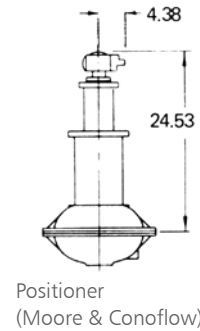

Weir Valves					
Valve Size	Close Coupled		Yoke Mounted		Ends
	A	B	A1	B1	
1 ¼ –	29.86	9.26	40.42	19.83	Screwed
1 ½	29.67	9.07	40.23	19.64	Flanged
2	30.35	9.74	40.91	20.31	Screwed
	30.22	9.61	40.78	20.18	Flanged
2 ½	31.35	10.77	41.91	21.34	Screwed
	31.16	10.58	41.72	21.15	Flanged
3	31.90	11.31	42.45	21.88	Screwed
	31.72	11.13	42.28	21.70	Flanged
4	33.07	12.47	43.63	23.04	Flanged
6	36.53	15.93	47.09	26.50	Flanged

Straightway Valves					
Valve Size	Close Coupled		Yoke Mounted		Ends
	A	B	A1	B1	
1	29.06	8.45	39.62	19.02	Flanged
1 ½	29.26	9.28	40.52	19.84	Flanged
2	31.00	10.32	41.56	20.88	Flanged
2 ½	32.17	11.49	42.73	22.05	Flanged
3	31.99	11.31	42.55	21.87	Flanged

Dualrange Valves					
Valve Size	Close Coupled		Yoke Mounted		Ends
	A	B	A1	B1	
1 ½	32.15	11.47	42.71	22.03	Screwed
	31.96	11.28	42.52	21.84	Flanged
2	32.26	11.58	42.82	22.14	Screwed
	32.13	11.45	42.69	22.01	Flanged
2 ½	33.38	12.70	43.94	23.26	Screwed
	33.19	12.51	43.75	23.07	Flanged
3	34.56	13.88	45.12	24.44	Screwed
	34.38	13.70	44.94	24.26	Flanged

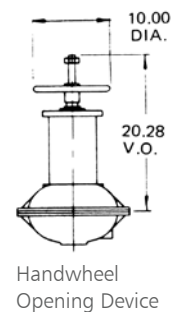
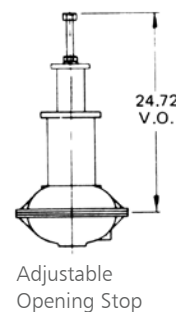
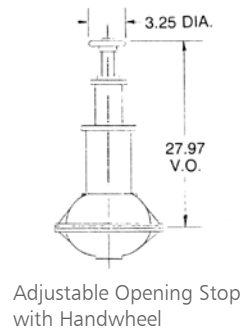
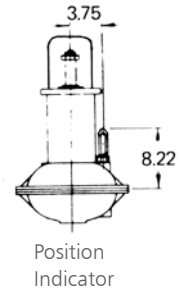
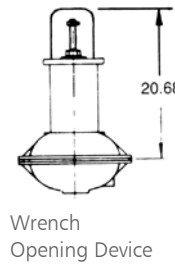

Bill of Materials

Series 3375 Double Acting

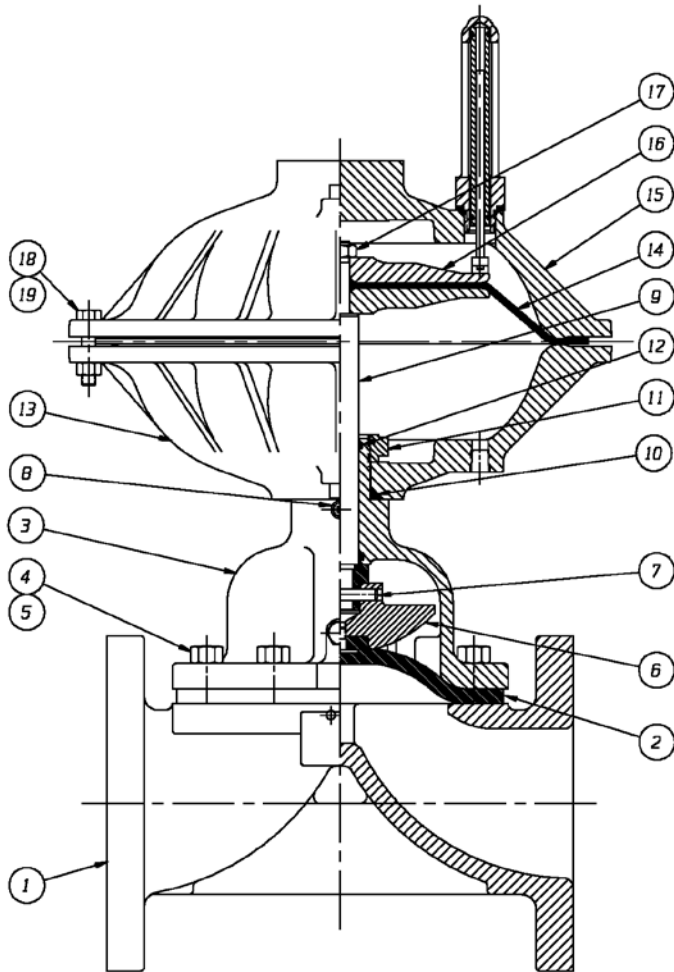

LIST OF PARTS			
ITEM	DESCRIPTION	MATERIAL	QTY.
1	BODY, FLANGED	-	1
2	DIAPHRAGM, ELASTOMER	-	1
3	BONNET, ADAPTER	-	1
4	HEX, CAP SCREWS OR STUDS	-	4
5	NUTS	-	4
6	COMPRESSOR, F/ ELASTOMER DIAPHRAGM	-	1
7	PIN, SPIROL	STN. STL.	1
8	FITTING, LUBE	-	1
9	SPINDLE, VALVE	STN. STL.	1
10	O-RING	ELUNA-N	1
11	NUT, ADAPTER BUSHING	O.I.	1
12	O-RING	ELUNA-N	1
13	COVER, LOWER	ALUMINUM	1
14	DIAPHRAGM, AIR MOTOR	ELUNA-N	1
15	COVER, UPPER	ALUMINUM	1
16	PLATE, ACTUATOR	C.I.	2
17	NUT, HEX JAM	CAR. STL.	1
18	SCREW, HEX HD. CAP	CAR. STL.	8
19	NUT, HEX	CAR. STL.	8

Dimensional Data

Series 3375 Double Acting

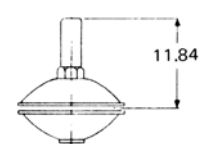
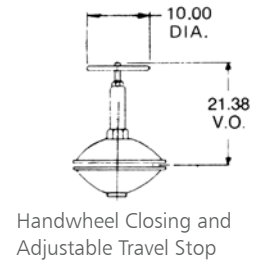
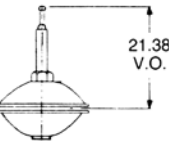
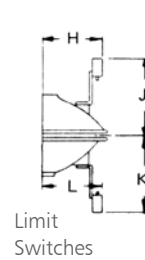
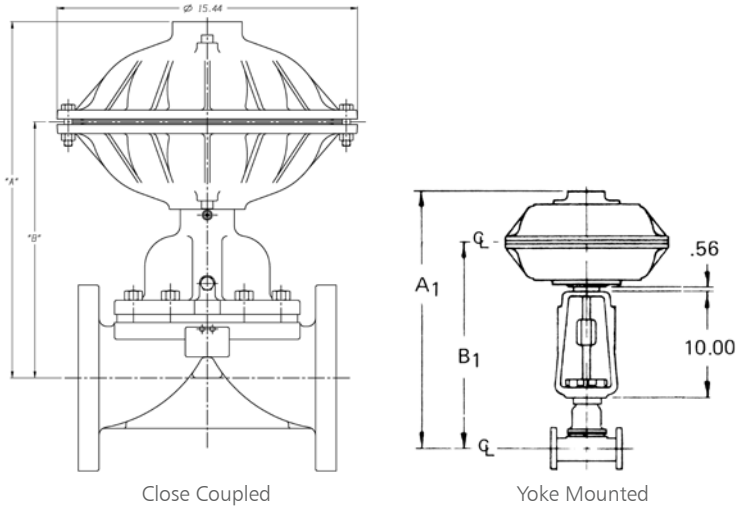

Adjustable Opening and Adjustable Travel Stop

Adjustable Travel Stop

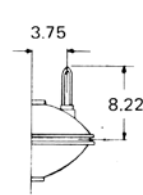

Position Indicator

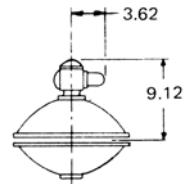

Positioner (Moore & Conoflow)

Weir Valves					
Valve Size	Close Coupled		Yoke Mounted		Ends
	A	B	A1	B1	
1 1/2	14.02	9.26	24.59	19.83	Screwed
	13.83	9.07	24.40	19.64	Flanged
2	14.50	9.74	25.07	20.31	Screwed
	14.37	9.61	24.94	20.18	Flanged
2 1/2	15.53	10.77	26.10	21.34	Screwed
	15.34	10.58	25.91	21.15	Flanged
3	16.06	11.30	26.63	21.87	Screwed
	15.88	11.12	26.45	21.69	Flanged
4	17.22	12.46	27.79	23.03	Flanged
6	20.68	15.92	31.25	26.49	Flanged

Straightway Valves					
Valve Size	Close Coupled		Yoke Mounted		Ends
	A	B	A1	B1	
2	15.08	10.31	25.65	20.88	Flanged
2 1/2	16.26	11.49	26.83	22.06	Flanged
3	16.08	11.31	26.65	21.88	Flanged
4	17.56	12.79	28.13	23.36	Flanged
6	20.31	15.74	31.08	26.31	Flanged

Dualrange Valves					
Valve Size	Close Coupled		Yoke Mounted		Ends
	A	B	A1	B1	
2 1/2	17.45	12.70	28.01	23.26	Screwed
	17.26	12.51	27.82	23.07	Flanged
3	18.63	13.88	29.19	24.44	Screwed
	18.45	13.70	29.01	24.26	Flanged
4	19.99	15.24	30.55	25.80	Flanged
6	23.72	18.97	34.28	29.53	Flanged

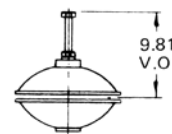

Adjustable Opening Stop

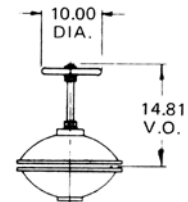

Handwheel Closing Device

Bill of Materials

Series 3274-79 Reverse Acting

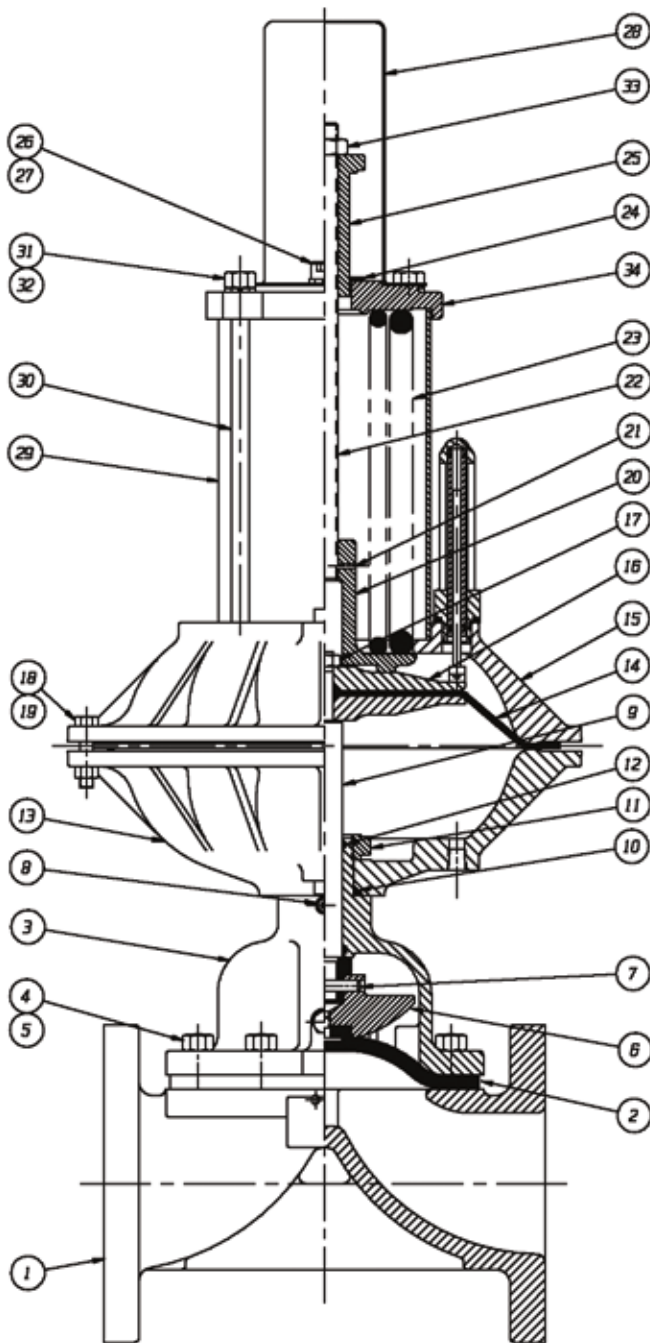

LIST OF PARTS			
ITEM	DESCRIPTION	MATERIAL	QTY.
1	BODY, FLANGED FLAT FACE	-	1
2	DIAPHRAGM, ELASTOMER	-	1
3	BONNET, ADAPTER	-	1
4	HEX, CAP SCREWS OR STUDS	-	8
5	NUTS	-	8
6	COMPRESSOR, F/ ELASTOMER DIAPHRAGM	-	1
7	PIN, SPIRAL	STN. STL.	1
8	FITTING, LUBE #1744-B	-	1
9	SPINDLE, VALVE	STN. STL.	1
10	D-RING #326	BLUNA-N	1
11	NUT, ADAPTER BUSHING	DI.	1
12	D-RING 'SEE CHART'	BLUNA-N	1
13	COVER, LOWER	ALUMINUM	1
14	DIAPHRAGM, AIR MOTOR	BLUNA-N	1
15	COVER, UPPER	ALUMINUM	1
16	PLATE, ACTUATOR	CI.	2
17	NUT, HEX JAM	C.STL.	1
18	SCREW, HEX HD. CAP	C.STL.	9
19	NUT, HEX	C.STL.	9
20	SEAT, SPRING	CI.	1
21	PIN, SPIRAL (SPRING SEAT)	STN. STL.	1
22	ROD, SPRING	C.STL.	1
23	SPRING	STEEL	AR
24	WASHER, THRUST	C.STL.	1
25	BUSHING, ADJUSTING	DI.	1
26	SCREW, HEX HD CAP	C.STL.	2
27	WASHER, SPRINGLOCK	C.STL.	2
28	SHIELD, TRAVEL STOP	C.STL.	4
29	HOLDS, SPRING	C.STL.	2
30	COLUMN	C.STL.	8
31	NUT, HEX	C.STL.	8
32	WASHER, SPRINGLOCK	C.STL.	8
33	NUT, HEX JAM	C.STL.	1
34	COVER, SPRING	CI.	1

Dimensional Data

Series 3274-79 Reverse Acting

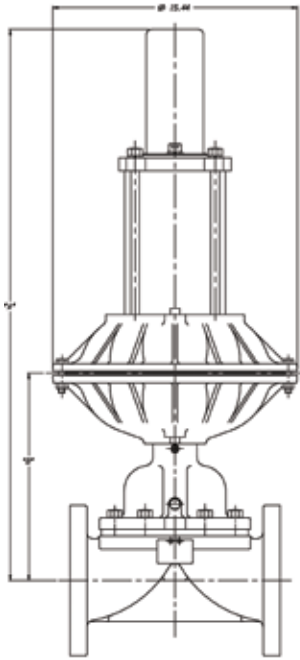

Close Coupled

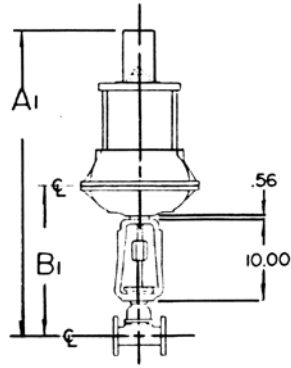

Yoke Mounted

MICRO SWITCH	H	J	K	L
BZE6-2RN OR DTE6-2RN	8.75	8.41	7.44	7.44
BAF1-2RN OR DTF2-2RN-RH	9.00	8.97	8.00	7.69
EX-Q OR EXD-Q	9.69	10.16	9.19	8.38

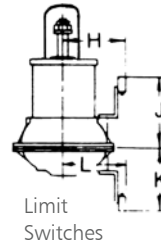

Limit Switches

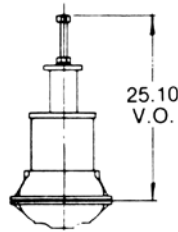

Adjustable Opening Stop

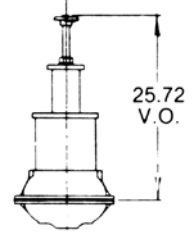

Adjustable Opening Stop with Handwheel

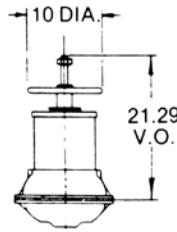

Handwheel Opening Device

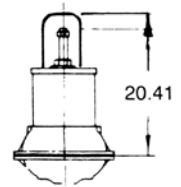

Wrench Opening Device

Weir Valves					
Valve Size	Close Coupled		Yoke Mounted		Ends
	A	B	A1	B1	
2 1/2	31.19	10.77	41.76	21.34	Screwed
	31.00	10.58	41.57	21.15	Flanged
3	31.72	11.30	42.29	21.87	Screwed
	31.54	11.12	42.11	21.69	Flanged
4	32.88	12.46	43.45	23.03	Flanged
6	36.34	15.92	46.91	26.49	Flanged

Straightway Valves					
Valve Size	Close Coupled		Yoke Mounted		Ends
	A	B	A1	B1	
2 1/2	31.90	11.49	42.46	22.05	Flanged
3	31.72	11.31	42.28	21.87	Flanged
4	33.22	12.81	43.78	23.37	Flanged

Dualrange Valves					
Valve Size	Close Coupled		Yoke Mounted		Ends
	A	B	A1	B1	
2 1/2	33.11	12.70	43.67	23.26	Screwed
	32.92	12.51	43.48	23.07	Flanged
3	34.29	13.88	44.85	24.44	Screwed
	34.11	13.70	44.67	24.26	Flanged
4	35.65	15.24	46.21	25.80	Flanged

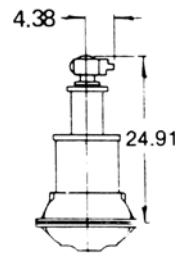

Positioner (Moore & Conoflow)

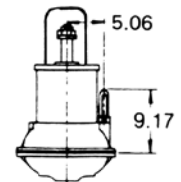

Position Indicator

Bill of Materials

Series 33101 Double Acting

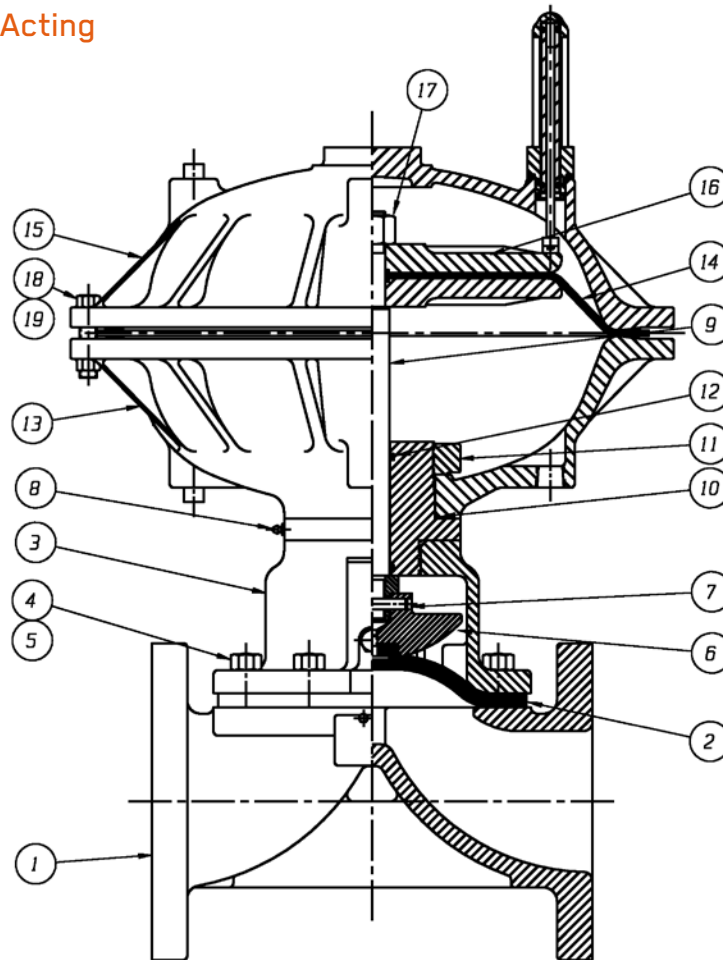

LIST OF PARTS			
ITEM	DESCRIPTION	MATERIAL	QTY.
1	BODY, FLANGED	-	1
2	DIAPHRAGM, ELASTOMER	-	1
3	BONNET, ADAPTER	-	1
4	HEX, CAP SCREWS OR STUDS	-	AR
5	NUTS	-	AR
6	COMPRESSOR, F/ ELASTOMER DIAPHRAGM	CI	1
7	PIN, SPIROL	STN STL	1
8	FITTING, LUBE	-	1
9	SPINDLE, VALVE	STN STL	1
10	O-RING	BUNA-N	1
11	NUT, ADAPTER BUSHING	DI	1
12	O-RING	BUNA-N	1
13	COVER, LOWER	ALLUMINUM	1
14	DIAPHRAGM, AIR MOTOR	BUNA-N	1
15	COVER, UPPER	ALLUMINUM	1
16	PLATE, ACTUATOR	DI	2
17	NUT, HEAVY HEX.	C.STL	1
18	SCREW, HEX HD. CAP	C.STL	24
19	NUT, HEX	C.STL	24

Dimensional Data

Series 33101 Double Acting

LIMIT SWITCHES	G&K	H&J
BZE6-2RN or DTE6-2RN	8.69	8.38
BAF1-2RN-RH or DTF2-2RN-RH	9.00	8.94
EX-Q or EXD-Q	9.68	10.06

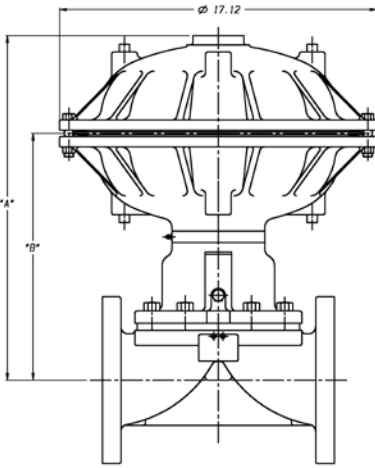

Close Coupled

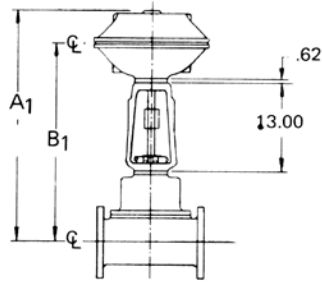

Yoke Mounted

Weir Valves					
Valve Size	Close Coupled		Yoke Mounted		Ends
	A	B	A1	B1	
2 1/2	16.52	11.25	30.14	24.87	Screwed
	16.33	11.06	29.95	24.68	Flanged
3	17.41	12.14	31.03	25.76	Screwed
	17.23	11.96	30.85	25.58	Flanged
4	18.58	13.31	32.20	26.93	Flanged
6	21.26	15.99	34.88	29.61	Flanged
8	25.13	19.86	38.75	33.48	Flanged

Straightway Valves					
Valve Size	Close Coupled		Yoke Mounted		Ends
	A	B	A1	B1	
2 1/2	17.78	12.51	31.40	26.13	Flanged
3	17.75	12.48	31.37	26.10	Flanged
4	18.78	13.51	32.40	27.13	Flanged
6	22.06	16.79	35.68	30.41	Flanged

Dualrange Valves					
Valve Size	Close Coupled		Yoke Mounted		Ends
	A	B	A1	B1	
2 1/2	19.08	13.81	32.70	27.43	Screwed
	18.89	13.62	32.51	27.24	Flanged
3	20.26	14.99	33.88	28.61	Screwed
	20.08	14.81	33.70	28.43	Flanged
4	21.62	16.35	35.24	29.97	Flanged
6	25.35	20.08	38.97	33.70	Flanged

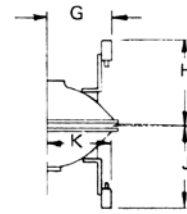

Limit Switches

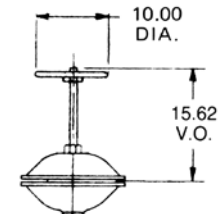

Handwheel Closing Device

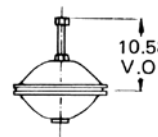

Adjustable Opening Stop

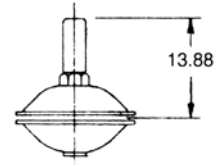

Adjustable Travel Stop

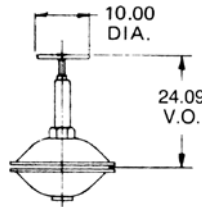

Handwheel Closing, Adjustable Opening, Adjustable Travel Stop

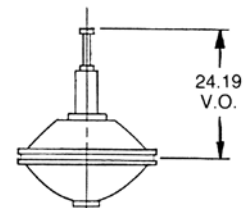

Adjustable Travel Stop and Adjustable Opening Stop

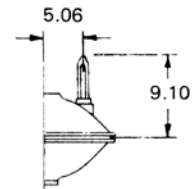

Position Indicator

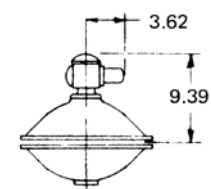

Positioner (Moore & Conoflow)

Bill of Materials

Series 31101 Direct Acting

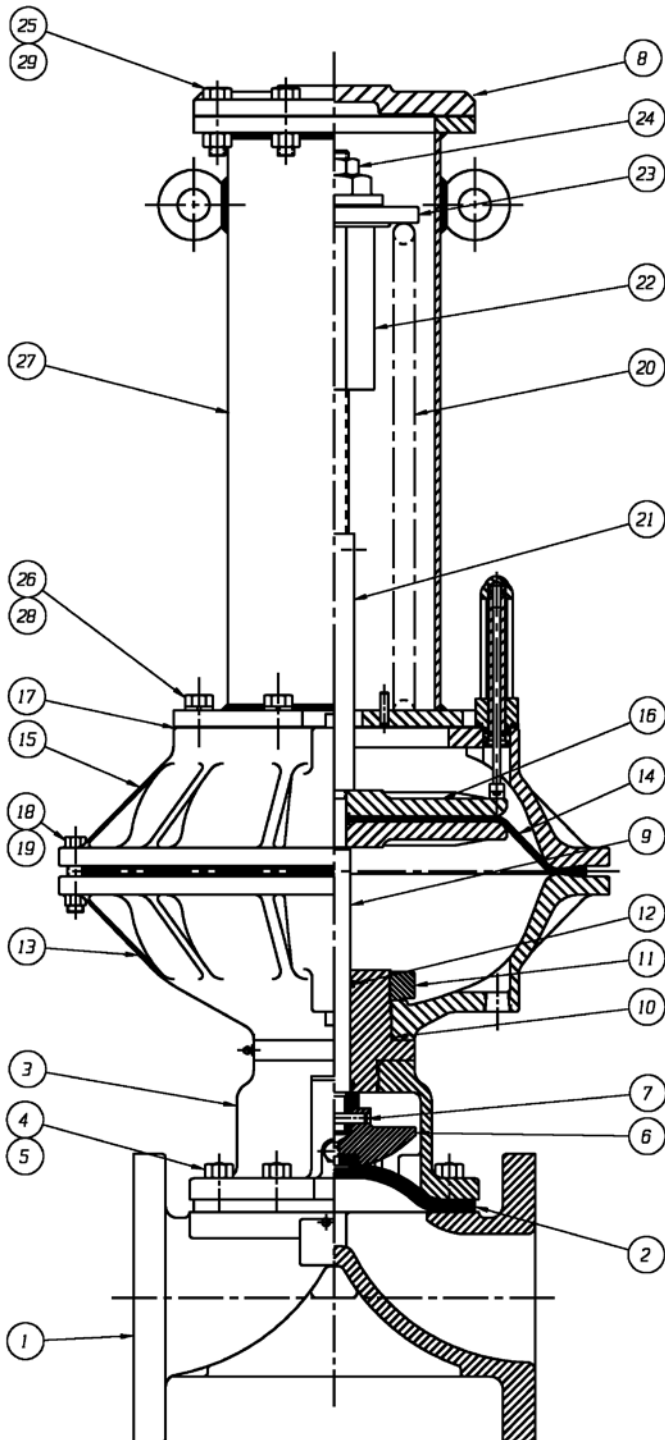

LIST OF PARTS			
ITEM	DESCRIPTION	MATERIAL	QTY.
1	BODY, FLANGED	-	1
2	DIAPHRAGM, ELASTOMER	-	1
3	BONNET, ADAPTER	-	1
4	HEX, CAP SCREWS OR STUDS	-	SEE CHARTS
5	NUTS	-	SEE CHARTS
6	COMPRESSOR, F/ ELASTOMER DIAPHRAGM	CI	1
7	PIN, SPIROL	STN.STL.	1
8	CAP	DI	1
9	SPINDLE, VALVE	STN STL	1
10	O-RING #23B	BUNA-N	1
11	NUT, ADAPTER BUSHING	DI	1
12	O-RING #214	BUNA-N	1
13	COVER, LOWER	ALUMINUM	1
14	DIAPHRAGM, AIR MOTOR	BUNA-N	1
15	COVER, UPPER	ALUMINUM	1
16	PLATE, ACTUATOR	DI	2
17	GASKET	SILICONE	1
18	SCREW, HEX HD. CAP	C.STL	24
19	NUT, HEX	C.STL	24
20	SPRING	C.STL	1
21	SPINDLE EXTENSION ASSEMBLY	-	1
22	BUSHING, ADJUSTING	DI	1
23	PLATE, SPRING	C.STL	1
24	NUT, HEX JAM	C.STL	1
25	SCREW, HEX HD CAP	C.STL	8
26	WASHER, SPRINGLOCK	C.STL	8
27	ASSEMBLY SPRING CASING	C.STL	1
28	SCREW, HEX HD CAP	C.STL	8
29	NUT, HEX	C.STL	8

Dimensional Data

Series 31101 Direct Acting

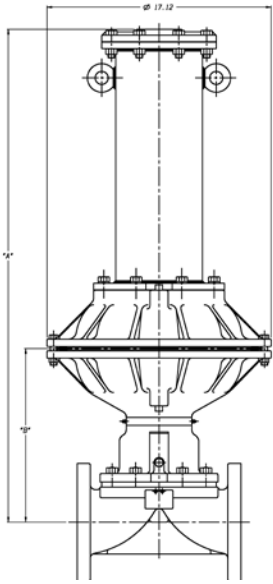

Close Coupled

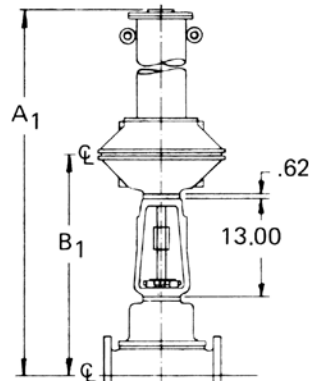

Yoke Mounted

LIMIT SWITCHES	G&K	H&J
BZE6-2RN or DTE6-2RN	8.69	8.38
BAF1-2RN-RH or DTF2-2RN-RH	9.00	8.94
EX-Q or EXD-Q	9.68	10.06

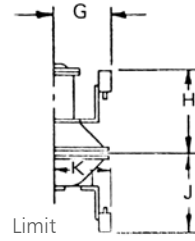

Limit Switches

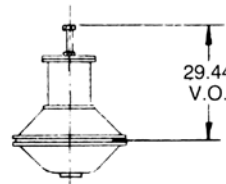

Adjustable Opening Stop

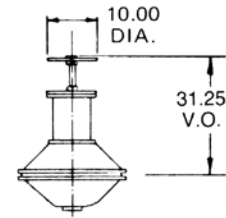

Handwheel Closing

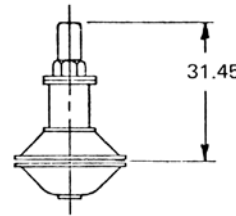

Adjustable Travel Stops

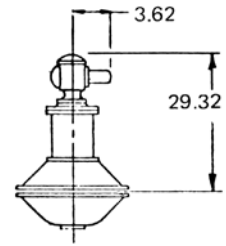

Positioner (Moore & Conoflow)

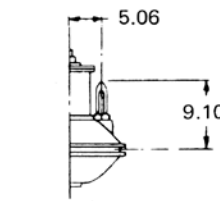

Position Indicator

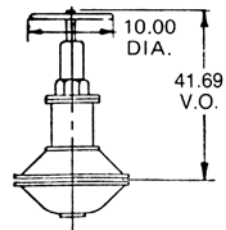

Handwheel Closing Device with Adjustable Travel Adjustable Open Stop

Weir Valves

Valve Size	Close Coupled		Yoke Mounted		Ends
	A	B	A1	B1	
2 1/2	35.14	11.25	48.76	24.87	Screwed
	34.95	11.06	48.57	24.68	Flanged
3	36.03	12.14	49.65	25.76	Screwed
	35.85	11.96	49.47	25.58	Flanged
4	37.20	13.31	50.82	26.93	Flanged
6	39.88	15.99	53.50	29.61	Flanged
8	43.75	19.86	57.37	33.48	Flanged

Straightway Valves

Valve Size	Close Coupled		Yoke Mounted		Ends
	A	B	A1	B1	
2 1/2	36.40	12.51	50.02	26.13	Flanged
3	36.37	12.48	49.99	26.10	Flanged
4	37.40	13.51	51.02	27.13	Flanged
6	40.68	16.79	54.30	30.41	Flanged

Dualrange Valves

Valve Size	Close Coupled		Yoke Mounted		Ends
	A	B	A1	B1	
2 1/2	37.70	13.81	51.32	27.43	Screwed
	37.51	13.62	51.13	27.24	Flanged
3	38.88	14.99	52.50	28.61	Screwed
	38.70	14.81	52.32	28.43	Flanged
4	40.24	16.35	53.86	29.97	Flanged
6	43.97	20.08	57.59	33.70	Flanged

Bill of Materials

Series 32102-107 and 109 Reverse Acting

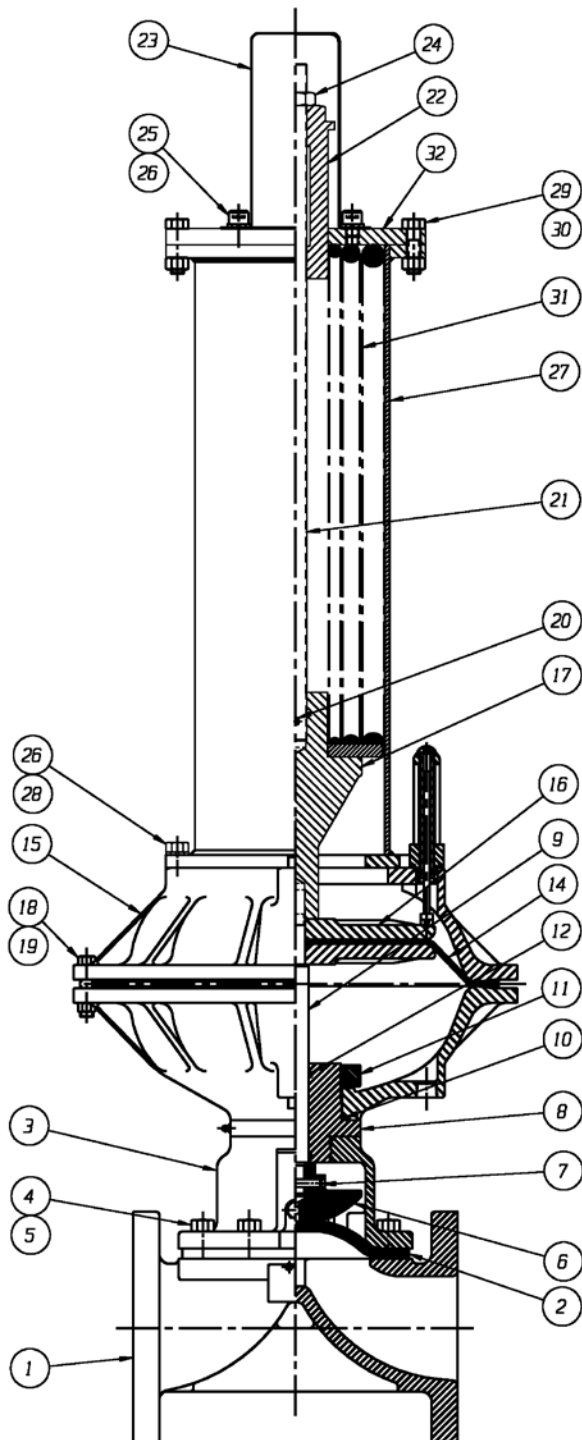

LIST OF PARTS			
ITEM	DESCRIPTION	MATERIAL	QTY.
1	BODY, FLANGED	-	1
2	DIAPHRAGM	-	1
3	BONNET, ADAPTER	-	1
4	HEX, CAP SCREWS OR STUDS	-	AR
5	NUTS	-	AR
6	COMPRESSOR, F/ ELASTOMER DIAPHRAGM	CI	1
7	PIN, SPIROL	STN STL	1
8	BUSHING, ADAPTER	DI	1
9	SPINDLE, VALVE	STN STL	1
10	O-RING #238	BLNA-N	1
11	NUT, ADAPTER BUSHING	DI	1
12	O-RING	BLNA-N	1
13	COVER, LOWER	ALUMINUM	1
14	DIAPHRAGM, AIR MOTOR	BLNA-N	1
15	COVER, UPPER	ALUMINUM	1
16	PLATE, ACTUATOR	DI	2
17	CONNECTOR, SPINDLE	DI	1
18	SCREW, HEX HD. CAP	C STL	24
19	NUT, HEX	C STL	24
20	PIN, SPIROL	STN STL	1
21	EXTENSION, SPINDLE	C STL	1
22	BUSHING, ADJUSTING	DI	1
23	SHIELD, TRAVEL STOP	C STL	1
24	NUT, HEX JAM	C STL	1
25	SCREW, HEX SOC HD CAP	C STL	2
26	WASHER, SPRINGLOCK	C STL	10
27	ASSEMBLY, SPRING CASING	C STL	1
28	SCREW, HEX HD CAP	C STL	8
29	SCREW, HEX HD CAP	C STL	8
30	NUT, HEX	C STL	8
31	SPRING	C STL	AR
32	COVER, SPRING CASE	C STL	1

Dimensional Data

Series 32102-107 and 109 Reverse Acting

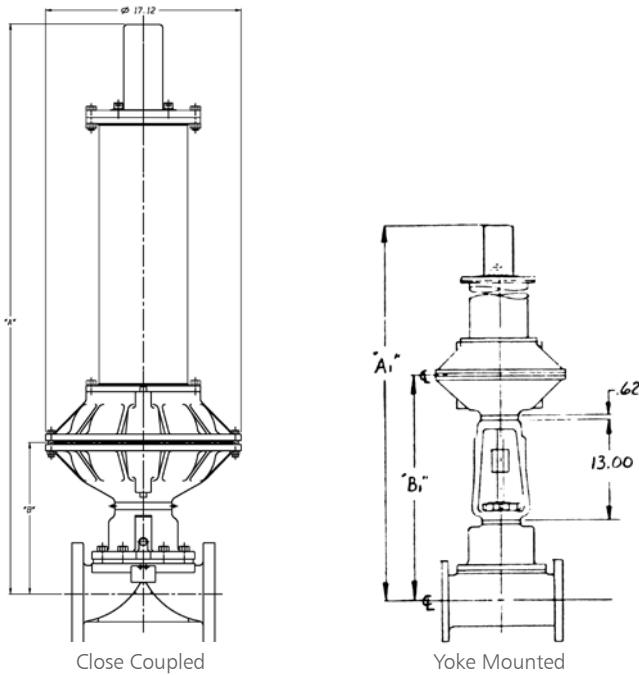

LIMIT SWITCHES	G&K	H&J
BZE6-2RN or DTE6-2RN	8.69	8.38
BAF1-2RN-RH or DTF2-2RN-RH	9.00	8.94
EX-Q or EXD-Q	9.68	10.06

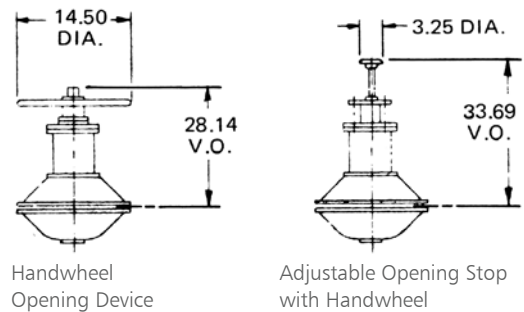
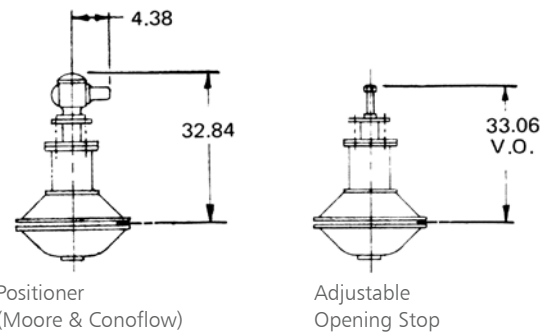
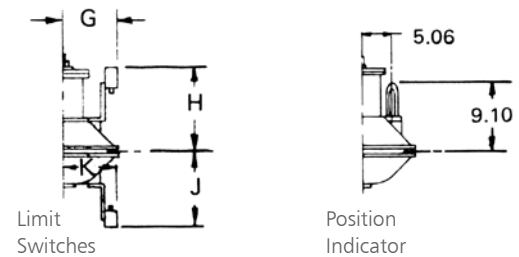

Weir Valves					
Valve Size	Close Coupled		Yoke Mounted		Ends
	A	B	A1	B1	
2 1/2	38.18	11.25	51.80	24.87	Screwed
	37.99	11.06	51.61	24.68	Flanged
3	39.07	12.14	52.69	25.76	Screwed
	38.89	11.96	52.51	25.58	Flanged
4	31.24	13.31	53.86	26.93	Flanged
6	42.92	15.99	56.54	29.61	Flanged
8	46.79	19.86	60.41	33.48	Flanged

Straightway Valves					
Valve Size	Close Coupled		Yoke Mounted		Ends
	A	B	A1	B1	
2 1/2	39.44	12.51	53.06	26.13	Flanged
3	39.41	12.48	53.03	26.10	Flanged
4	40.44	13.51	54.06	27.13	Flanged

Dualrange Valves					
Valve Size	Close Coupled		Yoke Mounted		Ends
	A	B	A1	B1	
2 1/2	40.74	13.81	54.36	27.43	Screwed
	40.55	13.62	54.17	27.24	Flanged
3	41.92	14.99	55.54	28.61	Screwed
	41.74	14.81	55.36	28.43	Flanged
4	43.28	16.35	56.90	29.97	Flanged

Bill of Materials

Series 32108 Reverse Acting

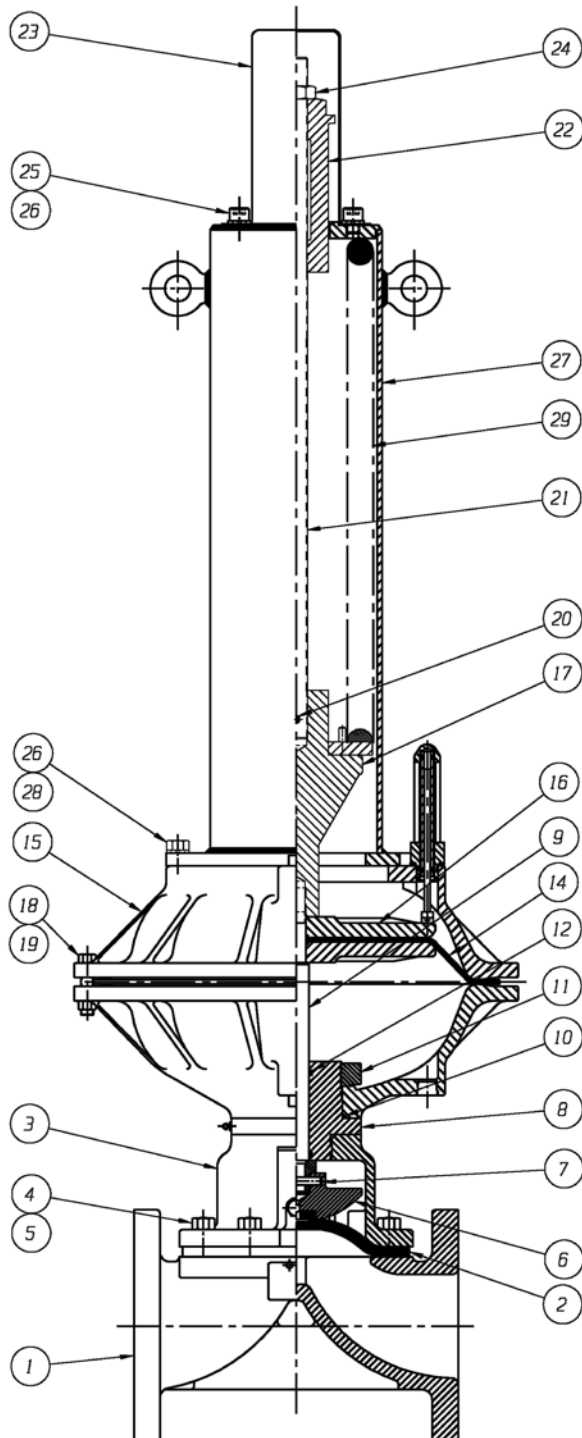

LIST OF PARTS			
ITEM	DESCRIPTION	MATERIAL	QTY.
1	BODY, FLANGED	-	1
2	DIAPHRAGM	-	1
3	BONNET, ADAPTER	-	1
4	HEX, CAP SCREWS OR STUDS	-	AR
5	NUTS	-	AR
6	COMPRESSOR, F/ ELASTOMER DIAPHRAGM	CI	1
7	PIN, SPIROL	STN STL	1
8	BUSHING, ADAPTER	DI	1
9	SPINDLE, VALVE	STN STL	1
10	O-RING #23B	BUNA-N	1
11	NUT, ADAPTER BUSHING	DI	1
12	O-RING	BUNA-N	1
13	COVER, LOWER	ALUMINUM	1
14	DIAPHRAGM, AIR MOTOR	BUNA-N	1
15	COVER, UPPER	ALUMINUM	1
16	PLATE, ACTUATOR	DI	2
17	CONNECTOR, SPINDLE	DI	1
18	SCREW, HEX HD. CAP	C STL	24
19	NUT, HEX	C STL	24
20	PIN, SPIROL	STN STL	1
21	EXTENSION, SPINDLE	C STL	1
22	BUSHING, ADJUSTING	DI	1
23	SHIELD, TRAVEL STOP	C STL	1
24	NUT, HEX JAM	C STL	1
25	SCREW, HEX SDC HD CAP	C STL	2
26	WASHER, SPRINGLOCK	C STL	10
27	ASSEMBLY, SPRING CASING	C STL	1
28	SCREW, HEX HD CAP	C STL	8
29	SPRING, #130	C STL	AR

Dimensional Data

Series 32108 Reverse Acting

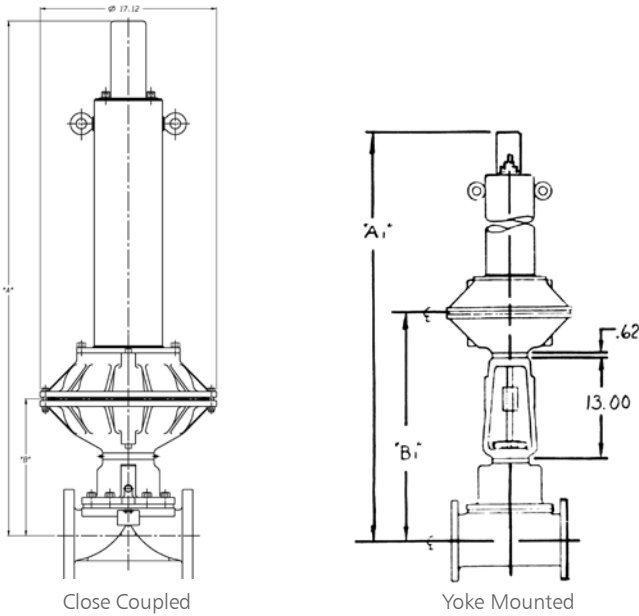

LIMIT SWITCHES	G&K	H&J
BZE6-2RN or DTE6-2RN	8.69	8.38
BAF1-2RN-RH or DTF2-2RN-RH	9.00	8.94
EX-Q or EXD-Q	9.68	10.06

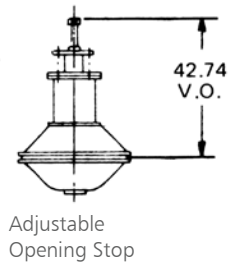
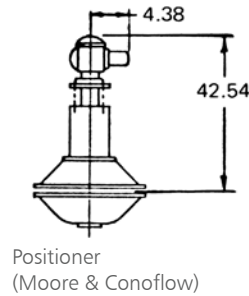
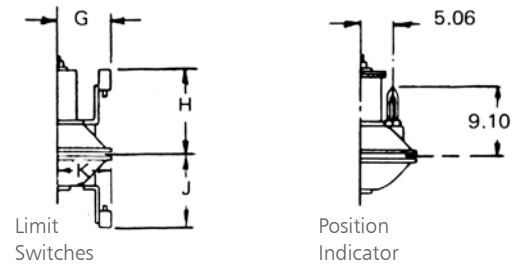

Weir Valves					
Valve Size	Close Coupled		Yoke Mounted		Ends
	A	B	A1	B1	
2 1/2	47.87	11.25	61.49	24.87	Screwed
	47.68	11.06	61.30	24.68	Flanged
3	48.76	12.14	62.38	25.76	Screwed
	48.58	11.96	62.20	25.58	Flanged
4	49.93	13.31	63.55	26.93	Flanged
6	52.61	15.99	66.23	29.61	Flanged
8	56.48	19.86	70.10	33.48	Flanged

Straightway Valves					
Valve Size	Close Coupled		Yoke Mounted		Ends
	A	B	A1	B1	
2 1/2	49.13	12.51	62.75	26.13	Flanged
3	49.10	12.48	62.72	26.10	Flanged
4	50.13	13.51	63.75	27.13	Flanged
6	53.41	16.79	67.03	30.41	Flanged

Dualrange Valves					
Valve Size	Close Coupled		Yoke Mounted		Ends
	A	B	A1	B1	
2 1/2	50.43	13.81	64.05	27.43	Screwed
	50.24	13.62	63.36	27.24	Flanged
3	51.61	14.99	65.23	28.61	Screwed
	51.43	14.81	65.05	28.43	Flanged
4	52.97	16.35	66.59	29.97	Flanged
6	56.70	20.08	70.32	33.70	Flanged

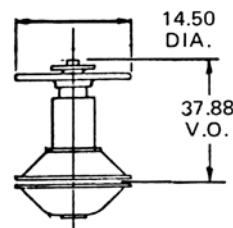

Handwheel Opening Device

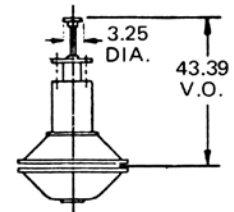

Adjustable Opening Stop with Handwheel

Bill of Materials

Series 33130 Double Acting

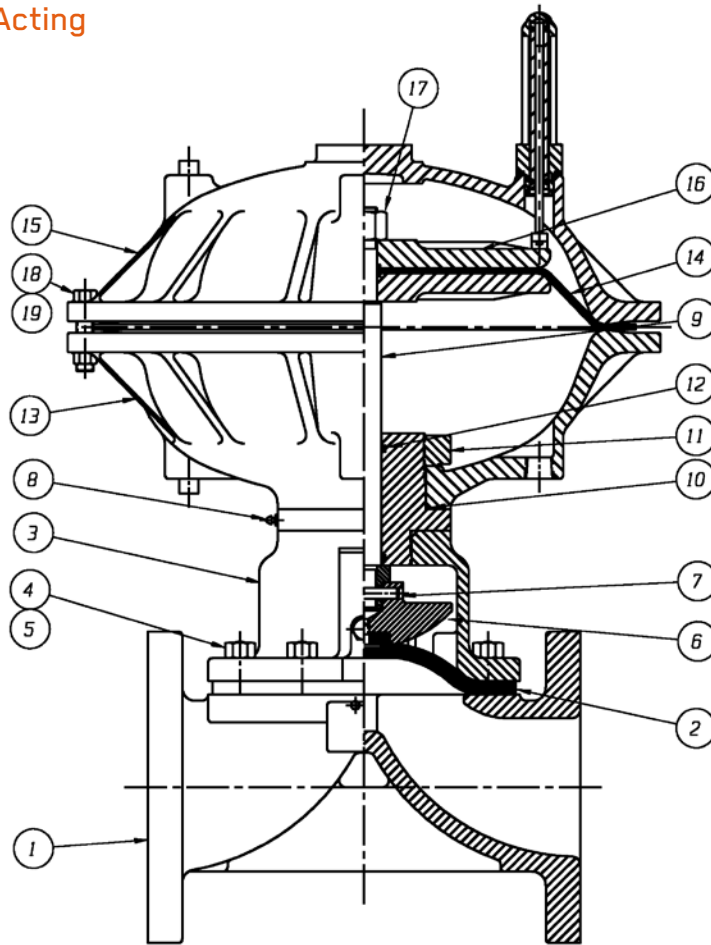

LIST OF PARTS			
ITEM	DESCRIPTION	MATERIAL	QTY.
1	BODY, FLANGED	-	1
2	DIAPHRAGM, ELASTOMER	-	1
3	BONNET, ADAPTER	-	1
4	HEX, CAP SCREWS OR STUDS	-	AR
5	NUTS	-	AR
6	COMPRESSOR, F/ ELASTOMER DIAPHRAGM	CI	1
7	PIN, SPIROL	STN STL	1
8	FITTING, LUBE	-	1
9	SPINDLE, VALVE	STN STL	1
10	O-RING	BUNA-N	1
11	NUT, ADAPTER BUSHING	DI	1
12	O-RING	BUNA-N	1
13	COVER, LOWER	ALUMINUM	1
14	DIAPHRAGM, AIR MOTOR	BUNA-N	1
15	COVER, UPPER	ALUMINUM	1
16	PLATE, ACTUATOR	DI	2
17	NUT, HEAVY HEX.	C.STL	1
18	SCREW, HEX HD. CAP	C.STL	24
19	NUT, HEX	C.STL	24

Dimensional Data

Series 33130 Double Acting

LIMIT SWITCHES	G&K	H&J
BZE6-2RN or DTE6-2RN	9.50	8.44
BAF1-2RN-RH or DTF2-2RN-RH	9.81	9.00
EX-Q or EXD-Q	10.50	10.19

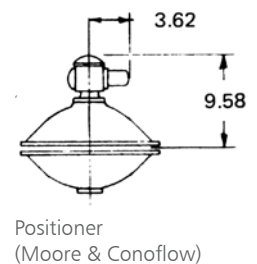
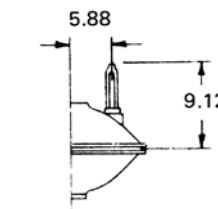
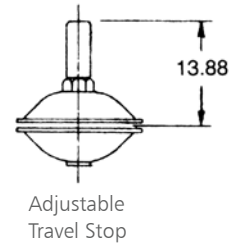
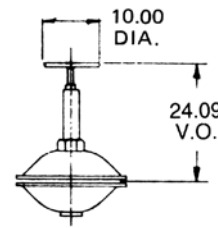
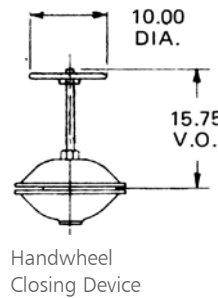
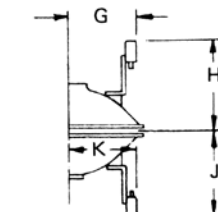
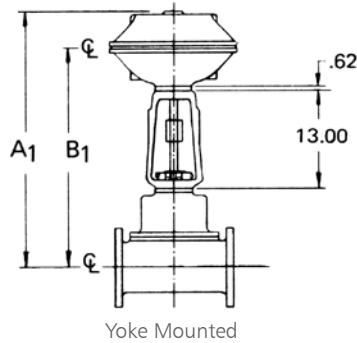
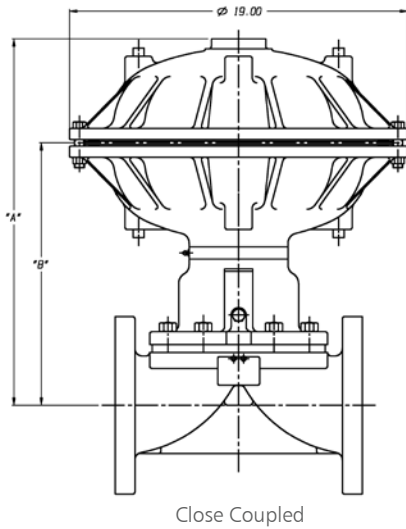

Weir Valves					
Valve Size	Close Coupled		Yoke Mounted		Ends
	A	B	A1	B1	
2 1/2	16.52	11.06	30.14	24.68	Screwed
	16.33	10.87	29.95	24.49	Flanged
3	17.41	11.95	31.03	25.57	Screwed
	17.23	11.77	30.85	25.39	Flanged
4	18.58	13.12	32.20	26.74	Flanged
6	21.26	15.80	34.88	29.42	Flanged
8	25.13	19.67	38.75	33.29	Flanged

Straightway Valves					
Valve Size	Close Coupled		Yoke Mounted		Ends
	A	B	A1	B1	
2 1/2	17.78	12.32	31.40	25.94	Flanged
3	17.75	12.29	31.37	25.91	Flanged
4	18.78	13.32	32.40	26.94	Flanged
6	22.06	16.60	35.68	30.22	Flanged

Dualrange Valves					
Valve Size	Close Coupled		Yoke Mounted		Ends
	A	B	A1	B1	
2 1/2	19.08	13.62	32.70	27.24	Screwed
	18.89	13.43	32.51	27.05	Flanged
3	20.26	14.80	33.88	28.42	Screwed
	20.08	14.62	33.70	28.24	Flanged
4	21.62	16.16	35.24	29.78	Flanged
6	25.35	19.89	38.97	33.51	Flanged

Bill of Materials

Series 31130 Direct Acting

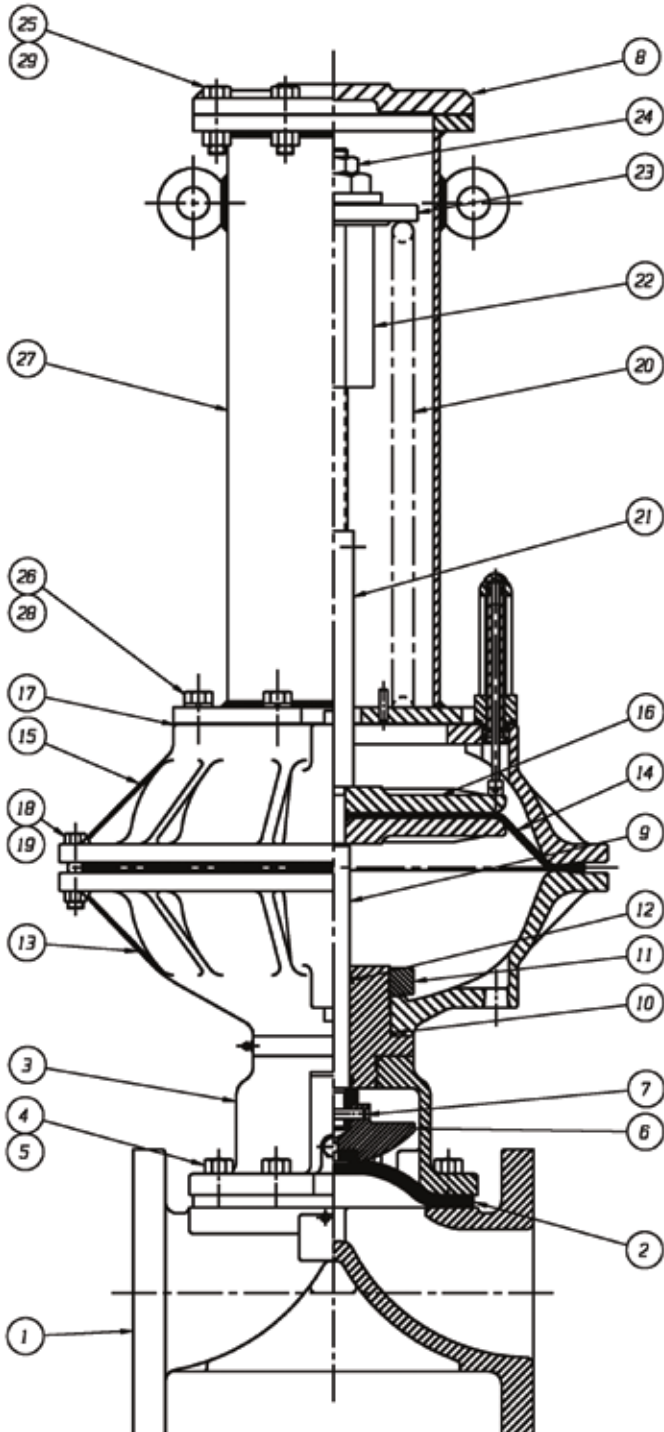

LIST OF PARTS			
ITEM	DESCRIPTION	MATERIAL	QTY.
1	BODY, FLANGED	-	1
2	DIAPHRAGM, ELASTOMER	-	1
3	BONNET, ADAPTER	-	1
4	HEX, CAP SCREWS OR STUDS	-	SEE CHARTS
5	NUTS	-	SEE CHARTS
6	COMPRESSOR, F/ ELASTOMER DIAPHRAGM	CI	1
7	PIN, SPIROL	STN.STL.	1
8	CAP	DI	1
9	SPINDLE, VALVE	STN STL	1
10	O-RING #238	BUNA-N	1
11	NUT, ADAPTER BUSHING	DI	1
12	O-RING #214	BUNA-N	1
13	COVER, LOWER	ALUMINUM	1
14	DIAPHRAGM, AIR MOTOR	BUNA-N	1
15	COVER, UPPER	ALUMINUM	1
16	PLATE, ACTUATOR	DI	2
17	GASKET	SILICONE	1
18	SCREW, HEX HD. CAP	C.STL	24
19	NUT, HEX	C.STL	24
20	SPRING	C.STL	1
21	SPINDLE EXTENSION ASSEMBLY	-	1
22	BUSHING, ADJUSTING	DI	1
23	PLATE, SPRING	C.STL	1
24	NUT, HEX JAM	C.STL	1
25	SCREW, HEX HD CAP	C.STL	8
26	WASHER, SPRINGLOCK	C.STL	8
27	ASSEMBLY SPRING CASING	C.STL	1
28	SCREW, HEX HD CAP	C.STL	8
29	NUT, HEX	C.STL	8

Dimensional Data

Series 31130 Direct Acting

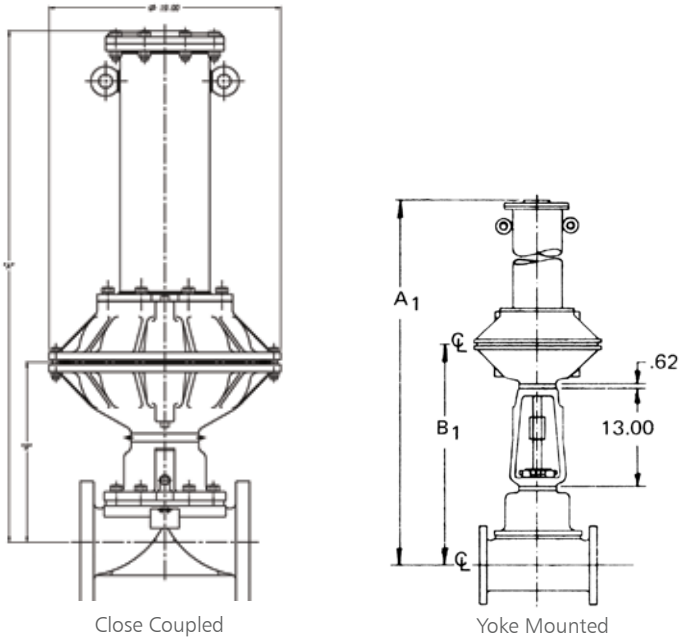

LIMIT SWITCHES	G&K	H&J
BZE6-2RN or DTE6-2RN	9.50	8.44
BAF1-2RN-RH or DTF2-2RN-RH	9.81	9.00
EX-Q or EXD-Q	10.50	10.19

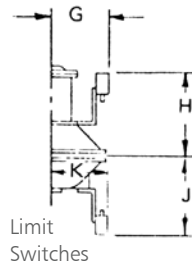

Limit Switches

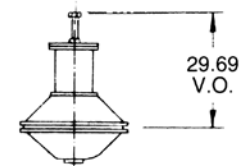

Adjustable Opening Stop

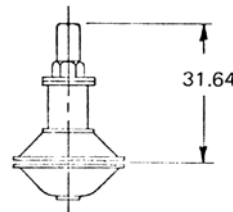

Adjustable Travel Stops

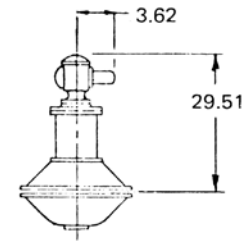

Positioner (Moore & Conoflow)

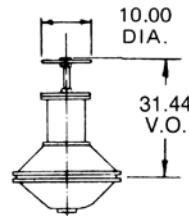

Handwheel Closing

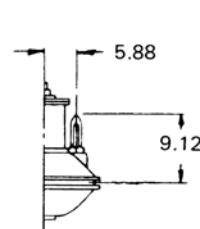

Position Indicator

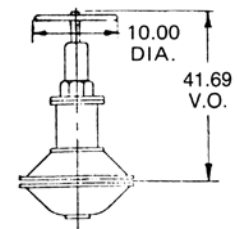

Adjustable Travel and Adjustable Opening Stop with Handwheel

Weir Valves

Valve Size	Close Coupled		Yoke Mounted		Ends
	A	B	A1	B1	
2 1/2	35.14	11.06	48.76	24.68	Screwed
	34.95	10.87	48.57	24.49	Flanged
3	36.03	11.95	49.65	25.57	Screwed
	35.85	11.77	49.47	25.39	Flanged
4	37.20	13.12	50.82	26.74	Flanged
6	39.88	15.80	53.50	29.42	Flanged
8	43.75	19.67	57.37	33.29	Flanged

Straightway Valves

Valve Size	Close Coupled		Yoke Mounted		Ends
	A	B	A1	B1	
2 1/2	36.40	12.32	50.02	25.94	Flanged
3	36.37	12.29	49.99	25.91	Flanged
4	37.40	13.32	51.02	26.94	Flanged
6	40.68	16.60	54.30	30.22	Flanged

Dualrange Valves

Valve Size	Close Coupled		Yoke Mounted		Ends
	A	B	A1	B1	
2 1/2	37.70	13.62	51.32	27.24	Screwed
	37.51	13.43	51.13	27.05	Flanged
3	38.88	14.80	52.50	28.42	Screwed
	38.70	14.62	52.32	28.24	Flanged
4	40.24	16.16	53.86	29.78	Flanged
6	43.97	19.89	57.59	33.51	Flanged

Bill of Materials

Series 32131-137 Reverse Acting

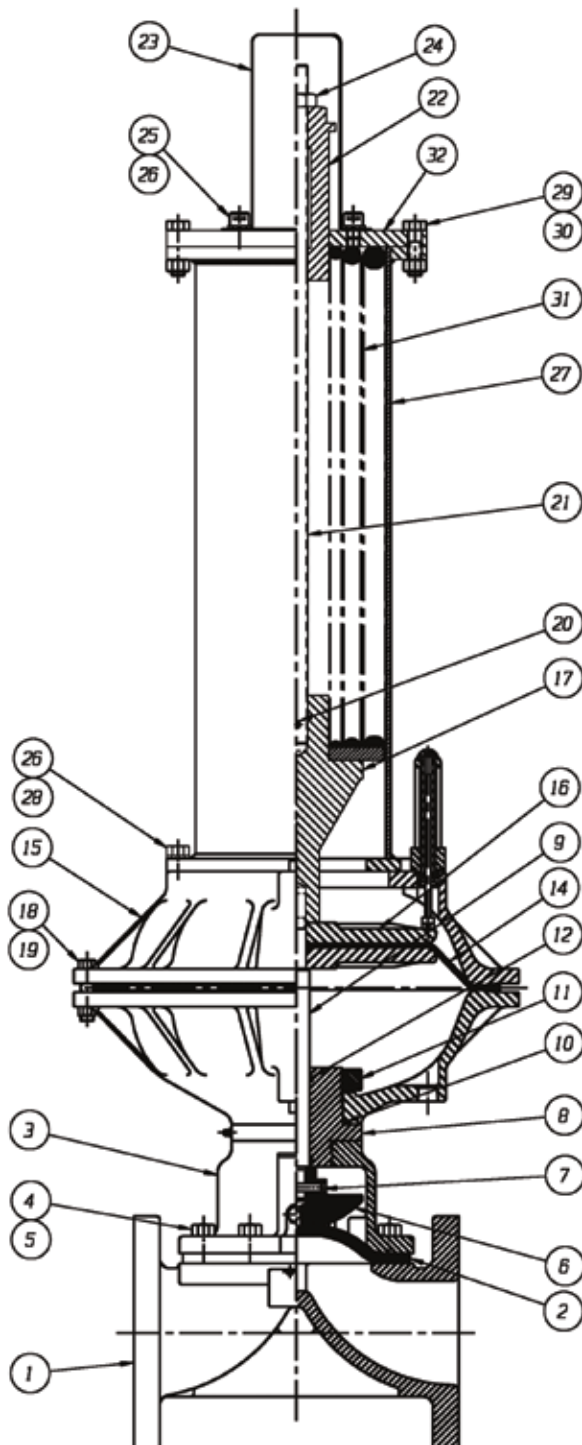

LIST OF PARTS			
ITEM	DESCRIPTION	MATERIAL	QTY.
1	BODY, FLANGED	-	1
2	DIAPHRAGM	-	1
3	BONNET, ADAPTER	-	1
4	HEX, CAP SCREWS OR STUDS	-	AR
5	NUTS	-	AR
6	COMPRESSOR, F/ ELASTOMER DIAPHRAGM	CI	1
7	PIN, SPIROL	STN STL	1
8	BUSHING, ADAPTER	OI	1
9	SPINDLE, VALVE	STN STL	1
10	D-RING #238	BLMA-N	1
11	NUT, ADAPTER BUSHING	OI	1
12	D-RING	BLMA-N	1
13	COVER, LOWER	ALUMINUM	1
14	DIAPHRAGM, AIR MOTOR	BLMA-N	1
15	COVER, UPPER	ALUMINUM	1
16	PLATE, ACTUATOR	OI	2
17	CONNECTOR, SPINDLE	OI	1
18	SCREW, HEX HD. CAP	C STL	24
19	NUT, HEX	C STL	24
20	PIN, SPIROL	STN STL	1
21	EXTENSION, SPINDLE	C STL	1
22	BUSHING, ADJUSTING	OI	1
23	SHIELD, TRAVEL STOP	C STL	1
24	NUT, HEX JAM	C STL	1
25	SCREW, HEX SDC HD CAP	C STL	2
26	WASHER, SPRINGLOCK	C STL	10
27	ASSEMBLY, SPRING CASING	C STL	1
28	SCREW, HEX HD CAP	C STL	8
29	SCREW, HEX HD CAP	C STL	8
30	NUT, HEX	C STL	8
31	SPRING	C STL	AR
32	COVER, SPRING CASE	C STL	1

Dimensional Data

Series 32131-137 Reverse Acting

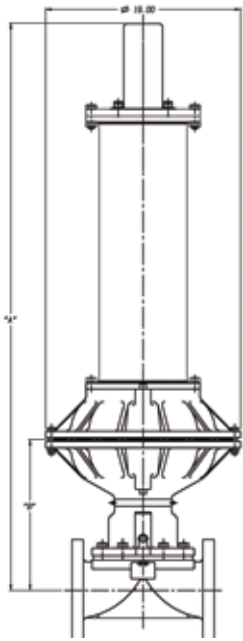

Close Coupled

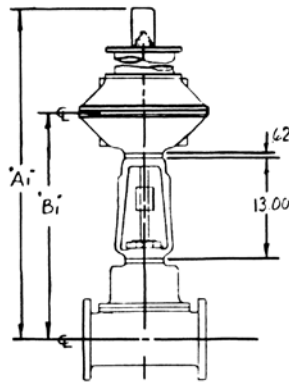

Yoke Mounted

LIMIT SWITCHES	G&K	H&J
BZE6-2RN or DTE6-2RN	9.50	8.44
BAF1-2RN-RH or DTF2-2RN-RH	9.81	9.00
EX-Q or EXD-Q	10.50	10.19

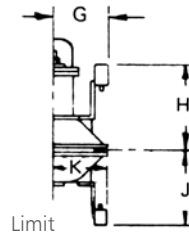

Limit Switches

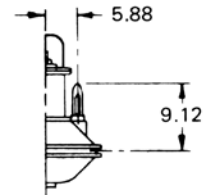

Position Indicator

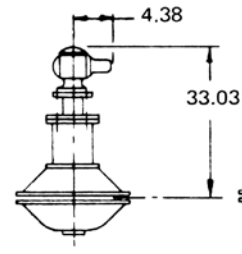

Positioner
(Moore & Conoflow)

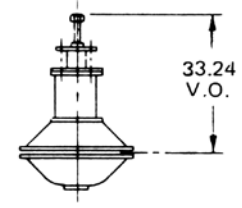

Adjustable
Opening Stop

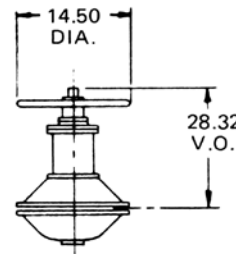

Handwheel
Opening Device

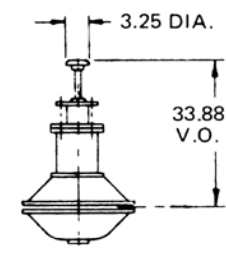

Adjustable Opening Stop
with Handwheel

Weir Valves

Valve Size	Close Coupled		Yoke Mounted		Ends
	A	B	A1	B1	
2 1/2	38.18	11.87	51.80	24.68	Screwed
	37.99	10.87	51.61	24.49	Flanged
3	39.07	11.95	52.69	25.57	Screwed
	38.89	11.77	52.51	25.39	Flanged
4	40.24	13.12	53.86	26.74	Flanged
6	42.92	15.80	56.54	29.42	Flanged
8	46.79	19.67	60.41	33.29	Flanged

Straightway Valves

Valve Size	Close Coupled		Yoke Mounted		Ends
	A	B	A1	B1	
2 1/2	39.44	12.32	53.06	25.94	Flanged
3	39.41	12.29	53.03	25.91	Flanged
4	40.44	13.32	54.06	26.94	Flanged

Dualrange Valves

Valve Size	Close Coupled		Yoke Mounted		Ends
	A	B	A1	B1	
2 1/2	40.74	13.62	54.36	27.24	Screwed
	40.55	13.43	54.17	27.05	Flanged
3	41.92	14.80	55.54	28.42	Screwed
	41.74	14.62	55.36	28.42	Flanged
4	43.28	16.16	56.90	29.78	Flanged

Bill of Materials

Series 32138 Reverse Acting

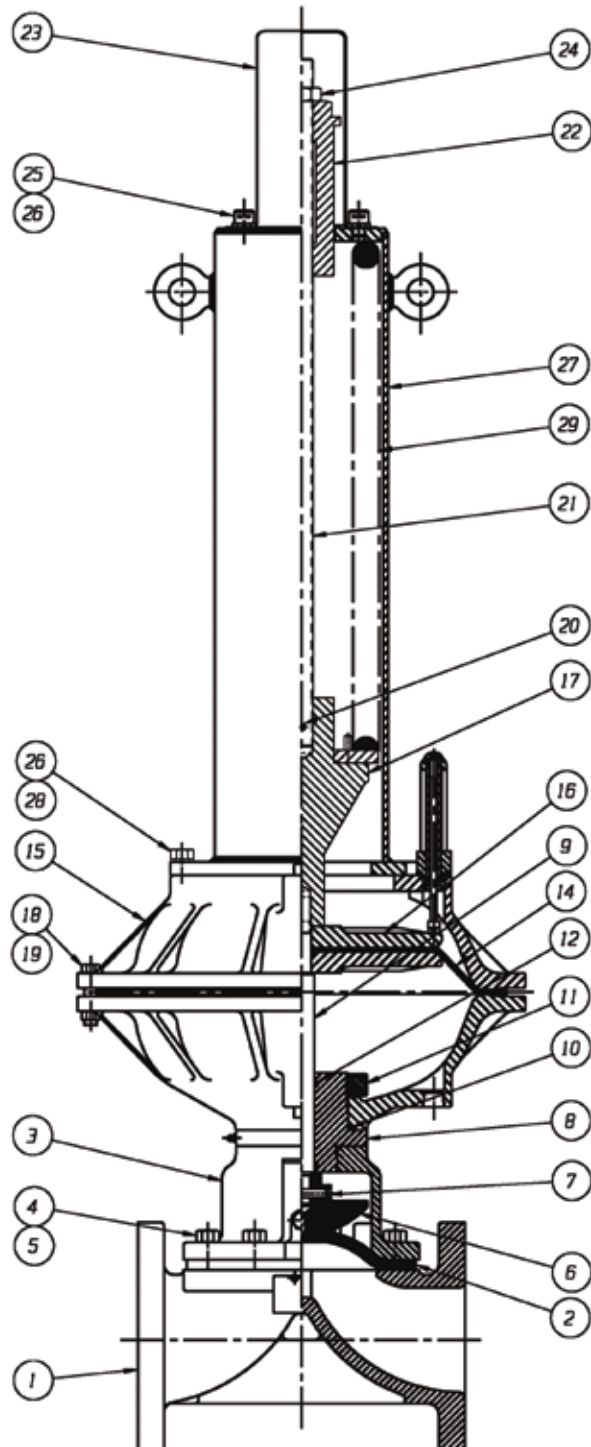

LIST OF PARTS			
ITEM	DESCRIPTION	MATERIAL	QTY.
1	BODY, FLANGED	-	1
2	DIAPHRAGM	-	1
3	BONNET, ADAPTER	-	1
4	HEX, CAP SCREWS OR STUDS	-	AR
5	NUTS	-	AR
6	COMPRESSOR, F/ ELASTOMER DIAPHRAGM	CI	1
7	PIN, SPIRAL	STN STL	1
8	BUSHING, ADAPTER	DI	1
9	SPINDLE, VALVE	STN STL	1
10	O-RING #238	BUNA-N	1
11	NUT, ADAPTER BUSHING	DI	1
12	O-RING	BUNA-N	1
13	COVER, LOWER	ALUMINUM	1
14	DIAPHRAGM, AIR MOTOR	BUNA-N	1
15	COVER, UPPER	ALUMINUM	1
16	PLATE, ACTUATOR	DI	2
17	CONNECTOR, SPINDLE	DI	1
18	SCREW, HEX HD. CAP	C STL	24
19	NUT, HEX	C STL	24
20	PIN, SPIRAL	STN STL	1
21	EXTENSION, SPINDLE	C STL	1
22	BUSHING, ADJUSTING	DI	1
23	SHIELD, TRAVEL STOP	C STL	1
24	NUT, HEX JAM	C STL	1
25	SCREW, HEX SD. HD CAP	C STL	2
26	WASHER, SPRINGLOCK	C STL	10
27	ASSEMBLY, SPRING CASING	C STL	1
28	SCREW, HEX HD CAP	C STL	8
29	SPRING, #130	C STL	AR

Dimensional Data

Series 32138 Reverse Acting

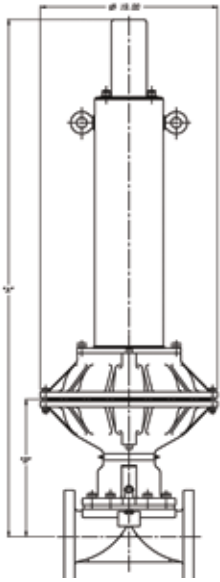

Close Coupled

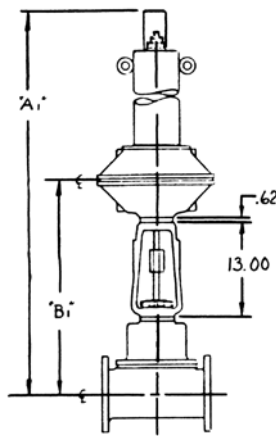

Yoke Mounted

LIMIT SWITCHES	G&K	H&J
BZE6-2RN or DTE6-2RN	9.50	8.44
BAF1-2RN-RH or DTF2-2RN-RH	9.81	9.00
EX-Q or EXD-Q	10.50	10.19

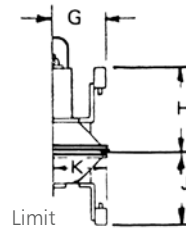

Limit Switches

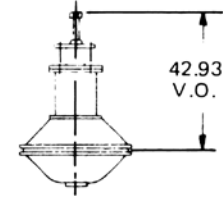

Adjustable Opening Stop

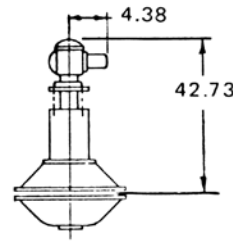

Positioner
(Moore & Conoflow)

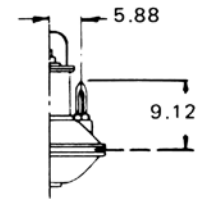

Position Indicator

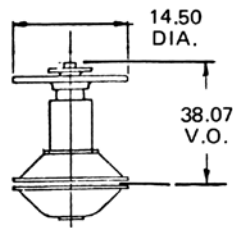

Handwheel
Opening Device

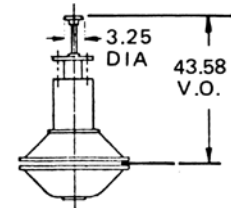

Adjustable Opening Stop
with Handwheel

Weir Valves

Valve Size	Close Coupled		Yoke Mounted		Ends
	A	B	A1	B1	
2 1/2	47.87	11.06	61.49	24.68	Screwed
	47.68	10.87	61.30	24.49	Flanged
3	48.76	11.95	62.38	25.57	Screwed
	48.58	11.77	62.20	25.39	Flanged
4	49.93	13.12	63.55	26.74	Flanged
6	52.61	15.80	66.23	29.42	Flanged
8	56.48	19.67	70.10	33.29	Flanged

Straightway Valves

Valve Size	Close Coupled		Yoke Mounted		Ends
	A	B	A1	B1	
2 1/2	49.13	12.32	62.75	25.94	Flanged
3	49.10	12.29	62.72	25.91	Flanged
4	50.13	13.32	63.75	26.94	Flanged
6	53.41	16.60	67.03	30.22	Flanged

Dualrange Valves

Valve Size	Close Coupled		Yoke Mounted		Ends
	A	B	A1	B1	
2 1/2	50.43	13.62	64.05	27.24	Screwed
	50.24	13.43	63.86	27.05	Flanged
3	51.61	14.80	65.23	28.42	Screwed
	51.43	14.62	65.05	28.42	Flanged
4	52.97	16.16	66.56	29.78	Flanged
6	56.70	19.89	70.32	33.51	Flanged

Bill of Materials

Series 33250 Double Acting

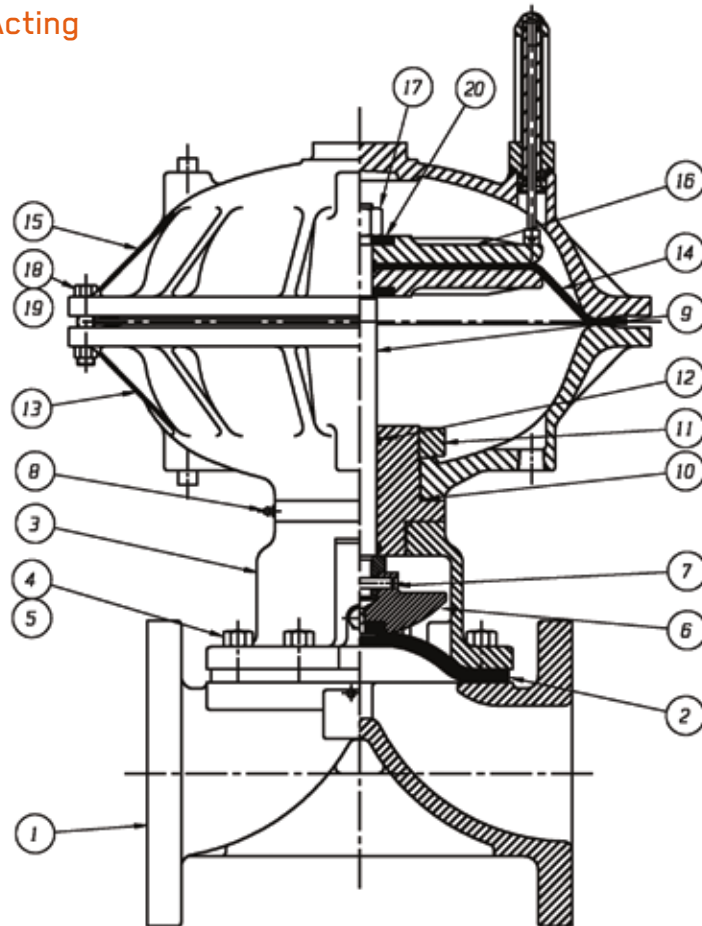

LIST OF PARTS			
ITEM	DESCRIPTION	MATERIAL	QTY.
1	BODY, FLANGED	-	1
2	DIAPHRAGM, ELASTOMER	-	1
3	BONNET, ADAPTER	-	1
4	HEX, CAP SCREWS OR STUDS	-	AR
5	NUTS	-	AR
6	COMPRESSOR, F/ ELASTOMER DIAPHRAGM	CI	1
7	PIN, SPIROL	STN STL	1
8	FITTING, LUBE	-	1
9	SPINDLE, VALVE	STN STL	1
10	O-RING	BUNA-N	1
11	NUT, ADAPTER BUSHING	DI	1
12	O-RING	BUNA-N	1
13	COVER, LOWER	ALUMINUM	1
14	DIAPHRAGM, AIR MOTOR	BUNA-N	1
15	COVER, UPPER	ALUMINUM	1
16	PLATE, ACTUATOR	DI	2
17	NUT, HEAVY HEX.	C.STL	1
18	SCREW, HEX HD. CAP	C.STL	24
19	NUT, HEX	C.STL	24
20	WASHER, IMPACT	STEEL	2

Dimensional Data

Series 33250 Double Acting

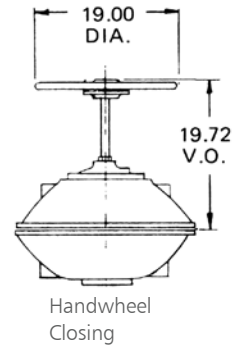
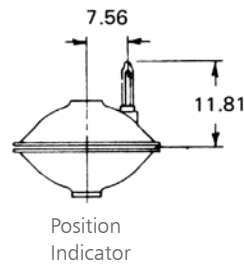
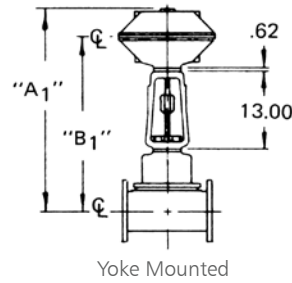
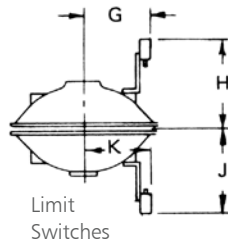
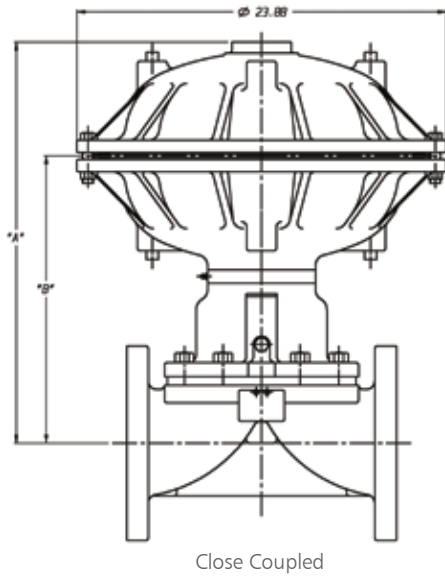

LIMIT SWITCHES	G	H	J	K
BZE6-2RN or DTE6-2RN	11.19	9.94	9.94	11.19
BAF1-2RN-RH or DTF2-2RN-RH	11.50	10.50	10.50	11.50
EX-Q or EXD-Q	12.19	11.62	11.62	12.19

Weir Valves					
Valve Size	Close Coupled		Yoke Mounted		Ends
	A	B	A1	B1	
4	22.70	15.12	36.32	28.74	Flanged
6	25.38	17.80	39.00	31.42	Flanged
8	29.25	21.67	42.87	35.29	Flanged
10	31.89	24.31	45.51	37.93	Flanged

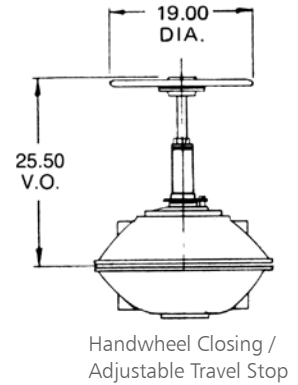
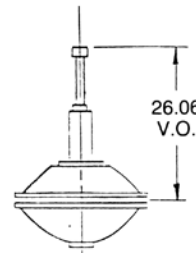

Straightway Valves					
Valve Size	Close Coupled		Yoke Mounted		Ends
	A	B	A1	B1	
2 1/2	21.90	14.32	35.52	27.94	Flanged
3	21.87	14.29	35.49	27.91	Flanged
4	22.90	15.32	36.52	28.94	Flanged
6	26.18	18.60	39.80	32.22	Flanged
8	30.94	23.36	44.56	36.98	Flanged
10	34.44	26.86	48.06	40.48	Flanged
12	34.44	26.86	48.06	40.48	Flanged

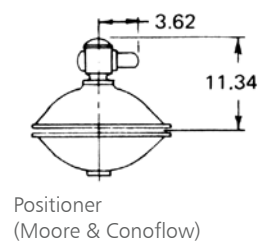
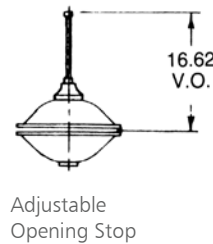

Dualrange Valves					
Valve Size	Close Coupled		Yoke Mounted		Ends
	A	B	A1	B1	
6	29.47	21.89	43.09	35.51	Flanged

Bill of Materials

Series 31250 Direct Acting

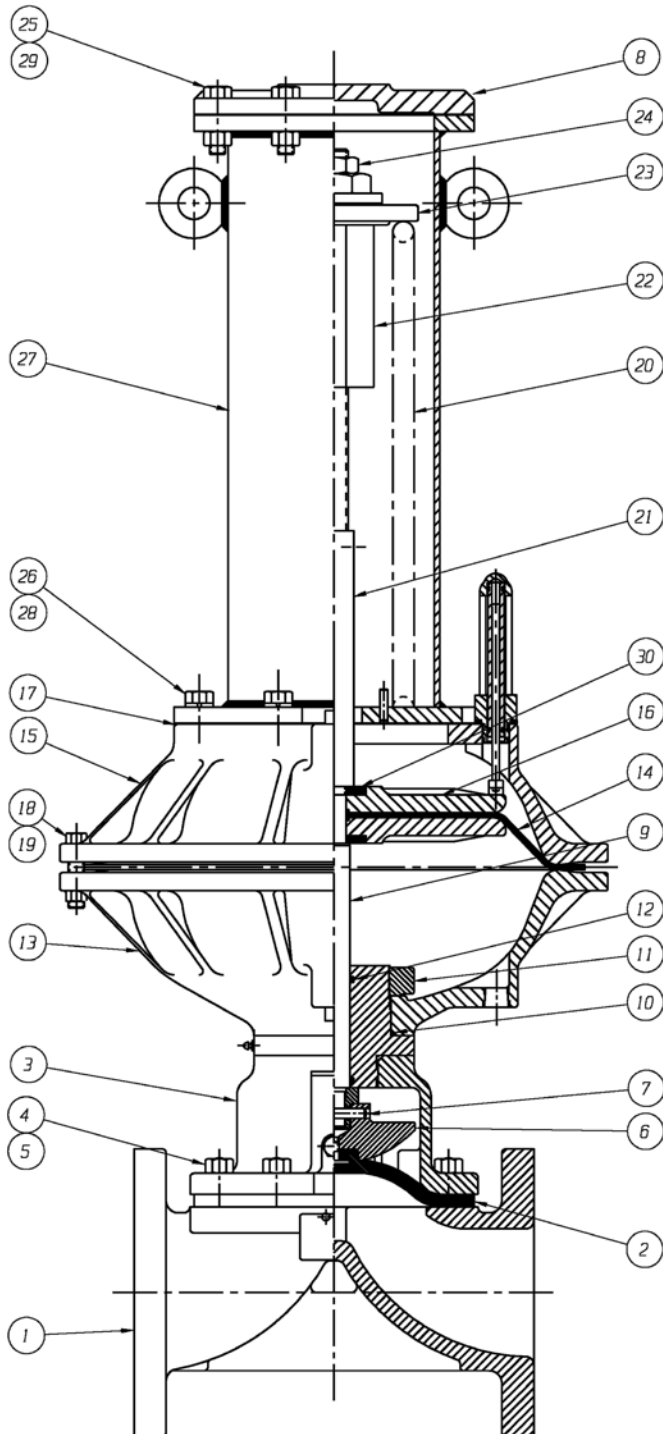

LIST OF PARTS			
ITEM	DESCRIPTION	MATERIAL	QTY.
1	BODY, FLANGED	-	1
2	DIAPHRAGM, ELASTOMER	-	1
3	BONNET, ADAPTER	-	1
4	HEX, CAP SCREWS OR STUDS	-	SEE CHARTS
5	NUTS	-	SEE CHARTS
6	COMPRESSOR, F/ ELASTOMER DIAPHRAGM	CI	1
7	PIN, SPIRDL	STN.STL.	1
8	CAP	DI	1
9	SPINDLE, VALVE	STN STL	1
10	O-RING #23B	BUNA-N	1
11	NUT, ADAPTER BUSHING	DI	1
12	O-RING #214	BUNA-N	1
13	COVER, LOWER	ALUMINUM	1
14	DIAPHRAGM, AIR MOTOR	BUNA-N	1
15	COVER, UPPER	ALUMINUM	1
16	PLATE, ACTUATOR	DI	2
17	GASKET	SILICONE	1
18	SCREW, HEX HD. CAP	C.STL	24
19	NUT, HEX	C.STL	24
20	SPRING	C.STL	1
21	SPINDLE EXTENSION ASSEMBLY	-	1
22	BUSHING, ADJUSTING	DI	1
23	PLATE, SPRING	C.STL	1
24	NUT, HEX JAM	C.STL	1
25	SCREW, HEX HD CAP	C.STL	8
26	WASHER, SPRINGLOCK	C.STL	8
27	ASSEMBLY SPRING CASING	C.STL	1
28	SCREW, HEX HD CAP	C.STL	8
29	NUT, HEX	C.STL	8
30	WASHER, IMPACT	STEEL	1

Dimensional Data

Series 31250 Direct Acting

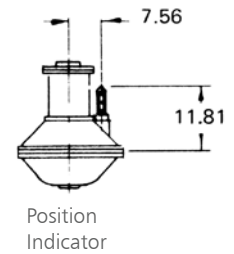
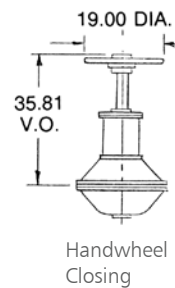
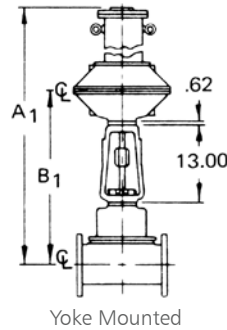
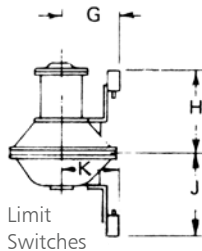
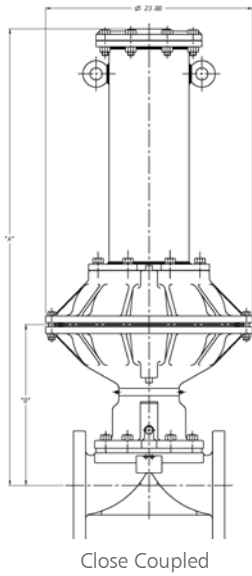

LIMIT SWITCHES	G	H	J	K
BZE6-2RN or DTE6-2RN	11.19	9.94	9.94	11.19
BAF1-2RN-RH or DTF2-2RN-RH	11.50	10.50	10.50	11.50
EX-Q or EXD-Q	12.19	11.62	11.62	12.19

Weir Valves					
Valve Size	Close Coupled		Yoke Mounted		Ends
	A	B	A1	B1	
4	41.20	15.12	54.82	28.74	Flanged
6	43.88	17.80	57.50	31.42	Flanged
8	47.75	21.67	61.37	35.29	Flanged
10	50.39	24.31	64.01	37.93	Flanged

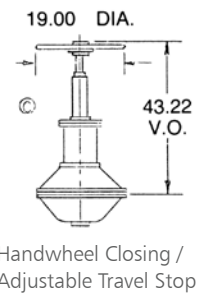
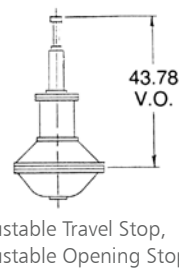

Straightway Valves					
Valve Size	Close Coupled		Yoke Mounted		Ends
	A	B	A1	B1	
2 1/2	40.40	14.32	54.02	27.94	Flanged
3	40.37	14.29	53.99	27.91	Flanged
4	41.40	15.32	55.02	28.94	Flanged
6	44.68	18.60	58.30	32.22	Flanged
8	49.44	23.36	63.06	36.98	Flanged
10	52.94	26.86	66.56	40.48	Flanged
12	52.94	26.86	66.56	40.48	Flanged

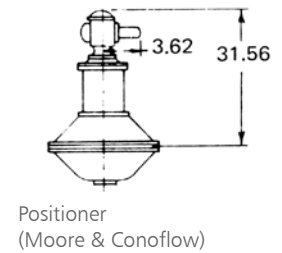
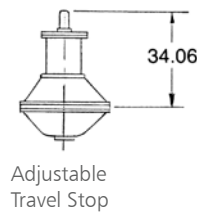

Dualrange Valves					
Valve Size	Close Coupled		Yoke Mounted		Ends
	A	B	A1	B1	
6	47.97	21.89	61.59	35.51	Flanged

Bill of Materials

Series 32253 Reverse Acting

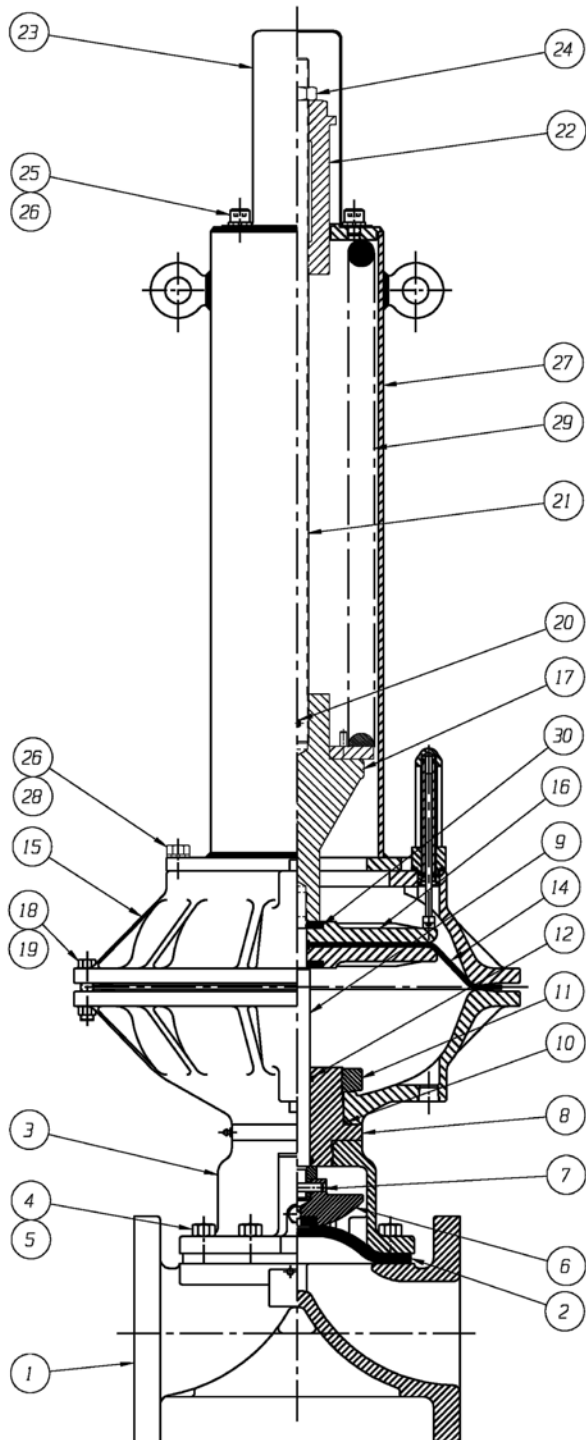

LIST OF PARTS			
ITEM	DESCRIPTION	MATERIAL	QTY.
1	BODY, FLANGED	-	1
2	DIAPHRAGM	-	1
3	BONNET, ADAPTER	-	1
4	HEX, CAP SCREWS OR STUDS	-	AR
5	NUTS	-	AR
6	COMPRESSOR, F/ ELASTOMER DIAPHRAGM	CI	1
7	PIN, SPIROL	STN STL	1
8	BUSHING, ADAPTER	DI	1
9	SPINDLE, VALVE	STN STL	1
10	O-RING #238	BLUNA-N	1
11	NUT, ADAPTER BUSHING	DI	1
12	O-RING	BLUNA-N	1
13	COVER, LOWER	ALUMINUM	1
14	DIAPHRAGM, AIR MOTOR	BLUNA-N	1
15	COVER, UPPER	ALUMINUM	1
16	PLATE, ACTUATOR	DI	2
17	CONNECTOR, SPINDLE	DI	1
18	SCREW, HEX HD. CAP	C STL	24
19	NUT, HEX	C STL	24
20	PIN, SPIROL	STN STL	1
21	EXTENSION, SPINDLE	C STL	1
22	BUSHING, ADJUSTING	DI	1
23	SHEILD, TRAVEL STOP	C STL	1
24	NUT, HEX JAM	C STL	1
25	SCREW, HEX SOC HD CAP	C STL	2
26	WASHER, SPRINGLOCK	C STL	10
27	ASSEMBLY, SPRING CASING	C STL	1
28	SCREW, HEX HD CAP	C STL	8
29	SPRING, #130	C STL	AR
30	WASHER, IMPACT	STEEL	2

Dimensional Data

Series 32253 Reverse Acting

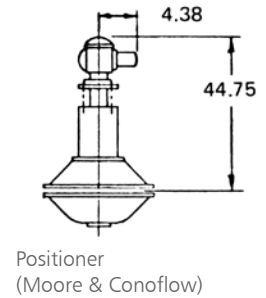
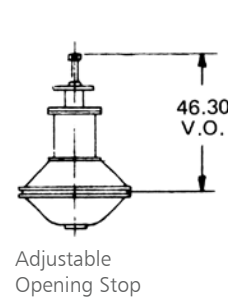
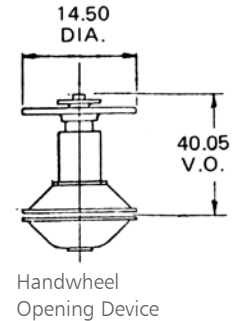
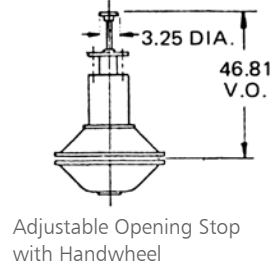
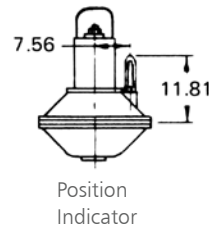
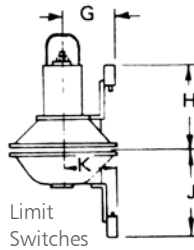
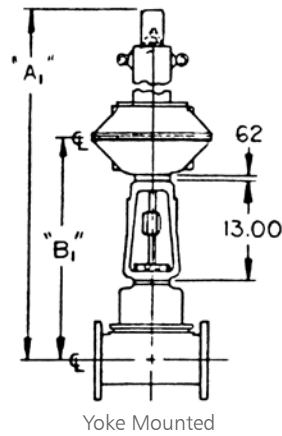
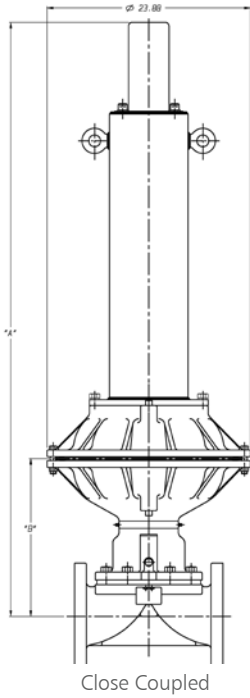

LIMIT SWITCHES	G	H	J	K
BZE6-2RN or DTE6-2RN	11.19	9.94	9.94	11.19
BAF1-2RN-RH or DTF2-2RN-RH	11.50	10.50	10.50	11.50
EX-Q or EXD-Q	12.19	11.62	11.62	12.19

Weir Valves					
Valve Size	Close Coupled		Yoke Mounted		Ends
	A	B	A1	B1	
4	53.93	15.12	67.55	28.74	Flanged
6	56.61	17.80	70.23	31.42	Flanged
8	60.48	21.67	74.09	35.29	Flanged

Straightway Valves					
Valve Size	Close Coupled		Yoke Mounted		Ends
	A	B	A1	B1	
2 1/2	53.13	14.32	66.75	27.94	Flanged
3	53.10	14.29	66.72	27.91	Flanged
4	54.13	15.32	67.75	28.94	Flanged
6	57.41	18.60	71.03	32.22	Flanged

Dualrange Valves					
Valve Size	Close Coupled		Yoke Mounted		Ends
	A	B	A1	B1	
6	60.70	21.89	74.32	35.51	Flanged

Bill of Materials

Series 32251-252 Reverse Acting

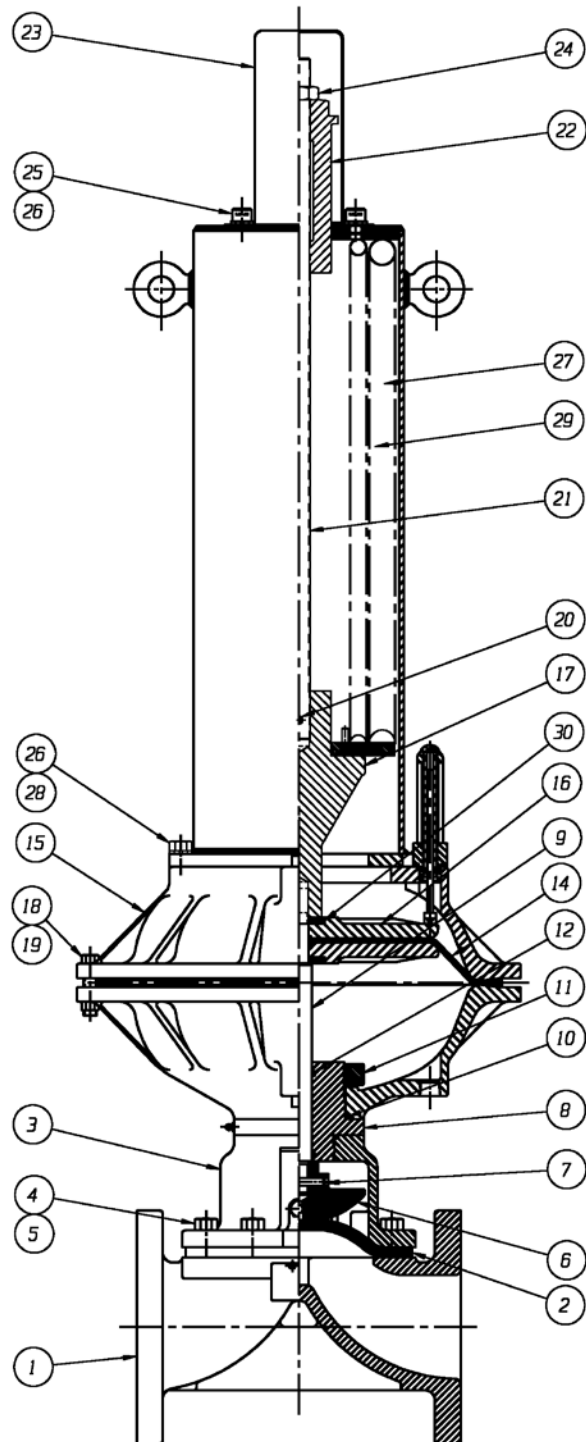

LIST OF PARTS			
ITEM	DESCRIPTION	MATERIAL	QTY.
1	BODY, FLANGED	-	1
2	DIAPHRAGM	-	1
3	BONNET, ADAPTER	-	1
4	HEX, CAP SCREWS OR STUDS	-	AR
5	NUTS	-	AR
6	COMPRESSOR, F/ ELASTOMER DIAPHRAGM	CI	1
7	PIN, SPIROL	STN STL	1
8	BUSHING, ADAPTER	DI	1
9	SPINDLE, VALVE	STN STL	1
10	O-RING #23B	BUINA-N	1
11	NUT, ADAPTER BUSHING	DI	1
12	O-RING	BUINA-N	1
13	COVER, LOWER	ALUMINUM	1
14	DIAPHRAGM, AIR MOTOR	BUINA-N	1
15	COVER, UPPER	ALUMINUM	1
16	PLATE, ACTUATOR	DI	2
17	CONNECTOR, SPINDLE	DI	1
18	SCREW, HEX HD. CAP	C STL	24
19	NUT, HEX	C STL	24
20	PIN, SPIROL	STN STL	1
21	EXTENSION, SPINDLE	C STL	1
22	BUSHING, ADJUSTING	DI	1
23	SHEILD, TRAVEL STOP	C STL	1
24	NUT, HEX JAM	C STL	1
25	SCREW, HEX SOC HD CAP	C STL	2
26	WASHER, SPRINGLOCK	C STL	10
27	ASSEMBLY, SPRING CASING	C STL	1
28	SCREW, HEX HD CAP	C STL	8
29	SPRING, #130	C STL	AR
30	WASHER, IMPACT	STEEL	2

Dimensional Data

Series 32251-252 Reverse Acting

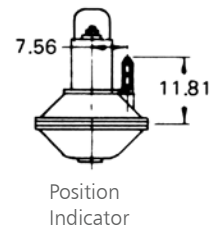
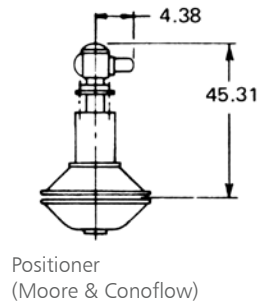
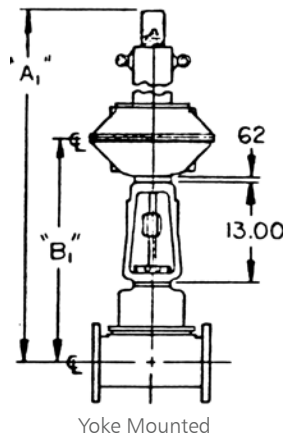
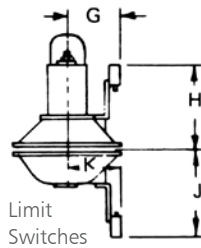
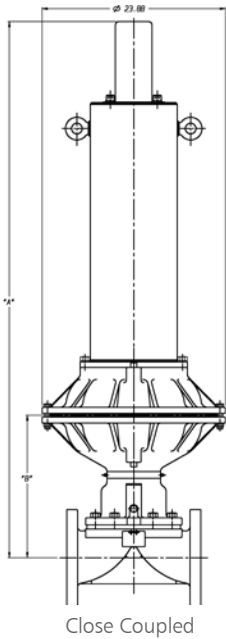

LIMIT SWITCHES				
	G	H	J	K
BZE6-2RN or DTE6-2RN	11.19	9.94	9.94	11.19
BAF1-2RN-RH or DTF2-2RN-RH	11.50	10.50	10.50	11.50
EX-Q or EXD-Q	12.19	11.62	11.62	12.19

Weir Valves					
Valve Size	Close Coupled		Yoke Mounted		Ends
	A	B	A1	B1	
4	54.49	15.12	68.11	28.74	Flanged
6	57.17	17.80	70.79	31.42	Flanged
8	61.04	21.67	74.66	35.29	Flanged
10	63.68	24.31	77.30	37.93	Flanged

Straightway Valves					
Valve Size	Close Coupled		Yoke Mounted		Ends
	A	B	A1	B1	
2 1/2	53.69	14.32	67.31	27.94	Flanged
3	53.66	14.29	67.28	27.91	Flanged
4	54.69	15.32	68.31	28.94	Flanged
6	57.97	18.60	71.59	32.22	Flanged
8	62.73	23.36	76.35	36.98	Flanged

Dualrange Valves					
Valve Size	Close Coupled		Yoke Mounted		Ends
	A	B	A1	B1	
6	61.26	21.89	74.88	35.51	Flanged

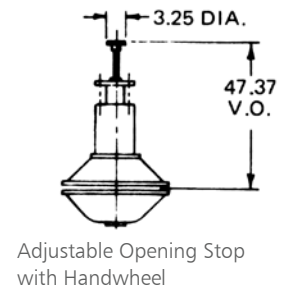
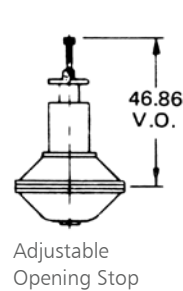

Bill of Materials for Advantage[®] Actuators

Series 05-Series 16 Actuators

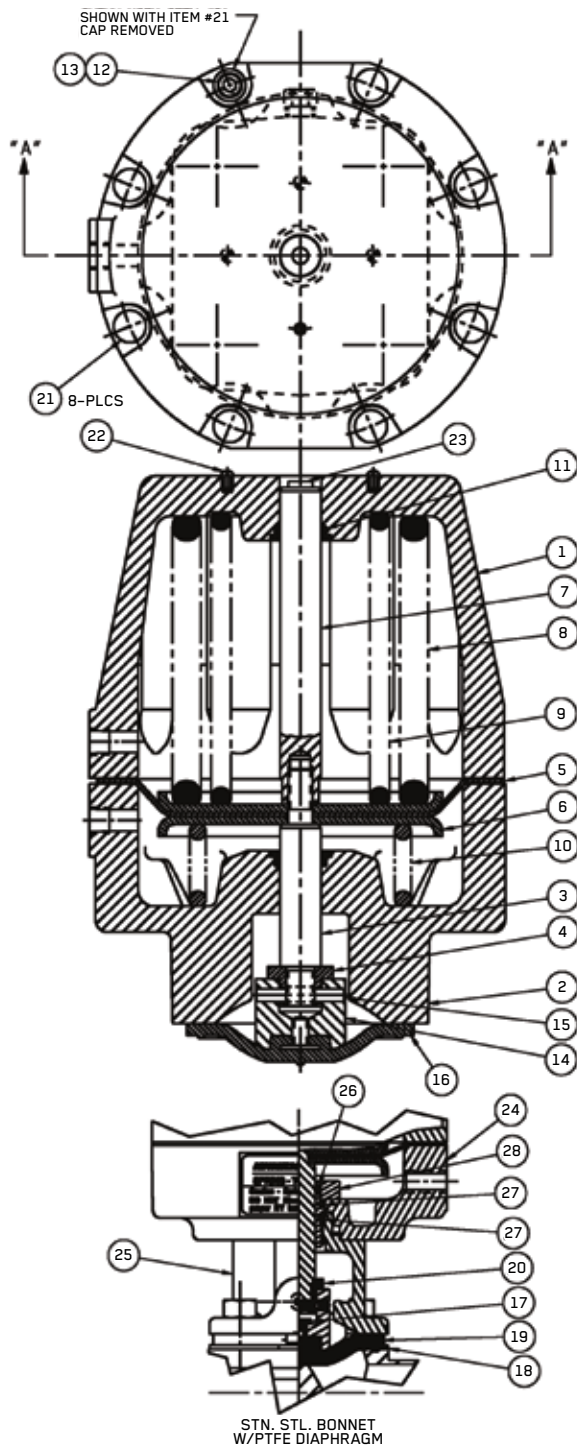

LIST OF PARTS			
ITEM	DESCRIPTION	MATERIAL	QTY.
1	COVER-UPPER ACTUATOR	PES	1
2	COVER-LOWER ACTUATOR	PES	1
3	SPINDLE-VALVE	STN, STL,	1
4	COLLAR-STOP	STN, STL,	1
5	DIAPHRAGM-ACTUATOR	BUNA-N	1
6	PLATE-ACTUATOR	STN, STL,	2
7	SPINDLE-INDICATING	STN, STL,	1
8	SPRING-OUTER REVERSE ACTING ONLY	CHROME SILICON	1
9	SPRING-INNER REVERSE ACTING ONLY	CHROME SILICON	1
10	SPRING DIRECT ACTING ONLY	CHROME SILICON	1
11	O-RING DASH #114	VITON	2
12	SCREW-HEX SOC HD CAP	STN, STL,	8
13	WASHER	STN, STL,	8
14	COMPRESSOR F/ ELASTOMER DIAPHRAGM	-	1
15	PIN-SPIROL	STN, STL,	1
16	DIAPHRAGM-ELASTOMER	-	1
17	NUT-TUBE	BRASS	1
18	DIAPHRAGM-PTFE	PTFE	1
19	CUSHION-BACKING	EPDM	1
20	COMPRESSOR F/ PTFE DIAPHRAGM	-	1
21	CAP	NEOPRENE	8
22	SCREW-RD HD	STN, STL,	4
23	PLUG	PLASTIC	1
24	COVER-LOWER LOW PROFILE	PES	1
25	BONNET LOW-PROFILE	STN, STL,	1
26	O-RING	FKM	1
27	O-RING	FKM	2
28	BUSHING	BRONZE	1

Bill of Materials for Advantage[®] Actuators

Series 33 Actuators

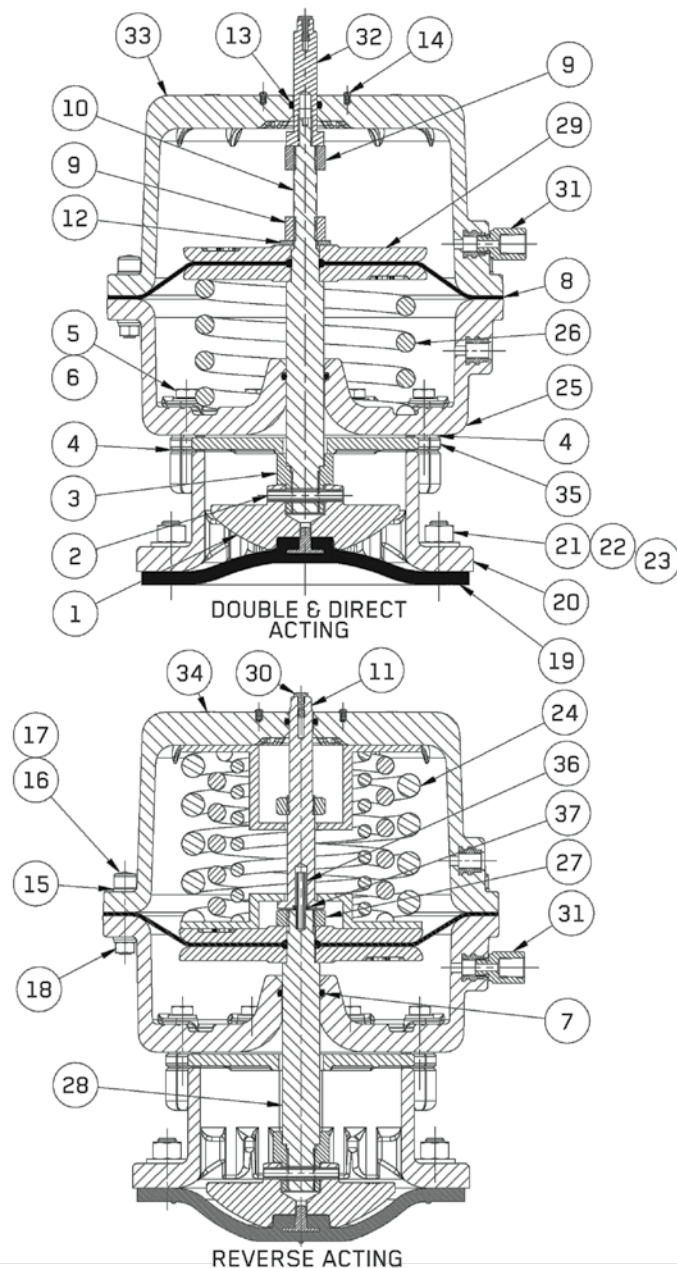

LIST OF PARTS			
ITEM	DESCRIPTION	MATERIAL	QTY.
1	COMPRESSOR	BRZ. OR CI.	1
2	PIN-SPIROL	STN.STL.	1
3	COLLAR-STOP	STN.STL.	1
4	GASKET	EPDM	2
5	WASHER-PLAIN	STN.STL.	8
6	SCREW-HEX HD CAP	CS.	8
7	O-RING	BUNA-N	1
8	DIAPHRAGM-ACTUATOR	BUNA-N	1
9	NUT-HEX	CS.	2
10	SPINDLE (DIRECT-DOUBLE)	STN.STL.	1
11	BUSHING-ADJUSTING	STN.STL.	1
12	WASHER-PLAIN	CS	1
13	O-RING	BUNA-N	1
14	SCREW-MACH	STN.STL.	4
15	WASHER-PLAIN	STN.STL.	24
16	CAP	VINYL	12
17	SCREW-HEX SOC	STN.STL.	12
18	NUT-HEX	STN.STL.	12
19	DIAPHRAGM-ELASTOMER	-	1
20	BONNET	DI. NYLON COATED	1
21	WASHER-PLAIN	STN.STL.	AR
22	NUT-HEX	STN.STL.	AR
23	STUD	STN.STL.	AR
24	SPRING PACK ASSY (REVERSE)	IRON/STEEL	1
25	COVER-LOWER	Polyester Thermoset	1
26	SPRING (DIRECT ACTING ONLY)	STL.	1
27	NUT-HEX JAM	STN.STL.	1
28	SPINDLE (REVERSE)	STN.STL.	1
29	PLATE-ACTUATOR	DI.	2
30	PLUG	PLASTIC	1
31	ADAPTER	STN.STL.	1
32	EXTENSION-SPINDLE	STN.STL.	1
33	COVER-UPPER	Polyester Thermoset	1
34	DECAL-LABEL	MYLAR	1
35	PLATE-SUPPORT	STN.STL.	1
36	PIN-SPIROL	PLASTIC	1
37	SPRING-WAVE	-	1

Bill of Materials for Advantage[®] Actuators

Series 47 Actuators

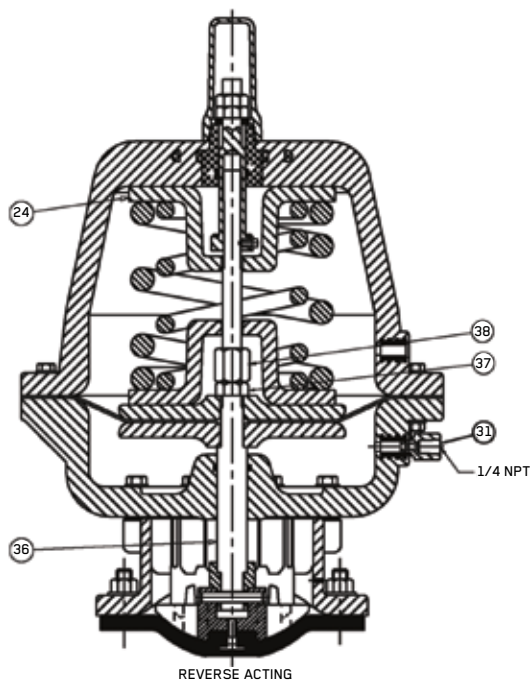
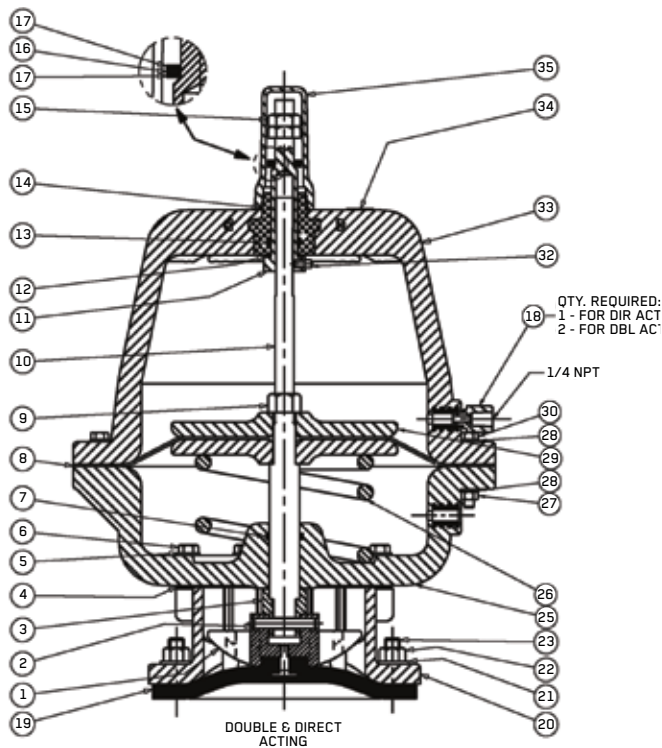

LIST OF PARTS			
ITEM	DESCRIPTION	MATERIAL	QTY.
1	COMPRESSOR	BRZ. OR CI.	1
2	PIN-SPIROL	STN. STL.	1
3	COLLAR-STOP	STN. STL.	1
4	GASKET	EPDM	1
5	WASHER-PLAIN	STN. STL.	8
6	SCREW-HEX HD CAP	CS.	8
7	O-RING	BUNA-N	1
8	DIAPHRAGM-ACTUATOR	BUNA-N	1
9	NUT-HEX	CS.	1
10	SPINDLE (DIRECT-DOUBLE)	STN. STL.	1
11	BUSHING-ADJUSTING	STN. STL.	1
12	WASHER-THRUST	NYLON	1
13	O-RING	BUNA-N	1
14	O-RING	BUNA-N	1
15	NUT-HEX JAM	STN. STL.	2
16	BEARING-THRUST	STL	1
17	RACS-THRUST	STL	2
18	ADAPTER	STN. STL.	AR
19	DIAPHRAGM-ELASTOMER	-	1
20	BONNET	DI. NYLON COATED	1
21	WASHER-PLAIN	STN. STL.	8
22	NUT-HEX	STN. STL.	8
23	STUD	STN. STL.	8
24	SPRING PACK ASSY (REVERSE)	IRON/STEEL	1
25	COVER-LOWER	Polyester Thermoset	1
26	SPRING*	STL.	1
27	NUT-HEX	STN. STL.	16
28	WASHER-PLAIN	STN. STL.	32
29	PLATE-ACTUATOR	DI.	2
30	SCREW	STN. STL.	16
31	ADAPTER	STN. STL.	1
32	PLUNGER-SPRING	STN. STL.	1
33	COVER-UPPER	Polyester Thermoset	1
34	DECAL-LABEL	MYLAR	1
35	CAP	ACRYLIC	1
36	SPINDLE (REVERSE)	STN. STL.	1
37	NUT-HEX JAM	STN. STL.	1
38	CPLG	STN. STL.	1

*Direct / Reverse Acting Only

Dimensional Data

Weir Valves with Advantage Actuators

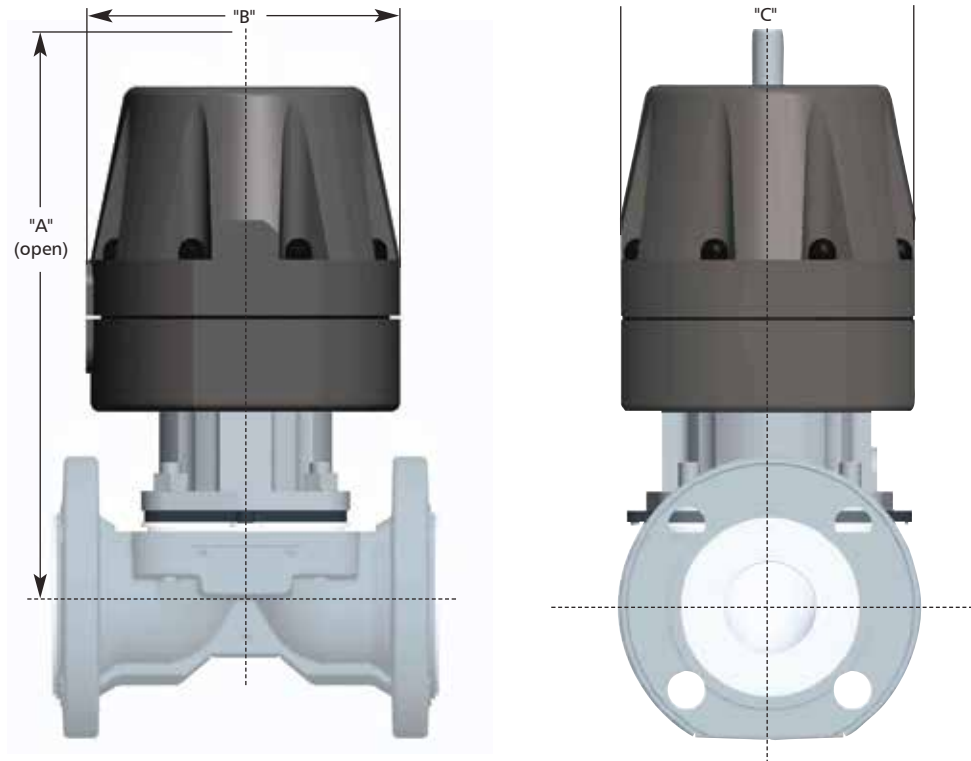

Body Size	Actuator Series	A (open)	B	C	Weight (lb) ⁵
0.50 ¹	5	5.25	3.34	3.00	2.2
0.50 ¹	8	5.84	4.55	3.88	3.4
0.75 ^{1,3}	8	6.38	4.55	3.88	3.6
1.00 ^{2,4}	8	6.96	4.55	3.88	4.1
1.00 ^{2,4}	16	9.78	6.41	5.94	12.9
1.25 & 1.50 ²	16	10.91	6.41	5.94	14.3
1.25 & 1.50 ²	33	15.21	10.57	10.57	41.8
2.00 ²	16	11.55	6.41	5.94	16.0
2.00 ²	33	15.59	10.57	10.57	46.4
3.00 ²	33	16.79	10.57	10.57	58.0
3.00 ²	47	21.75	14.00	14.00	96.0
4.00 ²	33	17.61	10.57	10.57	63.0
4.00 ²	47	23.23	14.00	14.00	99.0

1 = screwed body

2 = plastic lined body

3 = 0.75 topworks

4 = includes 0.75 body with 1.00 topworks

5 = reverse acting with bonnet

Note: dimensions for reference only, subject to change without prior notice. Contact factory for certified drawings.

Bill of Materials for Limit Switches

Microswitch
Limit Switches
LS1–LS6

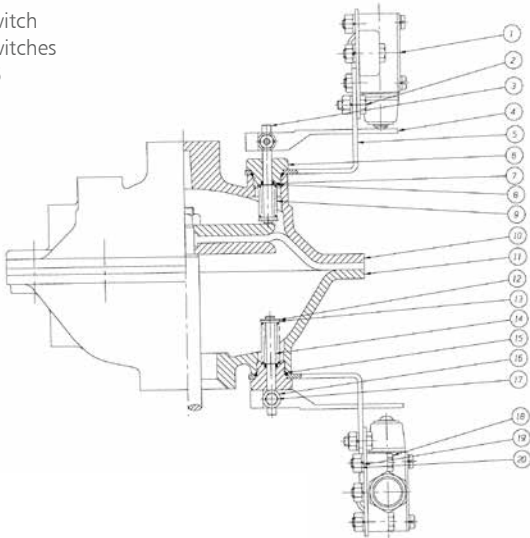

LIST OF PARTS			
ITEM	DESCRIPTION	MATERIAL	QTY
1	Switch, Limit – Model #BAF1	–	2
2	Screw, Hex. Hd. Cap	Steel	4
3	Rod, Operating	Stainless Steel	1
4	Switch, Actuator	Steel	2
5	Bracket, Switch Mounting	Steel	2
6	Guide, Rod	Brass	2
7	O-Ring #010	Buna-N	2
8	Ring, Retaining	Steel	2
9	Spring #90	Steel	2
10	Cover, (Upper)	Aluminum	1
11	Cover, (Lower)	Aluminum	1
12	Ring, Retaining	Steel	2
13	Washer, Plain	Steel	2
14	Rod, Operating	Stainless Steel	1
15	O-Ring #115	Buna-N	2
16	Washer, Plain	Steel	2
17	Screw, Machine Hex. Hd.	Steel	2
18	Screw, Hex. Hd. Cap	Steel	6
19	Washer, Lockspring	Steel	10
20	Nut, Hex.	Steel	10

Proximity
Limit Switches
LS9

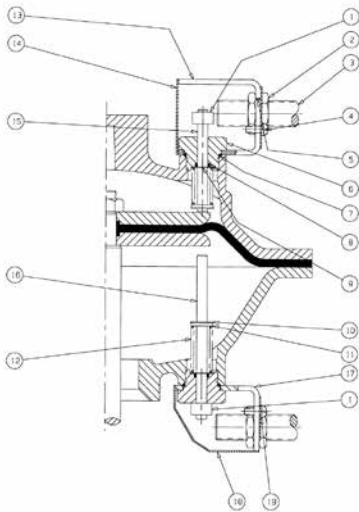

LIST OF PARTS			
ITEM	DESCRIPTION	MATERIAL	QTY
1	Collar, Set	Steel	2
2	Nut, Hex.	Steel	4
3	Switch, Proximity	–	2
4	Screw, Rd. Hd. Mach.	Steel	4
5	Insert, Switch, Proximity	Steel	2
6	Guide, Rod	Brass	2
7	O-Ring #115	Buna-N	2
8	O-Ring #010	Buna-N	2
9	Ring, Retaining	Steel	2
10	Ring, Retaining	Steel	2
11	Washer, Plain #10	Steel	1
12	Spring #90	Steel	2
13	Bracket, Switch Mounting	Steel	1
14	Cover, Bracket	Steel	1
15	Rod Operating	Stainless Steel	1
16	Rod Operating	Stainless Steel	1
17	Bracket, Switch	Steel	1
18	Cover, Bracket	Steel	1
19	Washer, Springlock	Steel	4

Westlock Module 3
Proximity Switch
LS8, LS11

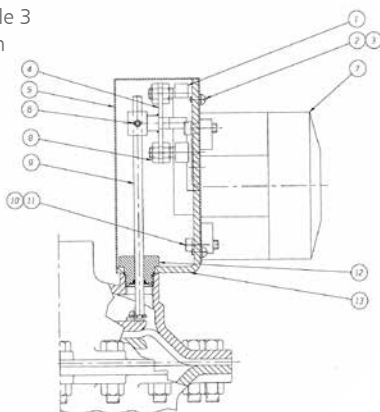

LIST OF PARTS			
ITEM	DESCRIPTION	MATERIAL	QTY
1	Trigger, Module-3 Hex. Hd.	Steel	2
2	Screw, Rd. Hd. Machine	Steel	4
3	Washer, Springlock	Steel	4
4	Actuator, Switch	Steel	1
5	Cover, Bracket	Steel	1
6	Screw, Set Soc. Hex.	Stainless Steel	1
7	Westlock #3479 Proximity Switch	–	1
8	Nut, Hex. Jam	Stainless Steel	4
9	Rod, Operating	Stainless Steel	1
10	Screw, Hex. Soc. Hd.	Steel	4
11	Washer, Springlock	Steel	4
12	Guide, Rod	Brass	1
13	Bracket, Switch	Steel	1

Bill of Materials for Positioners and Position Indicators

Moore Positioner
PR3, PR4 OR PR5
May be used on all
valve sizes.

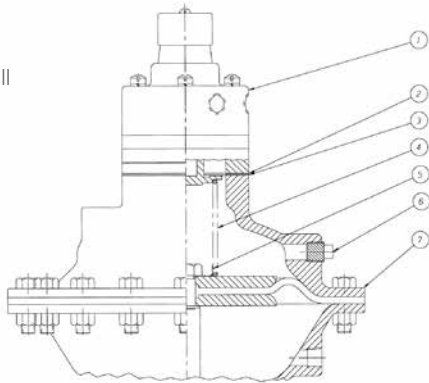

Positioners

LIST OF PARTS			
ITEM	DESCRIPTION	MATERIAL	QTY
1	Positioner, Moore	-	1
2	Ring, Diaphragm Modification	Brass	1
3	Gasket	Composition	1
4	Spring, Range	Steel	1
5	Spring Centering Device	Brass	1
6	Plug, Pipe Sq. Hd.	Steel	1
7	Cover, Actuator (Upper)	Aluminum	1

Conoflow Positioner PR1 or PR2
May be used on valve sizes
3/4" and larger.

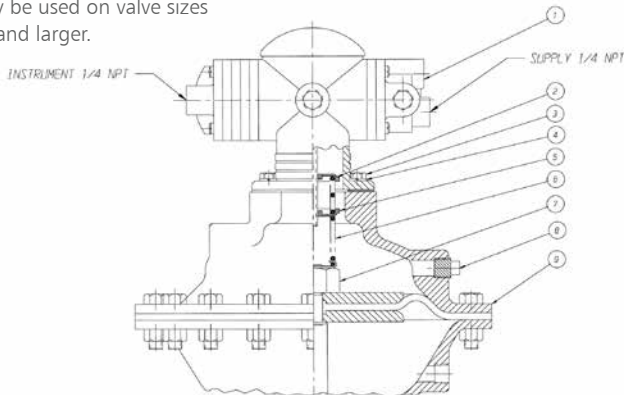

LIST OF PARTS			
ITEM	DESCRIPTION	MATERIAL	QTY
1	Positioner, Conoflow Commandaire	-	1
2	Clip, Upper Spring	Brass	1
3	Screw, Hex. Hd. Cap	Steel	6
4	Washer, Springlock	Steel	6
5	Clip, Lower Spring	Brass	1
6	Spring, Range	Steel	1
7	Assembly, Lock Nut	Steel	1
8	Plug, Pipe	Steel	1
9	Cover, Actuator (Upper)	Aluminum	1

#12 Air Motor

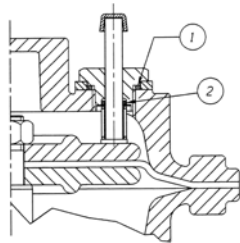

Position Indicators

LIST OF PARTS			
ITEM	DESCRIPTION	MATERIAL	QTY
1	O-Ring #113	Buna-N	1
2	O-Ring #010	Buna-N	1
3	Indicator Housing	Aluminum	1
4	O-Ring #110	Buna-N	2
5	Indicator Tube	Acrylic	1
6	Indicator Rod	Stainless Steel	1
7	Spacer	Steel	1
8	O-Ring #115	Buna-N	1
9	Retaining Ring	Steel	1
10	Magnet, Holding Crucible	-	1
11	Machine Screw	Steel	1
12	Cover, Actuator (Upper)	Aluminum	1

#25-#250 Air Motor

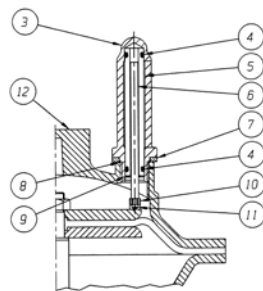

Bill of Materials for Dualrange

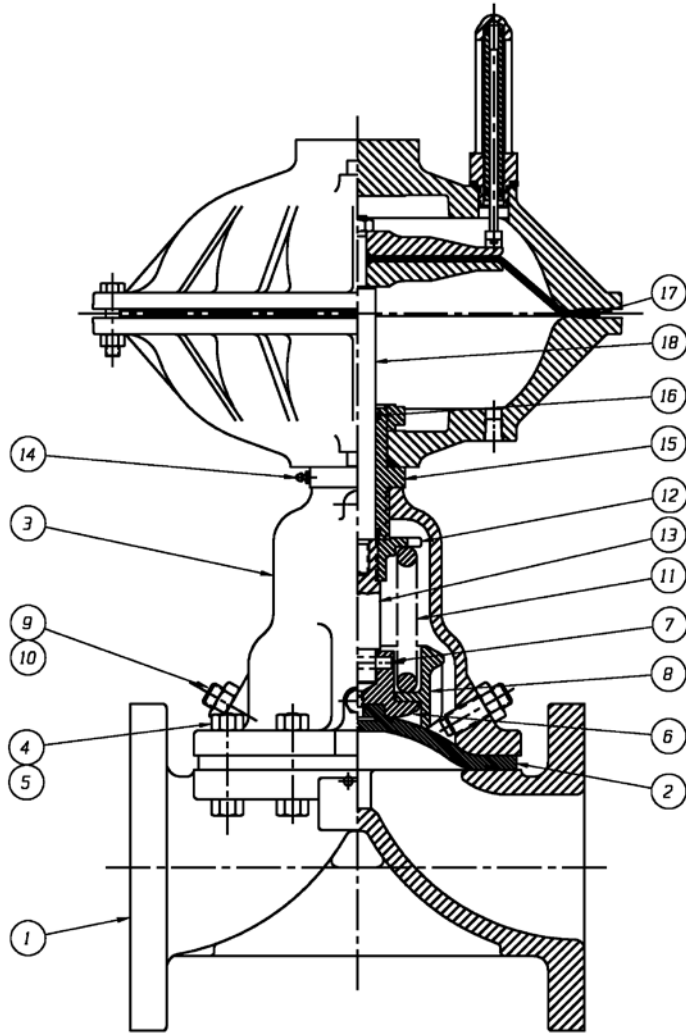

LIST OF PARTS			
ITEM	DESCRIPTION	MATERIAL	QTY.
1	BODY, FLANGED	-	1
2	DIAPHRAGM	-	1
3	BONNET, ADAPTER	DI.	1
4	SCREW, HEX. HD. CAP OR STUDS	-	8
5	NUTS, HEX.	-	8
6	COMPRESSOR, INNER	CI.	1
7	PIN, SPIRDL	STN. STL.	1
8	COMPRESSOR, OUTER	CI.	1
9	NUT, HEX. JAM	STN. STL.	2
10	SCREW, HEX. SOC. HD. SET	STEEL	2
11	SPRING	STEEL	1
12	NUT, SPRING	CI.	1
13	SPINDLE, LOWER	STEEL	1
14	FITTING, LUBE	-	1
15	BUSHING, ADAPTER	C. STL.	1
16	O-RING	BUNA-N	AR
17	DIAPHRAGM AIR MOTOR	BUNA-N	1
18	SPINDLE UPPER	STN STL	1

Flow Coefficients and Computations

The pipe size in the system ordinarily will determine the valve size. However, to assure accurate throttling or positioning, it is advisable to calculate the valve size. Formulas for liquid and gas are as follows:

Liquid Flow Formula*

$$C_v = Q_a \sqrt{sg/\Delta P}$$

$$Q_a = C_v \sqrt{\Delta P/sg}$$

$$\Delta P = sg(Q_a/C_v)^2$$

Where:

C_v = Flow Coefficient (gpm/ ΔP)

sg = Specific Gravity

Q_a = Actual Flow (gpm)

P = Actual Pressure Drop $P_1 - P_2$ (psi)

Gas Flow Formula*

$$C_v = Q/1360 \sqrt{sg(T)/\Delta P} \sqrt{2/(P_1 + P_2)}$$

$$Q = 1360 C_v \sqrt{\Delta P/sg(T)} \sqrt{(P_1 + P_2)/2}$$

$$\Delta P = P_1 - \sqrt{P_1^2 - (sg \times T)(Q/[963 \times C_v])^2}$$

Where:

Q = Volumetric flow (SCFH)**

sg = Specific gravity

T = Absolute Flowing Temperature ($^{\circ}F + 460$)

P_1 = Inlet Pressure (psia)

P_2 = Outlet pressure (psia)

ΔP = Pressure drop ($P_1 - P_2$)

C_v = Valve Coefficient from Tables

* Fluid Controls Institute Inc Standard FCI 62-1

** SCFH (standard cubic foot per hour) of gas is measured at 60° F (519.7R) and 14.696 psia. CFH (cubic foot per hour) is measured at any temperature and pressure.

Conversion of CFH to SCFH

$$SCFH = (P_{actual}/14.696) \times (519.7^{\circ}R/T_{actual}) \times CFH_{actual}$$

Where:

SCFH = Standard cubic feet per hour

P_{actual} = Pressure of gas in psia

T_{actual} = Temperature of gas ($^{\circ}F + 460$)

Note: The design of the Straightway Valves are not conducive to good throttling characteristics.

Important

In general, any reduction in outlet pressure below half the absolute inlet pressure will give no further increase in flow. The value of the ratio of pressure at which maximum flow is obtained varies somewhat depending on the actual fluid.

Flow Coefficients and Computations

Example Flow Computations

(flow at pressure drop of 1 psi)

Weir Valves

Problem: Find the rate of flow of water through a 1½" unlined cast iron flanged valve, half open, with a pressure drop of one psi.

Solution: From the 'Flanged End – Unlined' Weir Cv Table, the corresponding rate of flow is 42 gpm.

Problem: Find the valve position of 2½" 'Glass Lined valve table', with a water flow of 170 gpm and a pressure drop of 1 psi.

Solution: From the 'Glass Lined' valve table the corresponding valve position is 70% open.

Problem: Determine the flow in cubic feet per hour of air through a wide open 2 inch unlined valve. Inlet pressure at 60 psig, outlet pressure at 40 psig, and temperature at 60° F.

$$Q = (1360) (70) \sqrt{20/520} \sqrt{(74.7+54.7)/2}$$
$$Q = 150,400 \text{ SCFH}$$

Problem: Find the rate of flow of water through a 2½" soft rubber lined valve, half open with a pressure drop of 3 psi.

Solution: From 'Flanged End – Unlined' Weir Cv Table

$$C_v = 85 \text{ gpm}$$
$$Q_a = 85 \sqrt{3}$$
$$Q_a = 147 \text{ gpm}$$

Straightway Valves

Problem: Find the rate of flow of water through a 1½" unlined flanged valve, half open, with a pressure drop of 1 psi.

Solution: From Cv Table, the corresponding rate of flow is 72 gpm.

Problem: Find the valve position of a 2½" rubber lined valve, with a water flow of 285 gpm and a pressure drop of 1 psi.

Solution: From Cv Table, the corresponding valve position is 70% open.

Problem: Find valve size and valve position of an unlined valve, with flow at 200 gpm and an actual pressure drop of 5 psi for a liquid with a specific gravity of 1.8.

Solution:
 $C_v = 200 \sqrt{1.8/5} = 200 \sqrt{.36} = (200)(0.6) = 120$
From Cv Table: A 2" valve has a Cv of 120 at 40% open.

Problem

Determine the flow in cubic feet per hour of air through a wide open 2" unlined valve. Inlet pressure at 60 psig, outlet pressure at 40 psig, and temperature at 60° F.

Solution: From Cv Table: $C_v = 275$
 $Q = 1360 (275) \sqrt{20/([1][520])} \sqrt{(74.7+54.7)/2}$
 $= 374,000 \sqrt{.04} \sqrt{64.7} = 374,000 \times 1.61$
 $Q = 602,140 \text{ Standard Cubic Feet per Hour}$

Problem: Find the rate of flow of water through a 2½" #5 rubber lined valve, full open, with a pressure drop of 3 psi.

Solution: From Cv Table, $C_v = 365$
 $Q_a = 365 \sqrt{3}$ or 632 gpm

Problem: Find the pressure drop across a 1½" plastic lined valve 100% open with water flow of 63 gpm

Solution From Cv Table, $C_v = 80$
 $\Delta P = (63/80)^2 = 0.62 \text{ psi}$

Flow Coefficients and Computations

Fluid velocity is a very important design consideration when selecting diaphragm valves. As mentioned previously velocity should be limited to 15–20 fps for clean fluids and 8–10 fps for slurries. Velocity through a Dia-Flo® weir type diaphragm valve can be determined by using the following equation:

$$V = .321 (Q/A)$$

Where:

V = Velocity in feet per second

Q = Flow in gallons per minute

A = Area in square inches at the point of greatest restriction (from table below)

Area Over the Weir for Standard Weir Valves (Square Inches)										
Valve Size	% OPEN									
	10	20	30	40	50	60	70	80	90	100
1/2	.03	.06	.08	.10	.12	.14	.16	.18	.19	.20
3/4	.06	.11	.16	.20	.24	.28	.31	.34	.37	.39
1*	.09	.18	.26	.33	.40	.46	.52	.57	.62	.65
1 1/4, 1 1/2	.23	.43	.62	.79	.95	1.11	1.24	1.37	1.48	1.56
2	.38	.73	1.05	1.33	1.61	1.87	2.10	2.31	2.50	2.64
2 1/2	.55	1.05	1.51	1.93	2.33	2.71	3.05	3.35	3.62	3.83
3	.84	1.60	2.30	2.93	3.53	4.11	4.62	5.08	5.50	5.81
4	1.37	2.62	3.76	4.81	5.78	6.73	7.57	8.33	9.01	9.51
6	3.0	5.7	8.1	10.4	12.5	14.5	16.3	18.0	19.5	20.5
8	5.8	11.2	16.1	20.5	24.7	28.7	32.3	35.5	38.4	40.6
10	8.4	16.1	23.1	29.5	35.5	41.3	46.5	51.1	55.3	58.4
12	11.8	22.6	32.4	41.4	49.8	58.0	65.2	71.7	77.5	81.9

Area Over the Weir for DualRange® Valves (Square Inches)										
Valve Size	% OPEN									
	10	20	30	40	50	60	70	80	90	100
1**	.06	.11	.14	.18	.25	.31	.38	.49	.62	.65
1 1/2"	.10	.21	.28	.34	.44	.59	.80	1.00	1.22	1.56
2"	.14	.22	.37	.63	.98	1.26	1.57	1.91	2.11	2.64
2 1/2"	.14	.39	.63	.88	1.31	1.86	2.27	2.67	3.25	3.83
3"	.30	.65	.98	1.29	1.94	2.51	3.35	3.99	4.65	5.81
4"	.60	1.14	1.62	2.63	4.01	4.92	5.95	6.81	7.85	9.51
6"	1.54	2.30	4.01	6.63	9.43	11.68	13.79	15.84	17.90	20.50

* Includes all 3/4" flanged valves except solid plastic

Flow Coefficients and Computations

Weir Valve Cv Ratings

		Flanged End – Unlined										
%	open	1/2	3/4-1	1 1/4 & 1 1/2	2	2 1/2	3	4	6	8	10	12
10	0.5	3	11	12	17	30	39	105	200	320	550	
20	0.7	7	21	26	41	55	92	210	400	655	950	
30	1.0	11	29	39	68	85	145	315	575	1000	1275	
40	1.5	14	36	49	90	115	200	415	750	1300	1600	
50	2.0	18	42	56	115	135	265	480	900	1450	1875	
60	3.0	20	46	62	140	155	285	520	975	1625	2100	
70	3.5	21	50	66	150	165	290	550	1050	1725	2250	
80	4.0	22	52	69	155	175	300	570	1125	1775	2375	
90	5.0	22	54	70	160	185	305	590	1175	1800	2475	
100	5.5	22	56	70	160	190	310	600	1200	1800	2550	

		Flanged End – Hard Rubber Lined										
%	open	1/2	3/4-1	1 1/4 & 1 1/2	2	2 1/2	3	4	6	8	10	12
10	0.2	2.9	12	15	20	31	46	150	225	320	400	
20	0.4	5.4	22	30	35	57	105	275	450	655	750	
30	0.7	8.2	26	40	50	75	160	375	650	1000	1125	
40	1.2	11	28	45	65	93	210	475	800	1300	1425	
50	1.5	13	29	50	80	110	220	550	900	1425	1700	
60	2.0	13	29	54	90	130	230	600	975	1550	1900	
70	2.4	13	30	60	100	145	245	610	1050	1650	2075	
80	2.8	12	30	60	110	155	250	620	1075	1700	2200	
90	3.4	11	31	59	115	160	260	625	1125	1750	2300	
100	4.0	10	31	55	115	160	260	625	1150	1750	2350	

		Flanged End – Soft Rubber Lined										
%	open	1/2	3/4-1	1 1/4 & 1 1/2	2	2 1/2	3	4	6	8	10	12
10	0.5	2.0	12	16	20	27	55	110	225	320	400	
20	0.5	3.1	19	26	40	48	105	225	450	655	750	
30	0.7	4.5	23	35	55	66	155	330	650	1000	1125	
40	1.0	5.5	25	46	70	83	195	430	800	1300	1425	
50	1.0	6.2	26	51	85	100	220	465	900	1425	1700	
60	1.5	6.9	26	53	95	117	230	480	975	1550	1900	
70	2.0	7.1	26	54	105	133	235	495	1050	1650	2075	
80	2.0	7.2	26	54	110	144	240	505	1075	1700	2200	
90	2.0	7.1	25	52	110	150	245	510	1125	1750	2300	
100	2.0	7.0	25	50	110	155	250	515	1150	1750	2350	

		Flanged End – PFA Lined						
%	open	1/2"	3/4", 1"	1-1/2"	2"	3"	4"	6"
10	0.05	0.1		3	6	13	22	26
20	0.2	1.9		8	12	39	63	139
30	0.8	2		12	20	70	108	326
40	1.4	5		17	27	104	142	397
50	2	7		21	34	116	160	459
60	2.3	8		25	39	130	174	504
70	2.5	9		27	45	134	185	523
80	2.7	10		29	48	142	191	525
90	2.9	10		30	50	144	199	528
100	3	10		30	51	145	202	530

		Flanged End – Plastic Lined (except PFA)							
%	open	3/4-1	1 1/4 & 1 1/2	2	2 1/2	3	4	6	8
10	3	5	10	17	40	60	105	390	
20	5	15	23	40	70	120	265	600	
30	7	25	37	61	100	170	400	740	
40	8	31	50	82	120	210	505	830	
50	9	36	65	94	140	245	585	900	
60	10	38	68	98	150	265	630	960	
70	11	39	69	99	160	280	670	1000	
80	11	40	69	100	170	285	680	1040	
90	10	39	69	100	175	290	685	1060	
100	10	38	67	100	175	285	690	1070	

Cv rating

Rate of flow depends upon the pressure drop.

Cv is the amount of flow in gallons per minute through a valve which results in a 1 psi pressure drop. Throttling characteristics are shown in the same manner with Cv's at various openings. Use formula shown below to compute actual flow at various pressure drops.

$$\text{Actual Flow (gpm)} = C_v \sqrt{\Delta P / s_g}$$

Flow Coefficients and Computations

Weir Valve Cv Ratings

%	Glass Lined									
	open	1/2	3/4-1	1 1/4 & 1 1/2	2	2 1/2	3	4	6	8
10	0.5	1.4	10	11	17	24	32	160	280	
20	0.7	4.4	19	25	41	60	63	315	560	
30	1.0	8.0	27	42	72	100	130	455	840	
40	1.5	12	36	56	96	140	200	590	1125	
50	2.0	15	45	72	120	180	265	685	1350	
60	3.0	19	51	80	150	215	320	760	1525	
70	3.0	22	54	83	170	235	365	805	1625	
80	3.5	22	55	83	175	240	400	835	1675	
90	4.5	22	54	82	180	245	415	845	1700	
100	5.5	22	53	78	180	250	420	850	1700	

%	Screwed End Metal							
	open	1/2	3/4	1	1 1/4 & 1 1/2	2	2 1/2	3
10	0.4	2	3	9	12	20	78	
20	0.6	3	6	16	26	37	110	
30	1.0	5	8	24	39	52	128	
40	1.4	6	10	30	49	65	140	
50	1.6	7	12	36	56	75	146	
60	2.0	8	14	40	62	83	150	
70	2.6	8	16	44	66	89	156	
80	3.0	10	17	47	69	94	161	
90	3.8	10	18	48	70	96	166	
100	4.4	10	19	48	70	95	172	

%	Solid Plastic								
	open	1/2	3/4	1	1 1/4	1 1/2	2	3"	4"
10	0.20	0.60	0.80	1.20	1.80	6.0	19	34	
20	0.50	2.20	3.40	4.00	9.20	12.20	43	60	
30	0.90	4.00	6.20	9.80	16.00	24.50	68	82	
40	1.80	5.60	8.20	16.00	21.80	38.50	92	103	
50	2.50	7.00	10.50	20.90	27.20	49.50	106	124	
60	2.90	7.70	12.80	25.30	31.50	57.00	118	144	
70	3.20	8.20	14.30	26.40	31.50	60.00	122	160	
80	3.40	8.40	15.20	27.10	31.50	62.60	124	172	
90	3.60	8.70	15.80	27.70	31.50	64.00	125	179	
100	3.60	8.70	15.80	28.40	31.50	65.50	125	185	

%	Butt Weld										
	open	1/2"	3/4"	1"	1 1/2"	2"	2 1/2"	3"	4"	6*	8*
10	0.2	2.0	3.0	9	12	20	30	32	105	200	
20	0.4	3.1	6.0	16	26	37	55	70	210	400	
30	0.7	4.5	8.0	24	39	52	85	130	315	575	
40	1.2	5.5	10.0	30	49	65	115	200	415	750	
50	1.5	6.0	13.0	36	56	75	135	265	480	900	
60	2.0	6.4	14.0	40	62	83	155	290	520	975	
70	2.4	6.8	16.0	44	66	89	165	320	550	1050	
80	2.8	7.0	17.0	47	69	94	170	360	570	1125	
90	3.0	7.2	18.0	48	70	95	175	385	590	1175	
100	3.5	7.5	18.6	48	70	95	180	400	600	1200	

Cv ratings applying to screwed end metal and flanged unlined valves are based on use of cast iron bodies. For socket weld metal bodies, use Butt weld Cv Table.

Flow Coefficients and Computations

Dualrange® Control Valves Cv Ratings

%	Flanged – Unlined						
	3/4-1	1½	2	2½	3	4	6
open							
10	1.0	2.0	4.0	8.0	14	24	65
20	3.2	8.0	9.0	18	27	47	125
30	5.2	14	14	28	42	70	255
40	7.4	21	19	52	68	130	365
50	9.4	33	33	78	97	185	445
60	13	43	50	105	120	245	515
70	18	50	62	130	145	275	550
80	21	52	69	150	160	295	570
90	22	54	70	160	175	305	590
100	22	56	70	160	190	310	600

%	Flanged – Plastic Lined (except PFA)						
	3/4-1	1½	2	2½	3	4	6
open							
10	1.0	3.0	4.5	7.0	16	20	70
20	2.8	8.0	11	17	34	55	145
30	4.7	13	16	28	52	80	280
40	6.6	21	27	50	84	125	430
50	8.2	32	43	75	125	190	540
60	9.5	37	60	88	150	240	610
70	10	38	68	97	160	270	655
80	11	39	69	100	170	285	680
90	10	38	69	100	175	290	690
100	10	38	67	100	175	285	690

%	Flanged – Soft Rubber Lined						
	3/4-1	1½	2	2½	3	4	6
open							
10	0.5	3.0	3.5	6.0	12	22	65
20	1.6	8.0	10	15	26	41	125
30	3.2	14	17	25	39	60	250
40	5.5	20	23	47	55	105	350
50	6.2	29	33	76	77	155	405
60	6.9	28	47	95	99	195	450
70	7.1	26	54	105	120	220	485
80	7.2	26	54	110	135	240	505
90	7.1	25	52	110	145	245	510
100	7.0	25	50	110	155	250	515

%	Flanged – Hd Rubber Lined						
	3/4-1	1½	2	2½	3	4	6
open							
10	0.5	3.5	6.0	10	12	25	65
20	3.0	10	12	20	26	50	130
30	5.9	16	17	30	40	71	275
40	8.3	26	22	49	57	130	430
50	10	29	37	65	84	190	530
60	11	29	51	84	110	230	570
70	11	30	60	96	125	245	590
80	11	30	60	105	145	250	620
90	10	31	59	110	155	260	625
100	10	31	55	115	160	260	625

%	Flanged – Glass Lined						
	3/4-1	1½	2	2½	3	4	6
open							
10	1.4	3.0	3.0	8.0	12	24	98
20	3.8	9.0	9.0	18	32	50	190
30	6.2	16	17	28	48	77	370
40	8.6	26	25	56	84	145	520
50	12	40	40	85	135	210	640
60	18	51	62	115	185	270	750
70	22	54	75	140	220	335	805
80	22	55	82	155	240	395	835
90	22	54	82	180	245	415	845
100	22	53	78	180	250	420	850

%	Flanged End – PFA Lined					
	1"	1.5"	2"	3"	4"	6"
open						
10	0.1	1.8	2.7	5	7	17
20	1	4.3	5.7	19	29	55
30	1.3	6.2	8.7	36	51	228
40	4.2	11.5	15	73	84	338
50	6.4	19	22	104	124	424
60	7.6	24	34	130	158	488
70	8.2	26	44	134	178	511
80	10	28	48	142	191	525
90	10	29	50	144	199	530
100	10	30	51	145	202	530

Flow Coefficients and Computations

Straightway Valve Cv Ratings

% open	Flanged Plastic Lined						
	1	1½	2	3	4	6	8**
10	0.6	5	9.3	40	80	162	227
20	5.6	21	38	97	167	398	619
30	14	42	76	158	252	587	864
40	17	48	96	200	322	733	1080
50	18	54	116	215	334	818	1245
60	20	58	123	236	372	862	1262
70	23	65	137	270	424	963	1372
80	24	73	156	292	474	1052	1535
90	24	80	180	320	525	1191	1917
100	24	80	209	370	569	1400	2644

% open	FLG - #5*		
	1	1½	2
10	15	16	22
20	24	26	40
30	28	36	90
40	32	48	135
50	34	59	150
60	36	64	150
70	38	66	155
80	40	69	165
90	41	73	190
100	42	79	220

% open	FLG - #10*		
	1	1½	2
10	6.5	15	36
20	15	30	72
30	23	48	130
40	30	62	140
50	35	72	160
60	40	80	180
70	44	90	200
80	47	100	220
90	50	115	240
100	55	130	260

% open	Flanged Rubber Lined							
	2½	3	4	6	8	10	12	
10	60	65	90	100	350	550	550	
20	110	125	185	275	700	1150	1150	
30	155	190	255	550	1050	1700	1700	
40	190	235	310	825	1400	2250	2250	
50	215	270	350	950	1750	2800	2800	
60	235	290	415	1000	2150	3100	3100	
70	245	315	525	1050	2500	3200	3200	
80	260	350	645	1100	2875	3300	3300	
90	285	390	685	1300	3200	3650	3650	
100	365	460	700	1800	3500	4850	4850	

% open	Flanged End Unlined									
	1	1½	2	2½	3	4	6	8	10	12
10	10	15	30	60	75	85	250	350	450	450
20	19	30	60	115	135	165	450	700	1050	1050
30	26	45	90	160	185	240	700	1030	2000	2000
40	32	60	120	205	230	320	950	1400	2800	2800
50	38	72	150	240	270	400	1150	1750	3350	3350
60	44	80	180	265	295	480	1400	2050	3550	3550
70	48	84	210	285	310	560	1650	2350	3650	3650
80	52	87	235	300	335	625	1850	2700	3900	3900
90	56	97	260	350	390	670	2050	3300	4300	4300
100	60	115	275	450	525	700	2250	4250	5000	5000

* Flanged #10 = hard natural rubber lining. Flanged #5 = soft natural rubber, neoprene and butyl linings.

** Data is based on estimates.

Flow Coefficients and Computations

Specific Gravities of Gases Related to Free Air (Free air = Air at 1 atmosphere and 60° F)			
Gas	Specific Gravities (Air = 1)	Gas	Specific Gravities (Air = 1)
Acetylene	0.899	Hydrogen Sulphide	1.190
Air	1.000	Methane	0.544
Ammonia	0.590	Methyl Chloride	1.744
Argon	1.378	Natural Gas	0.57—0.71
Blast-Furnace Gas	1.000	Neon	0.696
Blue Water Gas	0.530	Nitric Oxide	1.038
Carbon Dioxide	1.530	Nitrogen	0.970
Carbon Monoxide	0.967	Nitrous Oxide	1.522
Carbureted Water Gas	0.640	Oil Gas	0.480
Chlorine	2.486	Oxygen	1.105
Coal – Retort Gas	0.420	Pintsch Gas	0.840
Coke – Oven Gas	0.380	Producer Gas, Coal	0.870
Dichlorodifluoromethane F-12	4.250	Propane	1.560
Ethylene	0.969	Refinery Gas:	
Ethyl Chloride	2.260	Dubbs	0.960
Helium	0.138	Houdrie	1.510
Hydrochloric Acid	1.260	Sulphur Dioxide	2.213
Hydrogen	0.0696		

Strength % by Weight	Specific Gravities					Strength % by Weight
	HCl. Hydrochloric Acid	HNO ₃ Nitric Acid	H ₂ SO ₄ Sulphuric Acid	KOH Caustic Potash	NaOH Caustic Soda	
5	1.0251	1.0270	1.0332	1.041	1.058	5
10	1.0503	1.0561	1.0681	1.083	1.115	10
15	1.0754	1.0865	1.1045	1.128	1.170	15
20	1.1005	1.1178	1.1424	1.177	1.225	20
25	1.1257	1.1503	1.1816	1.230	1.279	25
30	1.1508	1.1838	1.2220	1.288	1.332	30
35	1.1759	1.2183	1.2636	1.349	1.384	35
40	1.2000	1.2511	1.3065	1.411	1.437	40
45	–	1.2836	1.3515	1.472	1.488	45
50	–	1.3157	1.3990	1.539	1.540	50
60	–	1.3734	1.5024	–	–	60
70	–	1.4210	1.6151	–	–	70
80	–	1.4601	1.7323	–	–	80
90	–	1.4941	1.8198	–	–	90

Service Guide

Introduction

Data, recommendations, and suggestions contained herein are based on experiences in actual field applications as well as common corrosion data. However, because of so many possible variances in practices from plant to plant, these recommendations are intended for use only as a guide and should not be interpreted as a guarantee. It is recommended that tests be conducted under actual or simulated use conditions wherever possible to determine suitability of materials for a specific application.

Selections in the following pages have been made with safety and serviceability as the foremost considerations. Many variables enter into the question of serviceability. Factors such as concentration, temperature, pressure, velocity, percent solids, temperature cycling, vacuum, cleaning practices, etc. are all important in determining whether or not a particular material will give satisfactory service.

Of the endless number of chemical compounds, many are insoluble in water and would consequently cause no corrosion problems when in water. However, some of these simple services can become difficult when it is necessary to make such materials soluble through use of some other solvent. For example, sulfuric acid is commonly used as a solvent for silver chloride. Then, the recommendation must take into account both silver chloride and sulfuric acid.

Diaphragms

Selection of the diaphragm material is the most important consideration in specifying a diaphragm valve. The most important qualities are:

- Capable of withstanding more than maximum valve pressure rating
- Capable of giving good service life at maximum temperatures
- Long economical flex life at maximum pressure and temperature
- Ability to withstand the compression of thousands of valve closures
- Chemical resistance
- Non-contaminating to the pipeline fluid

Diaphragm valves are extremely versatile and are used on thousands of services, each differing with respect to media, temperature, velocity, concentration, percent solids, pressure, etc. As new developments in chemical applications and elastomer and plastic materials occur, continuing research and development results in substantial product improvements and increased service life for diaphragm valves.

Rigid standards enforced by tests conducted on every batch of diaphragms produced ensure consistently high quality. This close control has produced diaphragms which in many services last years – important years of savings because of maintenance-free operation.

Body Material Selection

As a general rule, it is recommended that pipeline or tank material be used for the valve body whenever possible. This is particularly important when using metal screwed end valve bodies because of galvanic corrosion. Also, because of diaphragm valve design, whatever is suitable for the pipeline or tank is also usually suitable for the valve body. However, certain throttling or control valves may require a more sophisticated material for the valve body than the pipe due to velocity or pressure drop conditions being more severe in the valves.

In cases when more than one material is satisfactory for the particular service, it is usually best for the user to make a selection based on previous experience and possible variances in individual plant practices.

Notes

- Generally, where cast iron is recommended for a service, ductile iron and cast steel will also be satisfactory.
- For similar compounds such as Potassium and Sodium, normally the same material is suitable for either service. (This is generally true of compounds of other metals on the upper end of the electromotive series.)
- Where abrasion resistant materials or linings are required, a soft resistant lining similar to a soft natural rubber should be used on abrasive mixtures of sand, silt and / or mineral particulate matter; where abrasive fluids contain sharp jagged particles such as iron filings or glass, it may be more desirable to use *hard* resistant materials including stainless steel, iron or tough linings such as ETFE or PVDF. Plastic diaphragms, especially PTFE, are not generally recommended for abrasive services.

Service Guide

Diaphragm selection¹

Valve	Grade	Material	Size ⁵	Typical Services	Temp °F ^{2,4}		Temp °C ^{2,4}	
					Min	Max	Min	Max
Weir Type Elastomers	B	Black Butyl	1/2"-12"	Chemicals, gases, stronger acids	-20	250	-29	121
	M	Ethylene Propylene (EPDM)	1/2"-12"	Chemicals, acids, hi-temp, abrasives	-30	300	-34	149
	E1	EPDM Compound E1 (FDA)	1/2"-8"	Beverages, pharmaceuticals	-30	300	-34	149
	DP	Buna N	1/2"-3"	For direct load valve	10	180	-12	82
	P	Buna N	1/2"-12"	Foods, oils	10	180	-12	82
	S	Natural Rubber	1/2"-8"	Water, abrasives	-30	180	-34	82
	T	Neoprene	1/2"-12"	Weak chemicals, air, oil resistant	-20	200	-29	93
	V	Viton	1/2"-6"	Specific solvents & chemicals, oils	-20	325	-29	163
	W1	White Butyl	1/2"-6"	Foods, beverages, pharmaceuticals	0	225	-18	107
	Weir Type Plastics ³	TM	Modified PTFE	1/2"-6"	Severe chemicals, solvents	-30	350	-34
R2		Polytetrafluoroethylene (PTFE)	8"-10"	Severe chemicals, solvents	-30	350	-34	177

Notes: ¹ To be used as general guide; for complete service guide see following pages.

² Diaphragms at maximum temperature cannot be used satisfactorily at maximum pressures. Pressure / temperature charts are provided on the following pages.

³ With ethylene propylene backing cushion.

⁴ Cast Iron, Ductile Iron and Carbon Steel should not be used below -20° F (-29° C).

⁵ See following pages for DN equivalent.

Diaphragm Correlation

Recommended Material	Weir Code	Straightway Code
EPDM	M, E1	SE
EPDM - FDA	E1	SE
Butyl	B	SB
White Butyl	W1	--
Hypalon	C	SC
Neoprene	T	ST
Natural Rubber	S	SS
Nitrile, Buna N	P, DP	SP
Viton	V	--
PTFE	TM, R2	--

Service Guide

Chlorine (Cl₂)

Dry or anhydrous chlorine can be either a gas or a liquid. Diaphragm valves are not recommended for dry chlorine. Only Chlorine Institute approved valves such as the Cam-Tite® Ball Valve should be used for handling dry chlorine. Diaphragm valves are not Chlorine Institute recommended.

Wet Chlorine Gas

Wet chlorine gas is extremely corrosive and will eventually permeate even PTFE diaphragms. Valve bodies are usually PDVF lined, ETFE lined, or hard rubber lined (#12) with grade R-2 or TM (PTFE) diaphragms. Sealed bonnets are recommended as well as a continuing maintenance and inspection program.

Chlorine Water Solutions

These chlorine solutions are formed when low pressure chlorine gas is bubbled into water. Diaphragm valves are widely used on these solutions. A surface film of rubber hydrochloride will form on soft rubber on exposure to wet chlorine gas or chlorine water solutions. This film stops further attack but repeated flexing of a soft rubber diaphragm will continue to crack the film, eventually destroying the diaphragm. PTFE diaphragms are usually preferred for strong solutions and frequent flexing.

Sulfuric Acid (H₂SO₄)

Sulfuric acid is an inorganic mineral acid very widely used in industry. It is dense, oily and very corrosive. Since the rate of chemical attack of sulfuric acid is directly related to its concentration and temperature, it is vital that both of these factors be considered when specifying valves for sulfuric acid service. Diaphragm valves lined with ETFE using PTFE diaphragms will withstand any concentration of sulphuric acid at temperatures up to and exceeding 200° F. Many other materials can also be utilized for sulfuric acid depending on temperature and concentration.

Hydrochloric Acid (HCl)

Hydrochloric acid, also called muriatic acid, is an inorganic mineral and widely used in industry. When in contact with most metals, HCL causes the evolution of hydrogen gas which can form explosive mixtures with air. As a result hydrochloric acid is seldom used with metals other than special alloys such as Hastelloy B and Tantalum.

The best and most widely used piping materials for handling hydrochloric acid include various rubbers, plastics and glass. As with most corrosive agents, temperature and concentration are very important considerations. Diaphragm valves offer a very broad range of body linings and diaphragm materials and can handle all concentrations of hydrochloric acid at temperatures up to 300° F.

Sodium Hydroxide (NaOH)

Sodium hydroxide, also called caustic soda, is widely used in industry dissolved in water to form liquid caustic soda. Valves with stem packings are usually avoided in sodium hydroxide service because the solutions aggressively attack conventional stem packing materials. Ball valves and plug valves on caustic soda service should be steam traced, otherwise the solution may crystallize within the ball or plug, expand and overstress the valve. Diaphragm valves do not present this problem.

Diaphragm valves are widely used in sodium hydroxide service. Cast iron or ductile iron valves with neoprene diaphragms give excellent service under ambient temperature conditions. Where it is important to avoid rust and iron contamination, stainless steel or plastic lined valves should be specified.

Phosphoric Acid (H₃PO₄)

Phosphoric acid is an inorganic acid, widely used in fertilizers, food preparation, pharmaceuticals and other industrial services. The concentration of phosphoric acid is normally expressed as % P₂O₅ (percent phosphoric anhydride) rather than % H₃PO₄ (percent phosphoric acid). Percent phosphoric acid equals 1.38 times % P₂O₅. Therefore 75% phosphoric acid = 54.3% P₂O₅. Aqueous solutions of phosphoric acid have crystallizing points and therefore temperatures must be maintained to keep the solutions fluid.

Materials of construction include stainless steel (316), rubber and plastic linings, and diaphragms of Butyl, EPDM and Neoprene. Neoprene lined straightway valves with Neoprene or EPDM diaphragms are widely used in handling highly abrasive phosphoric acid slurries.

Hydrofluoric Acid (HF)

Anhydrous (dry) hydrogen fluoride (HF) is a gas at room temperature and pressure. When dissolved in water, it yields hydrofluoric acid. Aqueous HF is produced in concentrations of 30–80%. The boiling point varies with the concentration, being 230° F for 30% HF and 119°F for 80% HF.

Do not use glass or ceramics in handling HF. At concentrations above 48%, valves lined with ETFE or PVDF are recommended and diaphragms of Grade R-2 or TM (PTFE) should be used.

Index by Chemical Formula

AgCl	Silver Chloride	COOH(CHOH) ₂ COOH	Tartaric Acid
AgCN	Silver Cyanide	(COOH) ₂ • 2H ₂ O	Oxalic Acid
AgI	Silver Iodide	HOOCCH ₂ C(OH)(COOH)CH ₂ COOH • H ₂ O	Citric Acid
AgNO ₃	Silver Nitrate	(CH ₃ CO) ₂ O	Acetic Anhydride
AlCl ₃	Aluminum Chloride	C ₆ H ₄ (CO) ₂ O	Phthalic Anhydride
AlK(SO ₄) ₂ • 12H ₂ O	Potassium Alum	CCl ₄	Carbon Tetrachloride
AlNH ₄ (SO ₄) ₂ • 12H ₂ O	Ammonium Alum	C ₂ Cl ₄	Perchloroethylene
Al ₂ O ₃ • 3H ₂ O	Alumina Trihydrate	(ClC ₆ H ₄) ₂ CHCCl ₃	DDT
Al ₂ (SO ₄) ₃ • 18H ₂ O	Aluminum Sulfate	C ₂ H ₅ Br	Ethyl Bromide
BaSO ₄	Barium Sulfate	CHCl ₃	Chloroform
Br + H ₂ O	Bromine Water	CH ₂ Cl ₂	Methylene Chloride
CaCl ₂	Calcium Chloride	C ₂ H ₄ Cl ₂	Ethylene Dichloride
CaCO ₃	Calcium Carbonate	CHClCCl ₂	Trichloroethylene
Ca(HSO ₃) ₂	Calcium Bisulfite	CH ₂ CHCl	Vinyl Chloride Monomer
CaO	Calcium Oxide	(-CH ₂ CHCl-) _n	PVC
Ca(OH) ₂	Calcium Hydroxide (Lime)	CH ₂ OCHCH ₂ Cl	Epichlorhydrin
Ca(OCl) ₂	Calcium Hypochlorite	C ₆ H ₆	Benzene
CaSO ₄	Calcium Sulfate	C ₆ H ₁₄	Hexane
CaSO ₄ • 2H ₂ O	Gypsum	C ₆ H ₅ CH ₃	Toluene
Cl ₂	Chlorine	C ₆ H ₄ (CH ₃) ₂	Xylene
ClO ₂	Chlorine Dioxide	C ₆ H ₅ CHCH ₂	Styrene
CH ₂ C(CH ₃)COOCH ₃	Ethylene Oxide	C ₄ H ₁₀ O ₂	Ethyl Cellosolve
CH ₂ CHCN	Acrylonitrile	C ₂ H ₂	Acetylene
CH ₃ C ₆ H ₂ (NO ₂) ₃	Trinitrotoluene (TNT)	C ₃ H ₈	Propane
C ₆ H ₄ (COOC ₄ H ₉) ₂	Dibutyl Phthalate	C ₄ H ₁₀	Butane
CH ₂ NO ₃ CHNO ₃ CH ₂ NO ₃	Nitroglycerine or Trinitro	CH ₂ CHCHCH ₂	Butadiene
(C ₂ H ₅) ₂ O	Ether	CO ₂	Carbon Dioxide
C ₂ H ₆ O ₂	Methyl Methacrylate Slurry	(CH ₃) ₂ CHCH ₂ COCH ₃	Methyl Isobutyl Ketone
(-CH ₂ -O-) _n	Acetal Resin Slurry	CH ₃ COCH ₃	Acetone
C ₆ H ₇ O ₅ (NO ₂) ₃	Nitrocellulose	CH ₃ COC ₂ H ₅	Methyl Ethyl Ketone (MEK)
(C ₆ H ₁₀ O ₅) _x	Starch	CH ₃ CH ₂ NH ₂	Ethylamine
COOH(CH ₂) ₂ CH(NH ₂)COONa	Sodium Glutamate (MSG)	(CH ₂ OHCH ₂) ₃ N	Triethanolamine
CH ₂ CHCN	Acrylonitrile	CH ₃ CONH ₂	Acetamide
CH ₂ CHCH ₂ OH	Allyl Alcohol	C ₅ H ₅ N	Pyridine
CH ₃ CH ₂ CH ₂ OH	Propyl Alcohol	C ₆ H ₅ NH ₂	Aniline
CH ₃ (CH ₂) ₄ OH	Amyl Alcohol	C ₂ H ₄ (NH ₂) ₂	Ethylenediamine
C ₆ H ₅ CH ₂ OH	Benzyl Alcohol	(CH ₃) ₂ NNH ₂	Dimethyl Hydrazine
CH ₃ (CH ₂) ₃ OH	Butyl Alcohol	CO(NH ₂) ₂	Urea
C ₄ H ₃ OCH ₂ OH	Furfuryl Alcohol	CH ₃ CHO	Acetaldehyde
C _n H _{2n+1} OH	Alcohol General Formula	CH ₂ O	Formaldehyde
C ₆ H ₅ OH	Carbolic Acid (Phenol)	CH ₃ COOC ₅ H ₁₁	Amyl Acetate
C ₃ H ₅ (OH) ₃	Glycerin, Glycerol	CH ₃ COOC ₄ H ₉	Butyl Acetate
CH ₃ OH	Methyl Alcohol	CH ₃ COOC ₂ H ₅	Ethyl Acetate
C ₂ H ₅ OH	Ethyl Alcohol	CH ₃ COONa	Sodium Acetate
CH ₂ OHCH ₂ OH	Ethylene Alcohol (Glycol)	C ₁₇ H ₃₅ COONa	Sodium Stearate
CH ₂ OHCH ₂ OCH ₂ CH ₂ OCH ₂ CH ₂ OH	Triethylene Glycol	(CH ₃ COO) ₂ Zn	Zinc Acetate
CH ₂ ClCOOH	Chloroacetic Acid (mono-)	C ₆ H ₅ SO ₃ Na	Sodium Benzene Sulfonate
CH ₃ (CH ₂) ₂ COOH	Butyric Acid	CS ₂	Carbon Bi or Disulfide
CH ₃ CH ₂ COOH	Propionic Acid	CrCl ₃	Chromic Chloride
CH ₃ (CH ₂) ₁₆ COOH	Stearic Acid	Cr ₂ (SO ₄) ₃	Chromium Sulfate
CH ₃ (CH) ₄ COOH	Sorbic Acid	CuCl ₂	Copper Chloride
CH ₃ CHOHCOOH	Lactic Acid	Cu(CN) ₂	Copper Cyanide
CH ₃ COOH	Acetic Acid	Cu(NO ₃) ₂ • H ₂ O	Copper Nitrate
C ₆ H ₅ COOH	Benzoic Acid	CuS	Copper Sulfide
(CHCOOH) ₂	Maleic Acid	CuSO ₄ • 5H ₂ O	Copper Sulfate
C _n H _{2n+1} COOH	General Formula for Fatty Acids	D ₂ O	Heavy Water, Deuterium Oxide
C ₇₆ H ₅₂ O ₄₆	Tannic Acid	F ₂	Fluorine
C ₆ H ₂ (OH) ₃ COOH • H ₂ O	Gallic Acid	FeCl ₃	Ferric Chloride
CH ₂ SHCOOH	Thioglycolic Acid	Fe ₂ O ₃	Iron Oxide
CO ₂ + H ₂ O	Carbonic Acid	H ₂	Hydrogen
COOH(CH ₂) ₂ CH(NH ₂)COOH	Glutamic Acid	He	Helium
COOH(CH ₂) ₄ COOH	Adipic Acid	H ₃ AsO ₄ • 1/2 H ₂ O	Arsenic Acid

HBF ₄	Fluoboric Acid (Boro & Hydro)
H ₃ BO ₃	Boric Acid
HBrO ₃	Bromic Acid
HCl.....	Hydrochloric Acid
HCl + HNO ₃	Aqua Regia
HCN.....	Hydrocyanic Acid (Prussic)
HCOOH.....	Formic Acid
H ₂ CrO ₄	Chromic Acid
HF.....	Hydrofluoric Acid
HNO ₃	Nitric Acid
H ₂ NNH ₂	Hydrazine
H ₂ O.....	Water
H ₂ O ₂	Hydrogen Peroxide
HOCl.....	Hypochlorous Acid
H ₃ PO ₄	Phosphoric Acid
H ₂ SiF ₆	Fluosilicic Acid (Hydro)
H ₂ SO ₃	Sulfurous Acid
H ₂ SO ₄	Sulfuric Acid
HSO ₃ NH ₂	Sulfamic Acid
KClO ₄	Potassium Perchlorate
K ₂ CrO ₄	Potassium Chromate
K ₂ Cr ₂ O ₇	Potassium Di Chromate
KClO ₃	Potassium Perchlorate
KH ₂ PO ₄	Potassium Phosphate (Mono)
KI.....	Potassium Iodide
KMnO ₄	Potassium Permanganate
KNO ₃	Potassium Nitrate
KOCl.....	Potassium Hypochlorite
KOH.....	Potassium Hydroxide (Potash)
K ₂ SO ₄	Potassium Sulfate
LiBr.....	Lithium Bromide
MgCl ₂ • 6H ₂ O.....	Magnesium Chloride
MgCO ₃	Magnesium Carbonate
MgO.....	Magnesium Oxide
Mg(OH) ₂	Magnesium Hydroxide
MgSO ₄	Magnesium Sulfate
Mg ₃ S ₁₄ O ₁₀ (OH) ₂	Talc Slurry
N ₂	Nitrogen
Na ₂ B ₄ O ₇ • 10H ₂ O.....	Borax, Sodium Borate
NaBO ₂ • H ₂ O ₂ • 10H ₂ O.....	Sodium Perborate
NaCl.....	Sodium Chloride
Na ₂ Cr ₂ O ₇ • 2H ₂ O.....	Sodium Dichromate
Na ₂ CrO ₄ 10H ₂ O.....	Sodium Chromate
NaCN.....	Sodium Cyanide
NaClO ₃	Sodium Chlorate
Na ₂ CO ₃	Sodium Carbonate
NaF.....	Sodium Fluoride
NaHCO ₃	Sodium Bicarbonate
NaH ₂ PO ₄	Sodium Phosphate (Mono)
NaHSO ₃	Sodium Bisulfite
NaNO ₃	Sodium Nitrate
Na ₂ O ₂	Sodium Peroxide
Na(OCl).....	Sodium Hypochlorite
NaOH.....	Sodium Hydroxide (Caustic)
NaS.....	Sodium Sulfide
Na ₂ SO ₃	Sodium Sulfite
Na ₂ SO ₄	Sodium Sulfate
Na ₂ S ₂ O ₈	Sodium Persulfate
Na ₂ S ₂ O ₃ • 5H ₂ O.....	Sodium Thiosulfate (Hypo)
Na ₂ SiF ₆	Sodium Silicofluoride
Na ₂ SiO ₃	Sodium Metasilicate
NH ₃	Ammonia
NH ₄ Cl.....	Ammonium Chloride

(NH ₄) ₂ HPO ₄	Ammonium Phosphate, (DI)
NH ₄ NO ₃	Ammonium Nitrate
NH ₄ OH.....	Ammonium Hydroxide
(NH ₄) ₂ S ₂ O ₈	Ammonium Persulfate
(NH ₄) ₂ SO ₄	Ammonium Sulfate
NiCl ₂	Nickel Chloride
NiSO ₄	Nickel Sulfate
O ₂	Oxygen
O ₃	Ozone
Pb ₃ (AsO ₄) ₂	Lead Arsenate
Pb(C ₂ H ₅) ₄	Lead Tetraethyl
Pb(C ₂ H ₃ O ₂) ₂ • 3H ₂ O.....	Lead Acetate
Pb ₃ O ₄ (Also PbO).....	Lead Oxide Litharge
PCl ₃	Phosphorous Trichloride
POCl ₃	Phosphorous Oxychloride
S.....	Sulfur
SiCl ₄	Silcon Tetrachloride
SiO ₂	Silica
SnCl ₂	Stannic Chloride
SnF ₂	Stannous Fluoride
SO ₂	Sulfur Dioxide
SO ₂ ClOH.....	Chlorosulfonic Acid
TiO ₂	Titanium Dioxide
ZnCl ₂	Zinc Chloride
ZnO.....	Zinc Oxide
ZnS.....	Zinc Sulfide
ZnSO ₄ • 7H ₂ O.....	Zinc Sulfate

The following information is recommended as a minimum for effective use of the Service Guide:

- Fluid Being Handled
- Concentration
- Temperature
- Pressure
- Line Size
- Type of Piping

Rubber Lining Correlation

Lining Material	Rubber #
Hard Rubber	10
Soft Rubber	5
Neoprene	7
Chlorobutyl	16

The correlation between the Diaphragm Material recommended in the Service Guide and ITT diaphragm codes is shown on the section 5 page 80 table. The table above shows the correlation between rubber lining material and the ITT rubber number.

Service Guide

SERVICE	BODY			DIAPHRAGM			REMARKS
	MATERIAL	MAXIMUM		MATERIAL	MAXIMUM		
		CONC BY WT	TEMP °F		CONC BY WT	TEMP °F	
ABRASIVE SLURRY	C. I.	ALL	275	EPDM	ALL	275	Materials depend on nature of abrasive; Generally best to use Straightways for on / off and Dualrange or Weir for throttling
	GLASS	ALL	275	Neoprene Natural Rubber	ALL	180	
	ST. STL.	ALL	275		ALL	180	
	Hard Rubber	ALL	200				
	Soft Rubber	ALL	150				
	Neoprene	ALL	150				
ACETALDEHYDE CH ₃ CHO	ST. STL.	ALL	300	PTFE	ALL	300	
	PFA	ALL	350				
	ETFE	ALL	300				
ACETAL RESIN SLURRY (—CH ₂ —O—) _n	GLASS	ALL	350*	PTFE	ALL	350	*Use Glass lined DI above 325° F
	ST. STL.	ALL	350	EPDM	ALL	275	
	PFA	ALL	350				
	ETFE	ALL	300				
ACETAMIDE CH ₃ CON H ₂	GLASS	ALL	350*	PTFE	ALL	350	Check if solvent present. EPDM has limited solvent application *Use Glass lined DI above 325° F
	PFA	ALL	350	EPDM	ALL	275	
	ETFE	ALL	300	Viton	ALL	212	
	POLYPROP	80	125				
	PVC	80	200				
ACETIC ACID CH ₃ COOH B.P. 245°F	GLASS	ALL	245	PTFE	ALL	245	
	PFA	ALL	245				
	ETFE	ALL	245				
	POLYPROP	80	125				
	PVDF	50	150				
	PVC	80	125				
ACETIC ANHYDRIDE (CH ₃ CO) ₂ O B.P. 284°F	GLASS	ALL	284	PTFE	ALL	284	
	ST. STL.	ALL	284				
	HASTELLOY-C	ALL	284				
	PFA	ALL	284				
	ETFE	ALL	133				
ACETONE CH ₃ COCH ₃ B.P. 133°F	GLASS	ALL	133	PTFE	ALL	133	
	ST. STL.	ALL	133	EPDM	ALL	133	
	C. I.	ALL	133	Butyl	ALL	133	
	PFA	ALL	133				
	ETFE	ALL	133				
	POLYPROP	ALL	75				
ACETYLENE C ₂ H ₂	D. I.	ALL	350	PTFE	ALL	350	Avoid copper alloys
	C. ST.	ALL	350	Neoprene	ALL	150	
	ST. STL.	ALL	350				
	C. I.	ALL	350				
	PVDF	ALL	250				
ACRYLONITRILE CH ₂ CH CN	GLASS	ALL	350*	PTFE	ALL	350	*Use Glass lined DI above 325° F Hazardous
	ST. STL.	ALL	350				
	PFA	ALL	200				
	ETFE	ALL	150				
	PVDF	ALL	100				
ADIPIIC ACID COOH (CH ₂) ₄ COOH	GLASS	ALL	300	PTFE	ALL	300	Melting point 305° F, check solvent
	ST. STL.	ALL	300				
	PFA	ALL	250				
	ETFE	ALL	250				
	PVDF	ALL	200				
	CPVC	ALL	190				
	PVC	ALL	140				

Service Guide

SERVICE	BODY			DIAPHRAGM			REMARKS
	MATERIAL	MAXIMUM		MATERIAL	MAXIMUM		
		CONC BY WT	TEMP °F		CONC BY WT	TEMP °F	
AIR (dry)	ANY METAL CPVC PVC PVDF	ALL ALL ALL ALL	350 190 140 285	PTFE EPDM Butyl Neoprene	ALL ALL ALL ALL	350 275 250 200	Butyl is least permeable of elastomer diaphragms; Do not use EPDM if oil is present
AIR (moist)	BRONZE ST. STL. CPVC PVC PVDF	ALL ALL ALL ALL ALL	350 350 190 140 285	PTFE EPDM Butyl Neoprene	ALL ALL ALL ALL	350 300 250 200	Do not use EPDM if oil is present
AIR (oily)	ANY METAL POLYPROP CPVC PVDF	ALL ALL ALL ALL	350 200 190 285	PTFE Nitrile Neoprene	ALL ALL ALL	350 180 150	
ALBUMEN	GLASS BRONZE PFA ETFE POLYPROP PVC	ALL ALL ALL ALL ALL ALL	350* 350 350 300 200 140	PTFE Butyl White Butyl	ALL ALL ALL	350 225 225	*Use Glass lined DI above 325° F
ALCOHOL, ALLYL CH ₂ CH CH ₂ OH B.P. 207°F	C. I. ST. STL. GLASS PFA ETFE POLYPROP PVDF	ALL ALL ALL ALL ALL ALL ALL	207 207 207 207 207 200 120	PTFE EPDM Butyl Neoprene	ALL ALL ALL ALL	207 207 175 160	Cl will rust if moisture present
ALCOHOL, AMYL CH ₃ (CH ₂) ₄ OH B.P. 280°F	C. I. ST. STL. GLASS PFA ETFE PVDF POLYPROP	ALL ALL ALL ALL ALL ALL ALL	280 280 280 280 280 275 200	PTFE EPDM Butyl Neoprene	ALL ALL ALL ALL	280 200 175 160	
ALCOHOL, BENZYL C ₆ H ₅ CH ₂ OH B.P. 402°F	ST. STL. GLASS PFA ETFE PVDF	ALL ALL ALL ALL ALL	350 350* 350 300 250	PTFE Viton	ALL ALL	350 250	*Use Glass lined DI above 325° F
ALCOHOL, BUTYL CH ₃ (CH ₂) ₃ OH B.P. 242°F	ANY METAL PFA ETFE PVDF GLASS POLYPROP	ALL ALL ALL ALL ALL ALL	242 242 242 242 242 200	PTFE EPDM Neoprene Butyl	ALL ALL ALL ALL	242 242 200 225	Cl will rust if moisture present
ALCOHOL, ETHYL (Denatured Alcohol) C ₂ H ₅ OH B.P. 172°F	C. I. BRONZE PFA ETFE PVDF POLYPROP ST. STL.	ALL ALL ALL ALL ALL ALL ALL	172 172 172 172 172 172 172	PTFE EPDM Butyl	ALL ALL ALL	172 172 172	Cl will rust if moisture present
ALCOHOL, ETHYLENE CH ₂ OHCH ₂ OH							See "GLYCOL"

Service Guide

SERVICE	BODY			DIAPHRAGM			REMARKS
	MATERIAL	MAXIMUM		MATERIAL	MAXIMUM		
		CONC BY WT	TEMP °F		CONC BY WT	TEMP °F	
ALCOHOL, FURFURYL C ₄ H ₃ OCH ₂ OH B.P. 338°F	ANY METAL GLASS PFA ETFE	ALL ALL ALL ALL	338 338* 338 212	PTFE	ALL	338	*Use Glass lined DI above 325° F
ALCOHOL, METHYL CH ₃ OH B.P. 148°F	ANY METAL GLASS PFA ETFE PVDF POLYPROP CPVC PVC	ALL ALL ALL ALL ALL ALL ALL ALL	148 148 148 148 148 148 148 140	PTFE EPDM Butyl Nitrile	ALL ALL ALL ALL	148 148 148 148	Cl will rust if moisture present
ALCOHOL, PROPYL CH ₃ CH ₂ CH ₂ OH B.P. 207°F	ANY METAL GLASS PFA ETFE PVDF POLYPROP Hard Rubber CPVC PVC	ALL ALL ALL ALL ALL ALL ALL ALL ALL	207 207 207 207 207 200 150 150 140	PTFE EPDM Butyl Nitrile	ALL ALL ALL ALL	207 207 200 150	Cl will rust if moisture present
ALKALI							See specific hydroxide
ALUM, AMMONIUM AlNH ₄ (SO ₄) ₂ • 12 H ₂ O	PFA ETFE ST. STL. PVDF POLYPROP Hard Rubber PVC	ALL ALL ALL ALL ALL ALL ALL	250 250 250 250 200 200 140	EPDM Butyl Neoprene	ALL ALL ALL	250 225 200	
ALUM, POTASSIUM AlK (SO ₄) ₂ • 12 H ₂ O	ST. STL. PFA ETFE PVDF POLYPROP Hard Rubber CPVC PVC	ALL ALL ALL ALL ALL ALL ALL ALL	350 350 300 275 200 200 190 140	PTFE EPDM Butyl Neoprene	ALL ALL ALL ALL	350 275 225 180	
ALUMINA TRIHYDRATE Al ₂ O ₃ • 3H ₂ O	C. I. Soft Rubber	ALL ALL	225 150	EPDM Neoprene Natural Rubber	ALL ALL ALL	200 180 180	Use of Cl depends on velocity, as service is abrasive
ALUMINUM CHLORIDE AlCl ₃	GLASS PFA ETFE PVDF POLYPROP Hard Rubber CPVC PVC	ALL ALL ALL ALL ALL ALL ALL ALL	350* 350 300 275 200 200 190 140	PTFE EPDM Butyl Neoprene	ALL ALL ALL ALL	350 275 200 200	*Use Glass lined DI above 325° F

Service Guide

SERVICE	BODY			DIAPHRAGM			REMARKS
	MATERIAL	MAXIMUM		MATERIAL	MAXIMUM		
		CONC BY WT	TEMP °F		CONC BY WT	TEMP °F	
ALUMINUM SULFATE $Al_2(SO_4)_3 \cdot 18H_2O$	PFA	ALL	350	PTFE	ALL	300	
	ETFE	ALL	300	EPDM	ALL	275	
	PVDF	ALL	275	Butyl	ALL	225	
	POLYPROP	ALL	200	Neoprene	ALL	180	
	Hard Rubber	ALL	200				
	CPVC	ALL	190				
	PVC	ALL	140				
AMINO ACIDS	GLASS	ALL	350*	PTFE	ALL	350	*Use Glass lined DI above 325° F
	ST. STL.	ALL	350	EPDM	ALL	250	
	PFA	ALL	280	Butyl	ALL	225	
	ETFE	ALL	280				
AMMONIUM HYDROXIDE NH_4OH (AQUEOUS AMMONIA)	C. I.	ALL	350	PTFE	ALL	350	No copper; sealed bonnet recommended
	ST. STL.	ALL	350	EPDM	ALL	275	
	D. I.	ALL	350	Butyl	ALL	225	
	PFA	ALL	350	Neoprene	ALL	180	
	ETFE	ALL	300				
	PVDF	ALL	225				
	POLYPROP PVC	ALL ALL	200 140				
AMMONIUM CHLORIDE $NH_4 Cl$	GLASS	ALL	350*	PTFE	ALL	350	*Use Glass lined DI above 325° F
	PFA	ALL	350	EPDM	ALL	250	
	ETFE	ALL	300	Butyl	ALL	250	
	PVDF	ALL	275				
	CPVC	ALL	190				
	Hard Rubber	ALL	180				
	POLYPROP	ALL	150				
	PVC	ALL	140				
AMMONIUM NITRATE $NH_4 NO_3$	C. I.	ALL	350	PTFE	ALL	350	*Use Glass lined DI above 325° F
	C. STL.	ALL	350	EPDM	ALL	275	
	POLYPROP	ALL	200	Butyl	ALL	225	
	CPVC	ALL	190	Neoprene	ALL	200	
	Hard Rubber	70	180				
	PVC	ALL	140	Nitrile	ALL	180	
	PVDF	ALL	275				
AMMONIUM PERSULFATE $(NH_4)_2 S_2 O_8$	GLASS	ALL	350*	PTFE	ALL	350	*Use Glass lined DI above 325° F
	PFA	ALL	275	EPDM	ALL	250	
	ETFE	ALL	275	Butyl	ALL	225	
	Hard Rubber	ALL	200	Nitrile	ALL	180	
	POLYPROP	ALL	150				
	PVC	ALL	140				
(DI) AMMONIUM PHOSPHATE $(NH_4)_2 HPO_4$	GLASS	ALL	350*	PTFE	ALL	350	*Use Glass lined DI above 325° F; Steam out lines use grade EPDM
	ST. STL. (316)	ALL	350	EPDM	ALL	275	
	PFA	ALL	350	Butyl	ALL	250	
	ETFE	ALL	300	Neoprene	ALL	200	
	PVDF	ALL	275				
	POLYPROP	ALL	200				
	PVC	ALL	140				
AMMONIUM SULFATE $(NH_4)_2 SO_4$	PFA	ALL	350	PTFE	ALL	300	
	ETFE	ALL	300	EPDM	ALL	275	
	PVDF	ALL	275	Butyl	ALL	250	
	POLYPROP	ALL	200	Neoprene	ALL	200	
	Hard Rubber	ALL	180				
	Neoprene	ALL	180				
	PVC	ALL	140				

Service Guide

SERVICE	BODY			DIAPHRAGM			REMARKS
	MATERIAL	MAXIMUM		MATERIAL	MAXIMUM		
		CONC BY WT	TEMP °F		CONC BY WT	TEMP °F	
AMYL ACETATE CH ₃ COOC ₅ H ₁₁	C. I.	ALL	350	PTFE	ALL	350	PVDF and Polyprop may be used to 125° F; Avoid elastomer diaphragms *Use Glass lined DI above 325° F.
	BRONZE	ALL	350				
	GLASS	ALL	350*				
	PFA	ALL	250				
	ETFE	ALL	250				
	PVDF	ALL	125				
ANILINE C ₆ H ₅ NH ₂	C. I.	ALL	350	PTFE Butyl	ALL ALL	350 150	*Use Glass lined DI above 325° F
	BRONZE	ALL	350				
	GLASS	ALL	350*				
	PFA	ALL	350				
	ETFE	ALL	230				
ANTIBIOTICS	GLASS	ALL	350*	PTFE Butyl White Butyl	ALL ALL	350 250	Check carrier *Use Glass lined DI above 325° F
	ST. STL.	ALL	350				
ANTIMONY SALTS	GLASS	ALL	350*	PTFE EPDM Butyl	ALL ALL ALL	350 275 250	Check solvent *Use Glass lined DI above 325° F
	PFA	ALL	350				
	ETFE	ALL	300				
	POLYPROP	ALL	150				
	Hard Rubber	ALL	150				
	PVC	ALL	140				
	PVDF	ALL	275				
AQUA REGIA HCl + HNO ₃	GLASS	ALL	350*	PTFE Viton	ALL ALL	350 180	*Use Glass lined DI above 325° F
	PFA	ALL	248				
	ETFE	ALL	212				
ARSENIC ACID H ₃ AsO ₄ • ½ H ₂ O	ST. STL.	ALL	350	PTFE EPDM Butyl Nitrile	ALL ALL ALL ALL	350 250 225 180	
	PFA	ALL	350				
	ETFE	ALL	300				
	PVDF	ALL	275				
	Hard Rubber	ALL	200				
	POLYPROP	ALL	200				
	PVC	ALL	140				
ASPHALT	C. I.	ALL	350	PTFE	ALL	350	If in solution, solvent may allow use of Nitrile; Check first
	PFA	ALL	350				
	ETFE	ALL	300				
	PVDF	ALL	250				
BAGASSE	C. I.	ALL	350	EPDM Natural Rubber	ALL ALL	300 180	Check carrier
	Soft Rubber	ALL	150				
BARIUM SALTS	GLASS	ALL	350*	PTFE EPDM Neoprene	ALL ALL ALL	350 300 200	Cl sometimes used; Check carrier *Use Glass lined DI above 325° F
	ST. STL.	ALL	350				
	PFA	ALL	350				
	ETFE	ALL	300				
	PVDF	ALL	275				
	Hard Rubber	ALL	200				
	POLYPROP	ALL	200				
	PVC	ALL	140				
BARIUM SULFATE Ba SO ₄	GLASS	ALL	275	EPDM Neoprene Natural Rubber	ALL ALL ALL	275 200 180	Check carrier; Can be very abrasive; PVC not good choice when abrasive
	PFA	ALL	275				
	ETFE	ALL	275				
	Soft Rubber	ALL	150				
	PVC	ALL	140				
	PVDF	ALL	275				

Service Guide

SERVICE	BODY			DIAPHRAGM			REMARKS
	MATERIAL	MAXIMUM		MATERIAL	MAXIMUM		
		CONC BY WT	TEMP °F		CONC BY WT	TEMP °F	
BATTERY ACID (See Sulfuric Acid)	GLASS	37	350*	PTFE	37	350	Maximum 37% sulfuric acid *Use Glass lined DI above 325° F
	PFA	ALL	350	EPDM	37	150	
	ETFE	37	300	Butyl	37	150	
	PVDF	37	250				
	Hard Rubber	37	150				
	POLYPROP	37	150				
	PVC	37	140				
BEER	ST. STL.	ALL	350	PTFE	ALL	350	*Use Glass lined DI above 325° F
	BRONZE	ALL	350	Butyl	ALL	250	
	GLASS	ALL	350*	White Butyl	ALL	225	
	PVDF	ALL	225				
BENZENE C ₆ H ₆ B.P. 176°F	C.I.	ALL	176	PTFE	ALL	176	
	BRONZE	ALL	176				
	GLASS	ALL	176				
	PFA	ALL	176				
	ETFE	ALL	176				
	PVDF	ALL	170				
BENZOIC ACID C ₆ H ₅ COOH	ST. STL.	ALL	350	PTFE	ALL	350	*Use Glass lined DI above 325° F
	GLASS	ALL	350*	Butyl	ALL	250	
	PFA	ALL	350				
	ETFE	ALL	300				
	PVDF	ALL	225				
	PVC	ALL	150				
BILGE LINES	C. I.	ALL	350	PTFE	ALL	350	*If oils are present, use Neoprene or Nitrile with travel stops.
	BRONZE	ALL	350	EPDM*	ALL	275	
	PFA	ALL	350	Neoprene Nitrile	ALL	200	
	ETFE	ALL	300				
	PVDF	ALL	275				
	POLYPROP	ALL	200				
	PVC	ALL	140				
BLACK LIQUOR (SULFATE)	C. I.	ALL	300	PTFE	ALL	300	
	PFA	ALL	350	Neoprene Nitrile	ALL	200	
	ETFE	ALL	300				
	PVDF	ALL	175				
	Hard Rubber	ALL	200				
	CPVC	ALL	190				
BLEACH							
BLOOD, ANIMAL	ST. STL.	ALL	350	PTFE	ALL	350	*If fats are present, use Nitrile with travel stops
	BRONZE	ALL	350	White Butyl*	ALL	225	
	C. I.	ALL	350	EPDM*	ALL	225	
	PFA	ALL	350	Nitrile	ALL	180	
	ETFE	ALL	300				
	PVC	ALL	140				
	PVDF	ALL	275				
BLOOD, HUMAN	ST. STL.	ALL	350	PTFE	ALL	350	*Use Glass lined DI above 325° F **If fats are present, use Nitrile with travel stops
	GLASS	ALL	350*	White Butyl**	ALL	225	
	PVDF	ALL	275	EPDM**	ALL	225	
BONDERITE	PFA	ALL	350	PTFE	ALL	300	Cl also used
	ETFE	ALL	300	EPDM	ALL	275	
	Hard Rubber	ALL	200	Butyl	ALL	250	
	ST. STL.	ALL	180				
	PVC	ALL	140	Neoprene	ALL	200	

Service Guide

SERVICE	BODY			DIAPHRAGM			REMARKS
	MATERIAL	MAXIMUM		MATERIAL	MAXIMUM		
		CONC BY WT	TEMP °F		CONC BY WT	TEMP °F	
BORAX Na ₂ B ₄ O ₇ • 10 H ₂ O	C. I.	ALL	350	PTFE	ALL	350	
	PFA	ALL	350	EPDM	ALL	275	
	ETFE	ALL	300	Butyl Neoprene Natural Rubber	ALL	225	
	PVDF	ALL	275		ALL	200	
	Hard Rubber	ALL	150		ALL	180	
	Soft Rubber	ALL	150				
	PVC	ALL	140				
BORIC ACID H ₃ BO ₃	BRONZE	ALL	350	PTFE	ALL	350	
	ST. STL.	ALL	350	EPDM	ALL	275	
	PFA	ALL	350	Butyl	ALL	250	
	ETFE	ALL	300	Neoprene	ALL	200	
	PVDF	ALL	275				
	POLYPROP	ALL	200				
	Hard Rubber	ALL	175				
	PVC	ALL	140				
BRINE (SODIUM CHLORIDE) NaCl	PFA	ALL	350	PTFE	ALL	300	Recommendation based on no free chlorine
	ETFE	ALL	300	EPDM	ALL	275	
	PVDF	ALL	285	Butyl	ALL	250	
	Hard Rubber	ALL	200	Neoprene	ALL	180	
	POLYPROP	ALL	200				
	PVC	ALL	140				
BROMIC ACID HBr O ₃	GLASS	50	350*	PTFE	ALL	350	*Use Glass lined DI above 325° F
	PVDF	ALL	275	Butyl	50	100	
	PFA	ALL	250				
	ETFE	ALL	250				
	CPVC	50	190				
	PVC	50	140				
BROMINE WATER Br + H ₂ O	GLASS	ALL	350*	PTFE	ALL	350	*Use Glass lined DI above 325° F
	PFA	ALL	230				
	ETFE	ALL	230				
	PVDF	ALL	210				
	PVC	ALL	140				
BUTADIENE C ₄ H ₆	D. I.	ALL	350	PTFE	ALL	350	
	ST. STL.	ALL	350				
	PFA	ALL	250				
	ETFE	ALL	250				
	PVDF	ALL	250				
BUTANE C ₄ H ₁₀	ANY METAL	ALL	350	PTFE	ALL	350	Avoid Cl if danger of explosion
	PFA	ALL	250	Nitrile	ALL	180	
	ETFE	ALL	300				
	PVDF	ALL	285				
BUTYL ACETATE CH ₃ COOC ₄ H ₉	ANY METAL	ALL	350	PTFE	ALL	350	*Use Glass lined DI above 325° F
	GLASS	ALL	350*				
	PFA	ALL	260				
	ETFE	ALL	230				
	POLYPROP	ALL	75				
BUTYRIC ACID CH ₃ (CH ₂) ₂ COOH	ST. STL.	ALL	350	PTFE	ALL	350	*Use Glass lined DI above 325° F
	GLASS	ALL	350*	EPDM	ALL	100	
	PFA	ALL	250				
	ETFE	ALL	250				
	PVDF	ALL	230				
	POLYPROP	ALL	150				

Service Guide

SERVICE	BODY			DIAPHRAGM			REMARKS
	MATERIAL	MAXIMUM		MATERIAL	MAXIMUM		
		CONC BY WT	TEMP °F		CONC BY WT	TEMP °F	
CALCIUM BISULFITE Ca (HSO ₃) ₂	GLASS	ALL	350*	PTFE	ALL	350	*Use Glass lined DI above 325° F
	ST. STL.	ALL	350	EPDM	ALL	275	
	PFA	ALL	350	Butyl	ALL	225	
	ETFE	ALL	300				
	PVDF	ALL	275				
	POLYPROP	ALL	200				
	CPVC	ALL	190				
	Neoprene PVC	ALL ALL	150 140				
CALCIUM CARBONATE Ca CO ₃	C. I.	ALL	350	PTFE	ALL	350	Cl will rust if moisture present
	PFA	ALL	350	EPDM	ALL	275	
	ETFE	ALL	300	Butyl	ALL	250	
	PVDF	ALL	285				
	POLYPROP	ALL	200	Neoprene	ALL	200	
	CPVC	ALL	190	Natural Rubber	ALL	180	
	Neoprene	ALL	180				
	Soft Rubber PVC	ALL ALL	150 140				
CALCIUM CHLORIDE Ca Cl ₂	GLASS	ALL	350*	PTFE	ALL	350	Cl possible; *Use Glass lined DI above 325° F
	PFA	ALL	350	EPDM	ALL	250	
	ETFE	ALL	300	Butyl	ALL	225	
	PVDF	ALL	285				
	Hard Rubber	ALL	200	Neoprene	ALL	200	
	POLYPROP	ALL	150				
	PVC	ALL	140				
CALCIUM HYDROXIDE Ca (OH) ₂	ANY METAL	ALL	350	PTFE	ALL	350	
	PFA	ALL	350	EPDM	ALL	250	
	ETFE	ALL	300	Butyl	ALL	212	
	PVDF	ALL	275				
	POLYPROP	ALL	200	Neoprene	ALL	200	
	CPVC	ALL	190	Natural Rubber	ALL	180	
	Soft Rubber	ALL	150				
	PVC	ALL	140				
CALCIUM HYPOCHLORITE Ca (OCI) ₂	GLASS	ALL	350*	PTFE	ALL	350	*Use Glass lined DI above 325° F
	PFA	ALL	350				
	ETFE	ALL	300	EPDM	20	125	
	PVDF	ALL	200				
	Hard Rubber	ALL	150				
	PVC	ALL	140				
	POLYPROP	ALL	120				
CALCIUM OXIDE Ca O							See "Calcium Hydroxide"
CALCIUM SULFATE Ca SO ₄	C. I.	ALL	350	EPDM	ALL	275	Check carrier; may be abrasive
	PFA	ALL	350				
	ETFE	ALL	300	Neoprene	ALL	200	
	PVDF	ALL	285	Natural Rubber	ALL	180	
	POLYPROP	ALL	200				
	Soft Rubber	ALL	150				
CARBOLIC ACID OR PHENOL C ₆ H ₅ OH	GLASS	ALL	350*	PTFE	ALL	350	*Use Glass lined DI above 325° F
	ST. STL.	ALL	350	Viton	ALL	200	
	BRONZE	ALL	350				
	PFA	ALL	230	EPDM	ALL	75	
	ETFE	ALL	230				
	PVDF	ALL	210				

Service Guide

SERVICE	BODY			DIAPHRAGM			REMARKS
	MATERIAL	MAXIMUM		MATERIAL	MAXIMUM		
		CONC BY WT	TEMP °F		CONC BY WT	TEMP °F	
CARBONATED BEVERAGES	ST. STL. BRONZE POLYPROP PVDF	ALL ALL ALL ALL	250 250 200 250	Butyl White Butyl EPDM (FDA)	ALL ALL ALL	250 225 250	
CARBON BLACK SLURRY	GLASS C. I. C. STL Soft Rubber	ALL ALL ALL ALL	350* 350 350 150	EPDM Butyl Neoprene Natural Rubber	ALL ALL ALL ALL	300 250 180 180	Check carrier *Use Glass lined DI above 325° F
CARBON BISULFIDE CS ₂	GLASS ANY METAL PFA ETFE	ALL ALL ALL ALL	350* 350 150 150	PTFE Viton	ALL ALL	350* 175	*Use Glass lined DI above 325° F
CARBON DIOXIDE CO ₂	ANY METAL PFA ETFE PVDF CPVC POLYPROP PVC	ALL ALL ALL ALL ALL ALL ALL	350 350 300 285 190 150 140	PTFE EPDM Butyl Neoprene	ALL ALL ALL ALL	350 300 250 200	
CARBONIC ACID CO ₂ + H ₂ O	BRONZE ST. STL. POLYPROP Hard Rubber Soft Rubber PVC PVDF	ALL ALL ALL ALL ALL ALL ALL	350 350 200 200 150 140 275	PTFE EPDM Butyl Neoprene	ALL ALL ALL ALL	350 250 250 200	
CARBON TETRACHLORIDE CCl ₄	GLASS MONEL PFA ETFE PVDF	ALL ALL ALL ALL ALL	350* 350 250 250 250	PTFE Viton	ALL ALL	350 150	*Use Glass lined DI above 325° F
CASEIN	C. I. BRONZE ST. STL. PFA ETFE Hard Rubber, Neoprene PVDF	ALL ALL ALL ALL ALL ALL ALL	350 350 350 350 300 200 250	PTFE EPDM Butyl Neoprene	ALL ALL ALL ALL	350 275 250 200	Check carrier
CAUSTIC SODA CEMENT SLURRY	C. I. Soft Rubber	ALL ALL	250 150	EPDM Natural Rubber	ALL ALL	250 180	See "Sodium Hydroxide"
CERAMIC SLURRY	C. I. Soft Rubber	ALL ALL	250 150	EPDM Natural Rubber	ALL ALL	250 180	Cl use depends on velocity, as service is abrasive
CEREAL	ST. STL. BRONZE GLASS PFA ETFE PVDF	ALL ALL ALL ALL ALL ALL	350 350 350* 350 300 285	PTFE Butyl White Butyl	ALL ALL ALL	350 250 225	*Use Glass lined DI above 325° F

Service Guide

SERVICE	BODY			DIAPHRAGM			REMARKS
	MATERIAL	MAXIMUM		MATERIAL	MAXIMUM		
		CONC BY WT	TEMP °F		CONC BY WT	TEMP °F	
CHEMICAL PULP (SODA PROCESS)	C. I.	ALL	350	PTFE	ALL	350	*Use Glass lined DI above 325° F
	ST. STL.	ALL	350		EPDM	ALL	
	GLASS	ALL	350*	Neoprene	ALL	200	
	PFA	ALL	350				
	ETFE	ALL	300				
	Hard Rubber	ALL	200				
CHEMICAL PULP (SULFATE PROCESS)	GLASS	ALL	350*	PTFE	ALL	350	*Use Glass lined DI above 325° F
	PFA	ALL	350	EPDM	ALL	250	
	ETFE	ALL	300	Butyl	ALL	225	
	Hard Rubber	ALL	200	Neoprene	ALL	200	
CHEMICAL PULP (SULFITE PROCESS)	ST. STL.	ALL	350	PTFE	ALL	350	*Use Glass lined DI above 325° F
	GLASS	ALL	350*				
	PFA	ALL	350	Butyl	ALL	250	
	ETFE	ALL	300				
	Hard Rubber	ALL	200				
	PVC	ALL	140				
CHLORINATED BRINE	GLASS	ALL	350*	PTFE	ALL	350	PFA, ETFE or PVDF best choice when abrasion present *Use Glass lined DI above 325° F
	PFA	ALL	350				
	ETFE	ALL	300				
	PVDF	ALL	200				
	Hard Rubber	ALL	200				
	PVC	ALL	140				
CHLORINATED HYDROCARBONS	GLASS	ALL	300	PTFE	ALL	350	May be some HCL released at high temp
	PFA	ALL	250				
	ETFE	ALL	250				
	PVDF	ALL	250				
CHLORINE DIOXIDE SOLUTION Cl O ₂ + H ₂ O	GLASS	ALL	350*	PTFE	ALL	350	*Use Glass lined DI above 325° F
	PFA	ALL	250				
	ETFE	ALL	250				
	PVDF	ALL	210				
	PVC	ALL	140				
CHLORINE (DRY) Cl ₂ LIQUID OR GAS	Recommended Valve – ITT Cam-Tite® Consult your local ITT Engineered Valves Sales Engineer						Use Chlorine Institute approved valves; See page 164
CHLORINE Cl ₂ + H ₂ O GAS (WET)	GLASS	ALL	225	PTFE	ALL	225	Recommended sealed bonnets; See page 166
	PFA	ALL	248				
	ETFE	ALL	225				
	PVDF	ALL	212				
	#12	ALL	180				
CHLORINE WATER Cl ₂ + H ₂ O	GLASS	ALL	350*	PTFE	ALL	350	* Use Glass lined DI above 325° F **Use elastomer diaphragm for infrequent flexing only; See page 166
	PFA	ALL	250				
	ETFE	ALL	250	Natural Rubber**		150	
	PVDF	ALL	225				
	Hard Rubber	ALL	200				
	CPVC	ALL	190	EPDM		150	
	POLYPROP	ALL	150				
	PVC	ALL	140				
CHLOROFORM CHCl ₃	GLASS	ALL	350*	PTFE	ALL	350	Cl suitable if no free chlorine *Use Glass lined DI above 325° F
	PFA	ALL	230				
	ETFE	ALL	230				
	PVDF	ALL	200				
	ST. STL.	ALL	80				

Service Guide

SERVICE	BODY			DIAPHRAGM			REMARKS
	MATERIAL	MAXIMUM		MATERIAL	MAXIMUM		
		CONC BY WT	TEMP °F		CONC BY WT	TEMP °F	
CHLOROSULFONIC ACID $\text{Cl SO}_2 \text{ OH}$	GLASS PFA ETFE	ALL ALL ALL	350* 304 75	PTFE	ALL	350	*Use Glass lined DI above 325° F.
CHOCOLATE PASTE	ST. STL. GLASS PFA ETFE PVDF PVC	ALL ALL ALL ALL ALL ALL	350 350* 350 300 285 140	PTFE Butyl White Butyl	ALL ALL ALL	350 250 225	*Use Glass lined DI above 325° F
CHROMIC ACID $\text{H}_2 \text{ Cr O}_4$	GLASS ST. STL. PFA ETFE CPVC PVDF PVC	ALL ALL ALL 50 50 50 30	350* 350 200 200 190 125 80	PTFE Butyl 	ALL 10	350 110	Glass lined and PTFE diaphragm Preferred *Use Glass lined DI above 325° F
CHROMIC CHLORIDE Cr Cl_3	GLASS PFA ETFE PVDF	ALL ALL ALL ALL	350* 230 230 120	PTFE EPDM 	ALL ALL	350 200	*Use Glass lined DI above 325° F
CHROMIUM SULFATE $\text{Cr}_2 (\text{SO}_4)_3$	GLASS PFA ETFE PVDF ST. STL.	ALL ALL ALL ALL 30	350* 350 300 200 212	PTFE EPDM Butyl 	ALL ALL ALL	350 250 225	*Use Glass lined DI above 325° F
CITRIC ACID & JUICES $\text{C}_6 \text{ H}_8 \text{ O}_7 \cdot \text{H}_2 \text{ O}$	ST. STL. GLASS PFA ETFE PVDF POLYPROP	ALL ALL ALL ALL ALL ALL	350 350* 350 300 275 200	PTFE Neoprene Butyl White Butyl	ALL ALL ALL ALL	350 200 212 200	*Use Glass lined DI above 325° F
CLAY SLIP							See ceramic slurry.
COAL SLURRY (OR AIR BORNE)	C. I. Soft Rubber	ALL ALL	250 150	Natural Rubber	ALL	180	Use of CI depends on velocity, as service is abrasive
COAL TAR	ANY METAL GLASS	ALL ALL	350 350*	PTFE	ALL	350	*Use Glass lined DI above 325° F
COCONUT OIL							See "Oil, Coconut"
COPPER CHLORIDE Cu Cl_2	GLASS PFA ETFE PVDF CPVC PVC POLYPROP	ALL ALL ALL ALL ALL ALL ALL	350* 350 300 285 190 140 120	PTFE EPDM Butyl Neoprene	ALL ALL ALL ALL	350 225 200 150	Copper attacks natural rubber *Use Glass lined DI above 325° F
COPPER CYANIDE Cu (CN)_2	ST. STL. GLASS PFA ETFE PVDF POLYPROP PVC	ALL ALL ALL ALL ALL 10 10	350 350* 350 300 275 200 140	PTFE EPDM Butyl Nitrile	ALL ALL ALL ALL	350 275 250 175	Copper attacks natural rubber, Check solvent *Use Glass lined DI above 325° F

Service Guide

SERVICE	BODY			DIAPHRAGM			REMARKS
	MATERIAL	MAXIMUM		MATERIAL	MAXIMUM		
		CONC BY WT	TEMP °F		CONC BY WT	TEMP °F	
COPPER NITRATE Cu (NO ₃) ₂ • 3 H ₂ O	ST. STL.	ALL	350	PTFE	ALL	350	Copper attacks natural rubber *Use Glass lined DI above 325° F
	GLASS	ALL	350*	EPDM	ALL	275	
	PFA	ALL	350	Butyl	ALL	250	
	ETFE	ALL	300	Nitrile	ALL	180	
	PVDF	ALL	275				
	PVC POLYPROP	ALL ALL	140 120				
COPPER SULFATE CU SO ₄ • 5 H ₂ O (BLUE VITRIOL)	GLASS	ALL	350*	PTFE	ALL	350	Copper attacks natural rubber *Use Glass lined DI above 325° F
	PFA	ALL	350	EPDM	ALL	275	
	ETFE	ALL	300	Butyl	ALL	250	
	PVDF	ALL	285	Nitrile	ALL	180	
	ST. STL.	ALL	200				
	CPVC	ALL	190				
	POLYPROP	ALL	150				
	PVC	ALL	140				
COPPER SULFIDE Cu S	ANY METAL	ALL	350	PTFE	ALL	350	Check solvent first
	PFA	ALL	250	EPDM	ALL	200	
	ETFE	ALL	250	Butyl	ALL	200	
CREOSOTE	ANY METAL	ALL	350	PTFE Viton	ALL ALL	350 210	
CRUDE OIL							See "Oil, Crude"
CYANIDE SOLUTIONS	C. I.	ALL	350	PTFE	ALL	350	
	ST. STL.	ALL	350	EPDM	ALL	250	
	PFA	ALL	250	Butyl	ALL	225	
	ETFE	ALL	250	Neoprene	ALL	200	
	POLYPROP	ALL	150				
	PVC	ALL	140				
DDT (Cl C ₆ H ₄) ₂ CHCCl ₃	GLASS	ALL	350*	PTFE	ALL	350	Acidic; check solvent *Use Glass lined DI above 325° F
	PFA	ALL	350				
	ETFE	ALL	300				
	POLYPROP	ALL	75				
DENATURED ALCOHOL (ETHYL ALCOHOL) C ₂ H ₅ OH							See "Alcohol, Ethyl"
DETERGENTS	C. I.	ALL	350	PTFE	ALL	350	Avoid neoprene
	BRONZE	ALL	350				
	ST. STL.	ALL	350	EPDM	Dilute	250	
	PFA	ALL	350				
	ETFE	ALL	300	Nitrile	ALL	180	
	CPVC	ALL	190				
	POLYPROP	ALL	150				
	PVC	ALL	140				
DEVELOPING SOLUTIONS	ST. STL.	ALL	350	PTFE	ALL	350	Sulphur bearing compounds not allowed *Use Glass lined DI above 325° F
	GLASS	ALL	350*				
	PFA	ALL	350				
	ETFE	ALL	300				
	CPVC	ALL	190				
	POLYPROP	ALL	150				
	PVC	ALL	140				

Service Guide

SERVICE	BODY			DIAPHRAGM			REMARKS
	MATERIAL	MAXIMUM		MATERIAL	MAXIMUM		
		CONC BY WT	TEMP °F		CONC BY WT	TEMP °F	
DIATOMACEOUS EARTH	GLASS	ALL	350*	PTFE	ALL	350	Use of CI depends on velocity, as service is abrasive *Use Glass lined DI above 325° F
	C. I.	ALL	350	EPDM	ALL	250	
	Soft Rubber	ALL	150	Natural Rubber	ALL	180	
DIBUTYL PHTHALATE C ₆ H ₄ (COOC ₄ H ₉) ₂	ANY METAL	ALL	350	PTFE	ALL	350	
			EPDM	ALL	200		
			Butyl	ALL	200		
DYES	ST. STL.	ALL	350	PTFE	ALL	350	Choice depends on solvent *Use Glass lined DI above 325° F
	GLASS	ALL	350*	EPDM	ALL	250	
	PFA	ALL	350	Butyl	ALL	225	
	ETFE	ALL	300	Nitrile	ALL	180	
EDIBLE OILS							See "Oils, Edible"
EMULSIFIED OILS (AQUEOUS)							See "Oil, Emulsified"
EPICHLORHYDRIN CH ₂ OCHCH ₂ Cl	ST. STL.	ALL	350	PTFE	ALL	350	*Use Glass lined DI above 325° F
	GLASS	ALL	350*				
	PFA	ALL	200				
	ETFE	ALL	200				
ESSENTIAL OILS							See "Oil, Essential"
ESTERS, ORGANIC (IN GENERAL)	ANY METAL	ALL	350	PTFE	ALL	350	Elastomers possible, check ester
	PFA	ALL	250				
	ETFE	ALL	250				
ETHER (IN GENERAL) (C ₂ H ₅) ₂ O	ANY METAL	ALL	350	PTFE	ALL	350	If moisture present, use Stainless Steel or Bronze *Use Glass lined DI above 325° F
	GLASS	ALL	350*				
	PFA	ALL	212				
	ETFE	ALL	212				
	POLYPROP	ALL	75				
ETHYL ACETATE CH ₃ COOC ₂ H ₅	ANY METAL	ALL	350	PTFE	ALL	350	
	PFA	ALL	200				
	ETFE	ALL	150				
ETHYLAMINE CH ₃ CH ₂ NH ₂	ANY METAL	ALL	350	PTFE	ALL	350	*Use Glass lined DI above 325° F
	GLASS	ALL	350*				
ETHYL BROMIDE C ₂ H ₅ Br	ST. STL.	ALL	350	PTFE	ALL	350	*Use Glass lined DI above 325° F
	GLASS	ALL	350*				
	PFA	ALL	350				
	ETFE	ALL	300				
ETHYL CELLOSOLVE C ₄ H ₁₀ O ₂	ANY METAL	ALL	350	PTFE	ALL	350	
ETHYLENEDIAMINE C ₂ H ₄ (NH ₂) ₂	ANY METAL	ALL	350	PTFE	ALL	350	
				EPDM	ALL	200	
				Butyl	ALL	200	
					ALL	180	
ETHYLENE DICHLORIDE C ₂ H ₄ CL ₂	ST. STL.	ALL	350	PTFE	ALL	350	*Use Glass lined DI above 325° F
	GLASS	ALL	350*				
	PFA	ALL	350				
	ETFE	ALL	300				
	PVDF	ALL	275				

Service Guide

SERVICE	BODY			DIAPHRAGM			REMARKS
	MATERIAL	MAXIMUM		MATERIAL	MAXIMUM		
		CONC BY WT	TEMP °F		CONC BY WT	TEMP °F	
ETHYLENE GLYCOL (ANTIFREEZE) $C_2H_4(OH)_2$	ANY METAL	ALL	350	PTFE	ALL	350	
	PFA	ALL	350	EPDM	ALL	275	
	ETFE	ALL	300	Nitrile	ALL	180	
	PVDF	ALL	285				
	POLYPROP	ALL	200				
	CPVC	ALL	190				
ETHYLENE OXIDE C_2H_4O	ST. STL.	ALL	350	PTFE	ALL	350	
	PFA	ALL	230				
	ETFE	ALL	230				
	PVDF	5	200				
FATTY ACIDS (in General) $C_nH_{2n+1}COOH$	ST. STL.	ALL	350	PTFE Nitrile Butyl	ALL ALL ALL	350 180 125	Butyl best for low molecular weight *Use Glass lined DI above 325° F
	GLASS	ALL	350*				
	PFA	ALL	350				
	ETFE	ALL	300				
	PVDF	ALL	285				
	CPVC	ALL	190				
	POLYPROP	ALL	150				
	PVC	ALL	140				
FERRIC CHLORIDE $FeCl_3$	GLASS	ALL	350*	PTFE EPDM Butyl Neoprene	ALL ALL ALL ALL	350 250 225 200	*Use Glass lined DI above 325° F
	PFA	ALL	350				
	ETFE	50	300				
	PVDF	50	285				
	Hard Rubber	ALL	200				
	POLYPROP	50	200				
	CPVC	ALL	190				
	PVC	ALL	140				
FERROUS SALTS	GLASS	ALL	350*	PTFE EPDM Butyl Neoprene	ALL ALL ALL ALL	350 275 250 180	*Use Glass lined DI above 325° F
	PFA	ALL	350				
	ETFE	ALL	300				
	PVDF	ALL	275				
	POLYPROP	ALL	200				
	Hard Rubber	ALL	200				
	CPVC	ALL	190				
	PVC	ALL	140				
FERTILIZER SOLUTIONS	C. I.	ALL	350	PTFE EPDM Butyl Neoprene	ALL ALL ALL ALL	350 250 225 200	Avoid Cl if pH is lower than 7
	ST. STL.	ALL	350				
	PFA	ALL	250				
	ETFE	ALL	250				
	Chlorobutyl	ALL	180				
	PVC	ALL	140				
FLOTATION SOLUTIONS	ANY METAL	ALL	350	PTFE Nitrile	ALL ALL	350 180	
FLUOBORIC ACID HBF_4	PFA	ALL	250	PTFE EPDM Butyl	ALL ALL ALL	250 250 225	
	ETFE	ALL	250				
	Hard Rubber	ALL	200				
	CPVC	ALL	190				
	PVC	ALL	140				
	PVDF	ALL	250				
FLUORIDE SALTS	PFA	ALL	250	EPDM Butyl Neoprene	ALL ALL ALL	250 225 200	
	ETFE	ALL	250				
	Hard Rubber	ALL	200				
	PVC	ALL	140				

Service Guide

SERVICE	BODY			DIAPHRAGM			REMARKS
	MATERIAL	MAXIMUM		MATERIAL	MAXIMUM		
		CONC BY WT	TEMP °F		CONC BY WT	TEMP °F	
FLUOSILICIC ACID H ₂ Si F ₆	PFA	ALL	250	PTFE	ALL	250	
	ETFE	ALL	250	Butyl EPDM	ALL	200	
	Hard Rubber	ALL	200		ALL	200	
	POLYPROP	ALL	200				
	CPVC	25	190				
	PVC	ALL	140				
	PVDF	ALL	250				
FLY ASH	Soft Rubber	ALL	150	EPDM	ALL	150	Use straightway valve above 25% solids
	C. I.	ALL	150	Natural Rubber	ALL	150	
FORMALDEHYDE HCHO	BRONZE	ALL	350	PTFE	ALL	350	*Use Glass lined DI above 325° F
	ST. STL.	ALL	350	Viton	37	175	
	GLASS	ALL	350*	Butyl	37	150	
	PFA	ALL	230	Neoprene	37	80	
	ETFE	37	230				
	Hard Rubber	40	180				
	CPVC	ALL	140				
	POLYPROP	35	75				
	PVDF	37	125				
FORMIC ACID HCOOH	GLASS	ALL	350*	PTFE	ALL	350	*Use Glass lined DI above 325° F
	PFA	ALL	250	Butyl	ALL	200	
	ETFE	ALL	250	Nitrile	ALL	100	
	PVDF	ALL	250				
	ST. STL.	90	160				
	PVC	50	140				
	POLYPROP	85	75				
FREON #11, #12, #113	ST. STL.	ALL	350	PTFE	ALL	350	Body material recommendations are in descending order of resistance
	C.STL.	ALL	350	Nitrile	ALL	130	
	D.I.	ALL	122				
	BRONZE	ALL	350				
	PVDF	ALL	200				
FREON #13, #114, #115 #C318	ST. STL.	ALL	350	PTFE	ALL	350	Body material recommendations are in descending order of resistance
	C.STL.	ALL	350	Nitrile	ALL	130	
	D.I.	ALL	350	Neoprene	ALL	130	
	BRONZE	ALL	350	Butyl	ALL	130	
	PVDF	ALL	200				
FREON #21	ST. STL.	ALL	350	PTFE	ALL	350	Body material recommendations are in descending order of resistance
	C.STL.	ALL	350				
	D.I.	ALL	350				
	BRONZE	ALL	350				
	PVDF	ALL	200				
FREON #22	ST. STL.	ALL	350	PTFE	ALL	350	Body material recommendations are in descending order of resistance
	C.STL.	ALL	350	Neoprene	ALL	130	
	D.I.	ALL	350				
	BRONZE	ALL	350				
	PVDF	ALL	200				
FUEL OIL (ACID FREE)	ANY METAL	ALL	350	PTFE	ALL	350	Use travel stops with elastomer diaphragms; Nitrile and Neoprene not suitable if aromatics present
	PFA	ALL	350	Nitrile	ALL	180	
	ETFE	ALL	300	Neoprene	ALL	160	
	PVDF	ALL	285				
FURFURAL C ₄ H ₃ OCHO	ANY METAL	ALL	350	PTFE	ALL	350	*Use Glass lined DI above 325° F
	GLASS	ALL	350*				
	PFA	ALL	212				
	ETFE	ALL	212				

Service Guide

SERVICE	BODY			DIAPHRAGM			REMARKS
	MATERIAL	MAXIMUM		MATERIAL	MAXIMUM		
		CONC BY WT	TEMP °F		CONC BY WT	TEMP °F	
GALLIC ACID $C_6H_2(OH)_3CO_2H \cdot H_2O$	ST. STL.	ALL	350	PTFE	ALL	350	Check solvent *Use Glass lined DI above 325° F
	GLASS	ALL	350*	EPDM	ALL	150	
	PFA	ALL	210	Butyl	ALL	150	
	ETFE	ALL	210				
	POLYPROP	ALL	150				
	PVC	ALL	140				
Gas, Natural	ANY METAL	ALL	300	PTFE	ALL	300	
	PVDF	ALL	285	Nitrile	ALL	180	
Gas, Propane C_3H_8	ANY METAL	ALL	200	PTFE	ALL	285	
	PVDF	ALL	285	Nitrile	ALL	180	
GASOLINE (ACID FREE)	ANY METAL	ALL	350	PTFE	ALL	350	Use travel stops with elastomer diaphragms; If aromatics present, use Viton or PTFE
	PFA	ALL	350	Nitrile	ALL	180	
	ETFE	ALL	300	Viton	ALL	150	
	PVDF	ALL	285				
	CPVC	ALL	80				
GASOLINE, SOUR	ST. STL.	ALL	350	PTFE	ALL	350	Use travel stops with elastomer diaphragms; If aromatics present, use Viton or PTFE
	GLASS	ALL	350*	Nitrile	ALL	180	
	PFA	ALL	350	Viton	ALL	150	
	ETFE	ALL	300				
	PVDF	ALL	285				
GELATIN	BRONZE	ALL	350	PTFE	ALL	350	
	ST. STL.	ALL	350	Butyl	ALL	250	
	PFA	ALL	350	EPDM	ALL	250	
	ETFE	ALL	300	White Butyl	ALL	225	
	POLYPROP	ALL	150				
	PVC	ALL	140				
	PVDF	ALL	250				
GLUE	ANY METAL	ALL	350	PTFE	ALL	350	Glass and PTFE preferred if lines are not cleaned regularly; Check solvent used to clean lines; *Use Glass lined DI above 325° F **For use of any elastomer diaphragm, see temperature limit and check solvent.
	GLASS	ALL	350*	**	ALL	**	
	PVDF	ALL	250				
GLUTAMIC ACID $C_5H_9NO_4$	ST. STL.	ALL	350	PTFE	ALL	350	Check solvent. *Use Glass lined DI above 325° F.
	GLASS	ALL	350*	Butyl	ALL	225	
	PFA	ALL	350	EPDM	ALL	150	
	ETFE	ALL	300	Nitrile	ALL	180	
	PVC	ALL	140				
	PVDF	ALL	200				
GLYCERIN $C_3H_5(OH)_3$	ANY METAL	ALL	350	PTFE	ALL	350	Cl May Rust *Use Glass lined DI above 325° F
	GLASS	ALL	350*	EPDM	ALL	300	
	PVDF	ALL	285	Butyl	ALL	250	
	CPVC	ALL	190	Nitrile	ALL	180	
	PVC	ALL	140	Natural Rubber	ALL	180	
	POLYPROP	ALL	130				

Service Guide

SERVICE	BODY			DIAPHRAGM			REMARKS
	MATERIAL	MAXIMUM		MATERIAL	MAXIMUM		
		CONC BY WT	TEMP °F		CONC BY WT	TEMP °F	
GLYCOL CH ₂ OHCH ₂ OH	ANY METAL	ALL	350	PTFE	ALL	350	Cl will rust if moisture present *Use Glass lined DI above 325° F
	GLASS	ALL	350*	EPDM	ALL	275	
	PFA	ALL	350	Butyl	ALL	200	
	ETFE	ALL	300	Hypalon	ALL	200	
	PVDF	ALL	285	Nitrile	ALL	150	
	Hard Rubber	ALL	200				
	POLYPROP	ALL	150				
GYPSUM SLURRY Ca SO ₄ • 2 H ₂ O	GLASS	ALL	275	EPDM	ALL	150	Very abrasive; Check chloride content
	Hard Rubber	ALL	200	Natural Rubber	ALL	150	
	Soft Rubber	ALL	150				
HELIUM He	D.I.	ALL	250	Butyl	ALL	250	See "Inert Gases"
HEXANE C ₆ H ₁₄	ANY METAL	ALL	350	PTFE	ALL	350	Use travel stops with Nitrile
	PFA	ALL	350	Nitrile	ALL	150	
	ETFE	ALL	300				
	PVDF	ALL	285				
	PVC	ALL	140				
HYDRAZINE H ₂ NNH ₂	ST. STL.	ALL	350	PTFE	ALL	350	*Use Glass lined DI above 325° F UDMH – check under "U"
	GLASS	ALL	350*	EPDM	ALL	75	
	PFA	ALL	100				
	ETFE	ALL	100				
HYDROCHLORIC ACID HCl	GLASS*	ALL	300	PTFE**	ALL	350	**If contaminated with hydrocarbons
	PFA**	37	350	Viton	37	150	
	ETFE	37	300				
	PVDF**	37	285	Butyl	37	100	
	Hard Rubber	37	180	EPDM	37	100	
	POLYPROP	30	170				
	PVC	35	140				
	CPVC	35	200				
HYDROCYANIC ACID HCN	GLASS	ALL	350*	PTFE	ALL	350	*Use Glass DI above 325° F
	ST. STL.	ALL	350	Butyl	ALL	150	
	PFA	ALL	350	EPDM	ALL	150	
	ETFE	ALL	300	Viton	ALL	150	
	PVDF	ALL	275	Hypalon	ALL	100	
	Hard Rubber	ALL	180	Neoprene	ALL	100	
	POLYPROP	ALL	150				
	PVC	ALL	140				
HYDROFLUORIC ACID HF	PFA	ALL	250	PTFE	ALL	250	See page 164
	ETFE	ALL	250				
	PVDF	ALL	200	Butyl	50	100	
	POLYPROP	40	150	EPDM	50	100	
	MONEL	48	176	Viton	75	150	
	Chlorobutyl	70	100				
	PVC	50	75				
HYDROGEN CHLORIDE GAS (DRY) HCl	GLASS	ALL	350*	PTFE	ALL	350	
	PFA	ALL	275				
	ETFE	ALL	275				
	PVDF	ALL	275				
	POLYPROP	ALL	150				
HYDROGEN PEROXIDE H ₂ O ₂	GLASS	ALL	350*	PTFE	ALL	350	Vapor pressure depends on temperature *Use Glass lined DI above 325° F
	ST. STL.	ALL	350				
	PFA	ALL	200	EPDM	30	80	
	ETFE	90	150				
	POLYPROP	28	75				
	PVDF	30	200				

Service Guide

SERVICE	BODY			DIAPHRAGM			REMARKS
	MATERIAL	MAXIMUM		MATERIAL	MAXIMUM		
		CONC BY WT	TEMP °F		CONC BY WT	TEMP °F	
HYDROGEN SULFIDE (AQUEOUS) H ₂ S + H ₂ O	GLASS	ALL	350*	PTFE	ALL	350	*Use Glass lined DI above 325° F
	PFA	ALL	350	Viton	ALL	200	
	ETFE	ALL	300	Butyl	ALL	100	
	PVDF	ALL	275	EPDM	ALL	100	
	POLYPROP	ALL	175				
	Hard Rubber	ALL	150				
	PVC	ALL	140				
HYPOCHLORITE (BLEACH)							See individual type such as sodium hypochlorite
HYPO (PHOTOGRAPHY)							Sodium Thiosulphate; See developing solutions
HYPOCHLOROUS ACID HOCl	GLASS	ALL	350*	PTFE	ALL	350	*Use Glass lined DI above 325° F
	PFA	ALL	250				
	ETFE	ALL	250				
	PVDF	ALL	70				
	Hard Rubber	ALL	180				
	POLYPROP	ALL	75				
ICE CREAM	BRONZE	ALL	250	Butyl	ALL	250	
	ST. STL.	ALL	250	White Butyl	ALL	225	
	PVC	ALL	140				
	PVDF	ALL	250				
INERT GASES (ARGON, HELIUM, KRYPTON, NEON, RADON, XENON)	D.I.	ALL	350	PTFE	ALL	350	Avoid porous metals
	BRONZE	ALL	350	EPDM	ALL	300	
	C.STL.	ALL	350	Butyl	ALL	250	
	PFA	ALL	350				
	ETFE	ALL	300				
	PVC	ALL	140				
	PVDF	ALL	285				
INK	BRONZE	ALL	350	PTFE	ALL	350	Check solvent *Use Glass lined DI above 325° F
	ST. STL.	ALL	350	EPDM	ALL	250	
	GLASS	ALL	350*	Butyl	ALL	250	
	PVDF	ALL	285				
INSECTICIDE	GLASS	ALL	350*	PTFE	ALL	350	Use of Nitrile possible, check solvent first; metals possible, check with factory *Use Glass lined DI above 325° F
	PFA	ALL	275				
	ETFE	ALL	275				
	PVDF	ALL	200				
IODINE I ₂	GLASS	ALL	350*	PTFE	ALL	350	Check carrier *Use Glass lined DI above 325° F
	ST. STL.	ALL	350	EPDM	ALL	250	
	PFA	ALL	230	Butyl	ALL	225	
	ETFE	ALL	230				
	PVDF	ALL	150				
	POLYPROP	ALL	75				
IRON OXIDE Fe ₂ O ₃	Soft Rubber	ALL	150	EPDM	ALL	150	Check carrier; can be very abrasive
				Natural Rubber	ALL	150	
JAMS & JELLIES	ST. STL.	ALL	350	PTFE	ALL	350	*Use Glass lined DI above 325° F
	GLASS	ALL	350*	EPDM (FDA)	ALL	250	
	PFA	ALL	350	Butyl	ALL	250	
	ETFE	ALL	300	White Butyl	ALL	225	
	PVC	ALL	140	Nitrile	ALL	100	
	PVDF	ALL	285				

Service Guide

SERVICE	BODY			DIAPHRAGM			REMARKS
	MATERIAL	MAXIMUM		MATERIAL	MAXIMUM		
		CONC BY WT	TEMP °F		CONC BY WT	TEMP °F	
JET FUELS	ANY METAL PFA ETFE PVDF CPVC	ALL ALL ALL ALL ALL	350 230 230 200 140	PTFE Viton Nitrile	ALL ALL ALL	350 250 180	Use travel stops with elastomer diaphragms
JUICE (FRUIT & VEGETABLE)	ST. STL. GLASS PFA ETFE PVC PVDF	ALL ALL ALL ALL ALL ALL	350 350* 275 275 140 275	PTFE Butyl White Butyl	ALL ALL ALL	350 250 225	*Use Glass lined DI above 325° F
JUICE, CITRIC							See "Citric Acid"
KAOLIN	PFA ETFE Soft Rubber PVC	ALL ALL ALL ALL	275 275 150 140	EPDM Natural Rubber	ALL ALL	275 180	Check carrier
KEROSENE	ANY METAL PFA ETFE PVDF CPVC PVC	ALL ALL ALL ALL ALL ALL	350 350 300 285 190 140	PTFE Viton Nitrile	ALL ALL ALL	350 150 180	Use travel stops with elastomer diaphragms
LACTIC ACID CH ₃ CHOHCOOH	GLASS PFA ETFE Hard Rubber ST. STL. POLYPROP PVDF	ALL ALL ALL ALL ALL ALL ALL	350* 250 250 180 160 150 100	PTFE Viton EPDM Neoprene	ALL ALL ALL 80	350 200 150 150	*Use Glass lined DI above 325° F
LARD	ANY METAL PFA ETFE PVDF CPVC POLYPROP PVC	ALL ALL ALL ALL ALL ALL ALL	350 350 300 285 190 175 140	PTFE Nitrile	ALL ALL	350 180	Use travel stops with elastomer diaphragms
LATEX	C. I. GLASS ST. STL. PFA ETFE Hard Rubber	ALL ALL ALL ALL ALL ALL	350 350* 350 350 300 200	PTFE EPDM Neoprene	ALL ALL ALL	350 200 150	Smooth bodies and diaphragms preferred to eliminate sticking *Use Glass lined DI above 325° F
LAUNDRY WASH WATER	ANY METAL PFA ETFE PVDF POLYPRO	ALL ALL ALL ALL ALL	250 250 250 250 200	EPDM Butyl Nitrile	ALL ALL ALL	250 225 180	
LEAD ACETATE Pb (C ₂ H ₃ O ₂) ₂ • 3H ₂ O	GLASS ST. STL. PFA ETFE POLYPROP PVDF	ALL ALL ALL ALL ALL ALL	350* 350 350 300 175 275	PTFE EPDM Butyl	ALL ALL ALL	350 150 100	*Use Glass lined DI above 325° F

Service Guide

SERVICE	BODY			DIAPHRAGM			REMARKS
	MATERIAL	MAXIMUM		MATERIAL	MAXIMUM		
		CONC BY WT	TEMP °F		CONC BY WT	TEMP °F	
LEAD ARSENATE $Pb_3(AsO_4)_2$	C.I.	ALL	250	EPDM	ALL	250	Check carrier
	PFA	ALL	250	Neoprene	ALL	200	
	ETFE	ALL	250				
	Neoprene	ALL	200				
	Soft Rubber	ALL	150				
LEAD OXIDE Pb_3O_4	C.I.	ALL	250	EPDM	ALL	250	Check carrier
	PFA	ALL	250	Neoprene	ALL	200	
	ETFE	ALL	250				
	Neoprene	ALL	200				
	Soft Rubber	ALL	150				
	PVDF	ALL	200				
LEAD TETRAETHYL $Pb(C_2H_5)_4$	GLASS	ALL	350*	PTFE	ALL	350	Extremely poisonous *Use Glass lined DI above 325° F
	PFA	ALL	350				
	ETFE	ALL	300				
	PVDF	ALL	285				
LIME Ca O	C. I .	ALL	250	EPDM	ALL	250	May be abrasive
	PFA	ALL	250	Neoprene	ALL	200	
	ETFE	ALL	250				
	Neoprene	ALL	200				
	Soft Rubber	ALL	150				
	PVDF	ALL	250				
LIMESTONE SLURRY	GLASS	ALL	275	EPDM	ALL	150	Very abrasive; Check chloride content
	Hard Rubber	ALL	200	Natural Rubber	ALL	150	
	Soft Rubber	ALL	150				
LITHIUM SALTS	ANY METAL	ALL	350	PTFE	ALL	350	*Use Glass lined DI above 325° F
	GLASS	ALL	350*	EPDM	ALL	300	
	PFA	ALL	350	Butyl	ALL	225	
	ETFE	ALL	300	Neoprene	ALL	180	
	Hard Rubber	ALL	200				
	Neoprene	ALL	200				
	PVC	ALL	140				
	PVDF	ALL	220				
MAGNESIUM CARBONATE $MgCO_3$	ANY METAL	ALL	350	PTFE	ALL	350	If in solution, check acid before using metal
	PFA	ALL	350	EPDM	ALL	250	
	ETFE	ALL	300	Butyl	ALL	225	
	PVDF	ALL	285	Neoprene	ALL	160	
	POLYPROP	ALL	200				
	PVC	ALL	140				
MAGNESIUM CHLORIDE $MgCl_2 \cdot 6H_2O$	GLASS	ALL	350*	PTFE	ALL	350	*Use Glass lined DI above 325° F
	PFA	ALL	350	EPDM	ALL	250	
	ETFE	ALL	300	Butyl	ALL	225	
	PVDF	ALL	285				
	POLYPROP	ALL	200				
	CPVC	ALL	190	Neoprene	ALL	160	
	Hard Rubber	ALL	150				
MAGNESIUM HYDROXIDE $Mg(OH)_2$	ANY METAL	ALL	350	PTFE	ALL	350	
	PFA	ALL	350	EPDM	ALL	275	
	ETFE	ALL	300	Butyl	ALL	250	
	PVDF	ALL	275	Neoprene	ALL	160	
	POLYPROP	ALL	200				
	Chlorobutyl	ALL	150				
	PVC	ALL	140				

Service Guide

SERVICE	BODY			DIAPHRAGM			REMARKS
	MATERIAL	MAXIMUM		MATERIAL	MAXIMUM		
		CONC BY WT	TEMP °F		CONC BY WT	TEMP °F	
MAGNESIUM OXIDE	ANY METAL Neoprene Soft Rubber PVC	ALL ALL ALL ALL	350 200 150 150	PTFE EPDM Butyl	ALL ALL ALL	350 300 250	Check carrier
MAGNESIUM SULFATE Mg SO ₄	ST. STL. PFA ETFE PVDF Hard Rubber POLYPROP	ALL ALL ALL ALL ALL ALL	350 350 300 275 200 200	PTFE EPDM Butyl Neoprene	ALL ALL ALL ALL	350 275 250 200	
MALEIC ACID HOOCCHCHCOOH	ST. STL. GLASS PFA ETFE PVDF POLYPROP	ALL ALL ALL ALL ALL 10	350 350* 275 275 250 150	PTFE EPDM Butyl	ALL ALL ALL	350 150 150	*Use Glass lined DI above 325° F
MERCURY SALTS	GLASS PFA ETFE PVDF Hard Rubber CPVC PVC	ALL ALL ALL ALL ALL ALL ALL	350* 275 275 250 200 190 140	PTFE EPDM Butyl	ALL ALL ALL	350 250 225	*Use Glass lined DI above 325° F
METHANOL							See "Alcohol, Methyl"
METHYL ETHYL KETONE (MEK) CH ₃ COC ₂ H ₅	ANY METAL PFA ETFE	ALL ALL ALL	350 230 230	PTFE EPDM	ALL ALL	350 200	
METHYL ISOBUTYL KETONE (MIBK) (CH ₃) ₂ CHCH ₂ COCH ₃	ANY METAL PFA ETFE	ALL ALL ALL	350 230 230	PTFE EPDM	ALL ALL	350 200	
METHYL METHACRYLATE SLURRY C ₄ H ₆ O ₂	GLASS PFA ETFE POLYPROP PVC PVDF	ALL ALL ALL ALL ALL ALL	350* 220 220 150 140 125	PTFE	ALL	350	*Use Glass lined DI above 325° F
METHYLENE CHLORIDE CH ₂ Cl ₂	ST. STL. GLASS PFA ETFE PVDF	ALL ALL ALL ALL ALL	350 350* 212 212 125	PTFE	ALL	350	*Use Glass lined DI above 325° F
MILK	ST. STL. GLASS PVDF	ALL ALL ALL	350 350* 250	PTFE White Butyl	ALL ALL	350 225	*Use Glass lined DI above 325° F
MIXED ACID							Advise Acids, Concen & Temp
MOLASSES	ST. STL. POLYPROP PVDF	ALL ALL ALL	350 200 175	PTFE Butyl White Butyl	ALL ALL ALL	350 250 225	
MONOCHLORO- ACETIC ACID CH ₂ Cl COOH	GLASS HASTELLOY-C PFA ETFE POLYPROP Hard Rubber PVC	ALL ALL ALL ALL ALL ALL ALL	350* 350 230 230 175 150 140	PTFE EPDM	ALL 50	350 150	*Use Glass lined DI above 325° F

Service Guide

SERVICE	BODY			DIAPHRAGM			REMARKS
	MATERIAL	MAXIMUM		MATERIAL	MAXIMUM		
		CONC BY WT	TEMP °F		CONC BY WT	TEMP °F	
MUD	C. I.	ALL	250	EPDM*	ALL	250	*No oil present
	Soft Rubber	ALL	150	Natural Rubber	ALL	180	
MURIATIC ACID							See "Hydrochloric Acid"
MUSTARD (FOOD)	ST. STL.	ALL	350	PTFE	ALL	350	*Use Glass lined DI above 325° F
	GLASS	ALL	350*	Butyl	ALL	250	
	PFA	ALL	350	White Butyl	ALL	225	
	ETFE	ALL	300				
	PVDF	ALL	275				
NAPHTHA	ANY METAL	ALL	350	PTFE	ALL	350	Use travel stops with Nitrile; Nitrile for use with aliphatics only. *Use Glass lined DI above 325° F
	GLASS	ALL	350*	Nitrile	ALL	120	
	PFA	ALL	350	Viton	ALL	160	
	ETFE	ALL	300				
	PVDF	ALL	275				
	CPVC	ALL	140				
NICKEL CHLORIDE (AQUEOUS) Ni Cl ₂	GLASS	ALL	350*	PTFE	ALL	350	*Use Glass lined DI above 325° F
	MONEL	ALL	350	EPDM	ALL	250	
	PFA	ALL	350	Butyl	ALL	150	
	ETFE	ALL	300				
	PVDF	ALL	285				
	Hard Rubber	ALL	200				
	POLYPROP	ALL	150				
NICKEL PLATING SOLUTIONS	GLASS	ALL	350*	PTFE	ALL	350	*Use Glass lined DI above 325° F
	MONEL	ALL	350				
	PFA	ALL	350	EPDM	ALL	175	
	ETFE	ALL	300	Butyl	ALL	150	
	PVDF	ALL	285				
	Hard Rubber	ALL	150				
	POLYPROP	ALL	150				
NICKEL SALTS	GLASS	ALL	350*	PTFE	ALL	350	*Use Glass lined DI above 325° F
	ST. STL.	ALL	350	EPDM	ALL	250	
	PFA	ALL	350	Butyl	ALL	200	
	ETFE	ALL	300				
	PVDF	ALL	275	Neoprene	ALL	150	
	Hard Rubber	ALL	200				
	POLYPROP	ALL	150				
NICKEL SULFATE Ni SO ₄	GLASS	ALL	350*	PTFE	ALL	350	*Use Glass lined DI above 325° F
	ST. STL.	ALL	350	EPDM	ALL	250	
	PFA	ALL	350	Butyl	ALL	225	
	ETFE	ALL	300				
	PVDF	ALL	285				
	Hard Rubber	ALL	200				
	POLYPROP	ALL	200				
NITRIC ACID HNO ₃ B.P. 187°F	GLASS	ALL	187	PTFE	ALL	187	
	PFA	TO 50	187	Viton	60	80	
	ETFE	TO 50	187				
	PVDF	TO 50	150				
	CN7M	TO 70	187				
	ST. STL.	TO 50	150				
	ETFE	TO 70	140				
	POLYPROP	TO 10	140				
	PVC	TO 10	70				

Service Guide

SERVICE	BODY			DIAPHRAGM			REMARKS
	MATERIAL	MAXIMUM		MATERIAL	MAXIMUM		
		CONC BY WT	TEMP °F		CONC BY WT	TEMP °F	
NITROCELLULOSE C ₆ H ₇ O ₅ (NO ₂) ₃	ANY METAL GLASS PFA ETFE	ALL ALL ALL ALL	350 350* 210 210	PTFE	ALL	350	For elastomer diaphragms, check solvent *Use Glass lined DI above 325° F
NITROGEN GAS N ₂	D.I. C.STL. BRONZE PFA ETFE PVC PVDF	ALL ALL ALL ALL ALL ALL ALL	350 350 350 250 250 140 285	PTFE Butyl Neoprene	ALL ALL ALL	350 225 200	Avoid porous metals
NITROGEN SOLUTIONS	C. I. D. I. ST. STL. PFA ETFE Hard Rubber PVC	ALL ALL ALL ALL ALL ALL ALL	350 350 350 250 250 200 140	PTFE EPDM Butyl Neoprene	ALL ALL ALL ALL	350 250 225 200	
NITROGLYCERIN CH ₂ NO ₃ CHNO ₃ CH ₂ NO ₃	ST. STL. GLASS PFA ETFE PVDF	ALL ALL ALL ALL ALL	350 350* 250 250 125	PTFE	ALL	350	*Use Glass lined DI above 325° F; Use at customer's risk
NITROPARAFFINS	ANY METAL GLASS PFA ETFE	ALL ALL ALL ALL	350 350* 250 250	PTFE	ALL	350	*Use Glass lined DI above 325° F
OAKITE	C. I. GLASS ST. STL. RUBBER* PLASTIC*	ALL ALL ALL * *	350 350** 350 * *	PTFE EPDM Butyl Nitrile	ALL ALL ALL ALL	350 250 225 180	*Due to numerous compounds, obtain specific data or number **Use Glass lined DI above 325° F
OIL, CASTOR	BRONZE ST. STL. PFA ETFE PVDF CPVC POLYPROP	ALL ALL ALL ALL ALL ALL ALL	350 350 350 300 285 190 150	PTFE Nitrile	ALL ALL	350 180	Use travel stops with elastomer diaphragms
OIL, COCONUT	BRONZE ST. STL. PFA ETFE PVDF POLYPROP	ALL ALL ALL ALL ALL ALL	350 350 350 300 285 150	PTFE Nitrile	ALL ALL	350 180	Use travel stops with elastomer diaphragms
OIL, CRUDE	BRONZE ST. STL. PFA ETFE PVDF PVC	ALL ALL ALL ALL ALL ALL	350 350 350 300 285 140	PTFE Nitrile Neoprene Viton	ALL ALL ALL ALL	350 150 180 200	Use travel stop with elastomer diaphragms

Service Guide

SERVICE	BODY			DIAPHRAGM			REMARKS					
	MATERIAL	MAXIMUM		MATERIAL	MAXIMUM							
		CONC BY WT	TEMP °F		CONC BY WT	TEMP °F						
OILS, EDIBLE	ST. STL.	ALL	350	PTFE	ALL	350	*Use Glass lined DI above 325° F					
	GLASS	ALL	350*									
	PFA	ALL	350									
	ETFE	ALL	300									
	POLYPROP	ALL	150									
	PVC	ALL	140									
	PVDF	ALL	285									
OIL, EMULSIFIED	ANY METAL	ALL	350	PTFE Viton Nitrile	ALL ALL ALL	350 250 180	Use travel stops with elastomer diaphragms					
	PFA	ALL	350									
	ETFE	ALL	300									
	PVDF	ALL	285									
	CPVC	ALL	190									
	PVC	ALL	140									
	OIL, LINSEED	ANY METAL	ALL					350	PTFE Viton Nitrile	ALL ALL ALL	350 150 150	Use travel stops with elastomer diaphragms
PFA		ALL	350									
ETFE		ALL	300									
PVDF		ALL	285									
PVC		ALL	140									
OIL, LUBRICATING		ANY METAL	ALL	350	PTFE Viton Nitrile	ALL ALL ALL	350 200 150	Use travel stops with elastomer diaphragms				
	PFA	ALL	350									
	ETFE	ALL	300									
	PVDF	ALL	285									
	PVC	ALL	140									
	OIL, MINERAL	ANY METAL	ALL	350					PTFE Nitrile	ALL ALL	350 180	Use travel stops with elastomer diaphragms *Use Glass lined DI above 325° F
GLASS		ALL	350*									
PFA		ALL	350									
ETFE		ALL	300									
PVDF		ALL	285									
PVC		ALL	140									
OIL, OLIVE		BRONZE	ALL	350	PTFE Nitrile	ALL ALL	350 180	Use travel stops with elastomer diaphragms				
	PFA	ALL	350									
	ETFE	ALL	300									
	PVDF	ALL	250									
	CPVC	ALL	190									
	PVC	ALL	140									
	OIL, SOYBEAN	ANY METAL	ALL	350					PTFE Viton Nitrile	ALL ALL ALL	350 250 180	Use travel stops with elastomer diaphragms
PFA		ALL	350									
ETFE		ALL	300									
PVC		ALL	140									
PVDF		ALL	275									
OIL, VEGETABLE		BRONZE	ALL	350	PTFE Nitrile	ALL ALL	350 180	Use travel stops with elastomer diaphragms *Use Glass lined DI above 325° F				
		ST. STL.	ALL	350								
	GLASS	ALL	350*									
	PFA	ALL	350									
	ETFE	ALL	300									
	PVDF	ALL	285									
	OLEIC ACID C ₁₇ H ₃₃ COOH	ST. STL.	ALL	350					PTFE Butyl Nitrile	ALL ALL ALL	350 200 150	
		MONEL	ALL	350								
PFA		ALL	275									
ETFE		ALL	275									
PVDF		ALL	250									
PVC		ALL	140									

Service Guide

SERVICE	BODY			DIAPHRAGM			REMARKS
	MATERIAL	MAXIMUM		MATERIAL	MAXIMUM		
		CONC BY WT	TEMP °F		CONC BY WT	TEMP °F	
OLEUM							See "Sulfuric Acid, Fuming"
OXALIC ACID C ₂ H ₂ O ₄ • 2H ₂ O	GLASS PFA ETFE CN7M CPVC POLYPROP Hard Rubber PVC PVDF	ALL ALL ALL ALL ALL ALL ALL ALL ALL	350* 250 250 250 190 150 150 140 125	PTFE EPDM Butyl	ALL 50 50	350 200 200	*Use Glass lined DI above 325° F
OXYGEN (GAS) O ₂	ANY METAL* PFA ETFE PVDF POLYPROP PVC	ALL ALL ALL ALL ALL ALL	100 100 100 100 100 100	PTFE EPDM Neoprene Butyl White Butyl	ALL ALL ALL ALL ALL	100 100 100 100 100	*Avoid porous metals Special lubricant required; Must specify for O ₂ service
OZONE O ₃	D. I. BRONZE ST. STL. PFA ETFE PVDF PVC	ALL ALL ALL ALL ALL ALL ALL	250 250 250 250 250 225 140	PTFE EPDM	ALL 3	250 150	
PAINT (LINSEED BASE)	ANY METAL GLASS PFA ETFE	ALL ALL ALL ALL	350 350* 275 275	PTFE Nitrile	ALL ALL	350 100	For Nitrile, check solvent first and recommend travel stops *Use Glass lined DI above 325° F
PAINT (WATER BASE)	BRONZE ST. STL. PFA ETFE PVC	ALL ALL ALL ALL ALL	350 350 350 300 140	PTFE EPDM Nitrile	ALL ALL ALL	350 250 180	
PAPER CLAY	BRONZE ST. STL. Soft Rubber PVC	ALL ALL ALL ALL	350 350 150 140	PTFE EPDM	ALL ALL	350 275	
PAPER PULP (NO CHLORINE)	ST. STL. GLASS PFA ETFE Soft Rubber	ALL ALL ALL ALL ALL	350 350* 350 300 150	PTFE EPDM	ALL ALL	350 275	*Use Glass lined DI above 325° F
PAPER PULP (CHLORINATED)	GLASS ST. STL. PFA ETFE Hard Rubber	ALL ALL ALL ALL ALL	350* 350 275 275 200	PTFE EPDM	ALL ALL	350 200	*Use Glass lined DI above 325° F
PARAFFIN	ANY METAL GLASS POLYPROP PVDF	ALL ALL ALL ALL	350 350* 140 250	PTFE Nitrile	ALL ALL	350 160	Use travel stops with elastomer diaphragms *Use Glass lined DI above 325° F

Service Guide

SERVICE	BODY			DIAPHRAGM			REMARKS			
	MATERIAL	MAXIMUM		MATERIAL	MAXIMUM					
		CONC BY WT	TEMP °F		CONC BY WT	TEMP °F				
PERCHLORO-ETHYLENE C_2Cl_4	ANY METAL	ALL	350	PTFE Viton	ALL	350	*Use Glass lined DI above 325° F			
	GLASS	ALL	350*		ALL	200				
	PFA	ALL	350							
	ETFE	ALL	300							
	PVDF	ALL	275							
PERFUMES	GLASS	ALL	350*	PTFE	ALL	350	*Use Glass lined DI above 325° F			
	ST. STL.	ALL	350							
	PFA	ALL	275							
	ETFE	ALL	275							
PEROXIDE BLEACH	ST. STL.	ALL	350	PTFE EPDM	ALL 30	350 80	Also see "Hydrogen Peroxide" *Use Glass lined DI above 325° F			
	GLASS	ALL	350*							
	PFA	ALL	350							
	ETFE	ALL	250							
	PVC	ALL	140							
	PVDF	ALL	175							
PETROLEUM	ANY METAL	ALL	350	PTFE Viton Nitrile	ALL	350	Use travel stops with elastomer diaphragms			
	PFA	ALL	350		ALL	200				
	ETFE	ALL	300		ALL	150				
	PVDF	ALL	285							
	PVC	ALL	100							
PETROLEUM ETHER (BENZINE, NAPHTHA)	ANY METAL	ALL	350	PTFE Viton	ALL	350				
	PFA	ALL	225		ALL	100				
	ETFE	ALL	225							
PHARMACEUTICALS	GLASS	ALL	350*	PTFE EPDM Butyl White Butyl	ALL	350	Check carrier; Use of Plastic (ETFE, PFA) based on customer acceptance *Use Glass lined DI above 325° F			
	ST. STL.	ALL	350		ALL	275				
	PFA	ALL	350		ALL	250				
	ETFE	ALL	300		ALL	225				
PHENOL C_6H_5OH	GLASS	ALL	350*	PTFE Viton	ALL	350	*Use Glass lined DI above 325° F			
	ST. STL.	ALL	350		ALL	200				
	PFA	ALL	250							
	ETFE	ALL	250							
	PVDF	ALL	158							
	CPVC	ALL	140							
	POLYPROP	ALL	140							
PHOSPHORIC ACID H_3PO_4	GLASS*	ALL	250	PTFE EPDM Butyl	ALL	350	PTFE if no discoloration permissible *Check for fluorides			
	CN7M	85	350		ALL	225				
	PFA	ALL	275		ALL	200				
	ETFE	ALL	275							
	PVDF	85	225							
	Hard Rubber	ALL	200							
	CPVC	85	190							
	Neoprene	85	180							
	ST. STL.	85	160							
	PVC	50	140							
	POLYPROP	85	140							
	PHOSPHOROUS OXYCHLORIDE $POCl_3$	GLASS	ALL		350*	PTFE		ALL	350	*Use Glass lined DI above 325° F
		PFA	ALL		230					
ETFE		ALL	230							
PHOSPHOROUS TRICHLORIDE PCl_3	GLASS	ALL	350*	PTFE	ALL	350	*Use Glass lined DI above 325° F			
	MONEL	ALL	350							
	PFA	ALL	250							
	ETFE	ALL	250							
	PVDF	ALL	200							

Service Guide

SERVICE	BODY			DIAPHRAGM			REMARKS
	MATERIAL	MAXIMUM		MATERIAL	MAXIMUM		
		CONC BY WT	TEMP °F		CONC BY WT	TEMP °F	
PHTHALIC ANHYDRIDE $C_8H_4O_3$	ST. STL.	ALL	350	PTFE	ALL	350	Check carrier *Use Glass lined DI above 325° F
	GLASS	ALL	350*	Nitrile	ALL	180	
	PFA	ALL	250	EPDM	ALL	180	
	ETFE	ALL	250				
	PVDF	ALL	200				
PICKLING SOLUTIONS							Advise acids, concentrations and temperature
PICRIC ACID $C_6H_2(NO_2)_3OH$	ST. STL.	ALL	350	PTFE	ALL	350	Recommendations for water or alcohol solution *Use Glass lined DI above 325° F
	GLASS	ALL	350*	EPDM	10	80	
	PFA	ALL	250	Butyl	10	80	
	ETFE	ALL	250	Nitrile	10	80	
	PVDF	ALL	75	Neoprene	10	80	
PLATING SOLUTIONS (OTHER THAN CHROMIUM)	GLASS	ALL	350*	PTFE	ALL	350	*Use Glass lined DI above 325° F
	PFA	ALL	275	Butyl	ALL	200	
	ETFE	ALL	250				
	Hard Rubber	ALL	200	EPDM	ALL	200	
	POLYPROP	ALL	150	Neoprene	ALL	175	
	PVC	ALL	140				
	PVDF	ALL	200				
PLATING SOLUTION, CHROMIUM	GLASS	ALL	350*	PTFE	ALL	350	*Use Glass lined DI above 325° F
	PFA	ALL	225				
	ETFE	ALL	225				
	PVDF	ALL	200				
POLIO VACCINE	GLASS	ALL	350*	PTFE	ALL	350	Elastomer diaphragms possible depending on customer *Use Glass lined DI above 325° F
	ST. STL.	ALL	350				
POLYVINYL CHLORIDE SLURRY $(H_2CCHCl)_n$	GLASS	ALL	350*	PTFE	ALL	350	Limited service life on Neoprene diaphragms *Use Glass lined DI above 325° F
	ST. STL.	ALL	350	Neoprene	ALL	180	
	PFA	ALL	225				
	ETFE	ALL	225				
POTASH, CAUSTIC KOH	C. I.	ALL	350	PTFE	ALL	350	*Select materials by temperature limitations
	BRONZE	ALL	350	EPDM	ALL	250	
	ST. STL.	ALL	350				
	ANY PLASTIC	ALL	*	Butyl	ALL	212	
	ANY RUBBER	ALL	*	Neoprene	ALL	200	
POTASSIUM CHROMATE K_2CrO_4	ST. STL.	ALL	350	PTFE	ALL	350	*Use Glass lined DI above 325° F
	GLASS	ALL	350*	EPDM	ALL	250	
	PFA	ALL	350	Butyl	ALL	225	
	ETFE	ALL	300				
	PVDF	ALL	285				
	Neoprene	ALL	200				
	POLYPROP	ALL	175				
	PVC	ALL	140				
POTASSIUM DICHROMATE $K_2Cr_2O_7$						See "Potassium Chromate"	
POTASSIUM HYDROXIDE KOH						See "Potash, Caustic"	

Service Guide

SERVICE	BODY			DIAPHRAGM			REMARKS
	MATERIAL	MAXIMUM		MATERIAL	MAXIMUM		
		CONC BY WT	TEMP °F		CONC BY WT	TEMP °F	
POTASSIUM HYPOCHLORITE KOCI	GLASS	ALL	350*	PTFE EPDM	ALL	350	*Use Glass lined DI above 325° F
	PFA	ALL	350		ALL	125	
	ETFE	ALL	300				
	PVDF	ALL	200				
	Hard Rubber	ALL	200				
	POLYPROP	ALL	175				
	PVC	ALL	140				
POTASSIUM IODIDE KI	ANY METAL	ALL	350	PTFE EPDM Butyl Natural Rubber	ALL	350	*Use Glass lined DI above 325° F
	GLASS	ALL	350*		ALL	300	
	PFA	ALL	350		ALL	250	
	ETFE	ALL	300		ALL	180	
	PVDF	ALL	250				
	POLYPROP	ALL	200				
	PVC	ALL	150				
POTASSIUM NITRATE (SALTPETER) KNO ₃						See "Potassium Salts"	
POTASSIUM PERCHLORATE KCl O ₄	ST. STL.	ALL	350	PTFE EPDM Butyl	ALL	350	*Use Glass lined DI above 325° F
	GLASS	ALL	350*		ALL	125	
	PFA	ALL	350		ALL	100	
	ETFE	ALL	300				
	PVDF	ALL	200				
	POLYPROP	ALL	175				
	PVC	ALL	140				
POTASSIUM PERMANGANATE KMn O ₄	ST. STL.	ALL	350	PTFE EPDM Butyl	ALL	350	*Use Glass lined DI above 325° F
	GLASS	ALL	350*		25	200	
	PFA	ALL	350		25	200	
	ETFE	ALL	300				
	PVDF	ALL	250				
	PVC	ALL	140				
POTASSIUM SALTS (OTHER THAN ABOVE)	C. I.	ALL	350	PTFE EPDM Butyl Neoprene	ALL	350	
	ST. STL.	ALL	350		ALL	275	
	PFA	ALL	350		ALL	250	
	ETFE	ALL	300				
	PVDF	ALL	275				
	Neoprene & Hard Rubber	ALL	200		ALL	200	
	POLYPROP	ALL	150				
	PVC	ALL	140				
PROPANE GAS C ₃ H ₈						See "Gas, Propane"	
PROPIONIC ACID CH ₃ CH ₂ CO ₂ H						See "Acetic Acid"	
PROPYLENE GLYCOL C ₃ H ₈ O ₂	C.I.	ALL	350	PTFE EPDM Butyl Nitrile	ALL	350	*Use Glass lined DI above 325° F
	ST. STL.	ALL	350		ALL	275	
	GLASS	ALL	350*		ALL	225	
	PFA	ALL	275				
	ETFE	ALL	275		ALL	180	
	POLYPROP	ALL	200				
	PVC	ALL	140				
PVDF	ALL	150					
PROTEINS	BRONZE	ALL	350	PTFE EPDM Butyl White Butyl	ALL	350	Check carrier *Use Glass lined DI above 325° F
	ST. STL.	ALL	350		ALL	275	
	GLASS	ALL	350*		ALL	250	
	PFA	ALL	275		ALL	225	
	ETFE	ALL	275				
	PVDF	ALL	200				

Service Guide

SERVICE	BODY			DIAPHRAGM			REMARKS
	MATERIAL	MAXIMUM		MATERIAL	MAXIMUM		
		CONC BY WT	TEMP °F		CONC BY WT	TEMP °F	
PYRIDINE C ₅ H ₅ N	C. I. ST. STL. GLASS PFA ETFE POLYPROP	ALL ALL ALL ALL ALL ALL	350 350 350* 240 150 75	PTFE EPDM	ALL ALL	350 150	Use CI if contamination is no problem. *Use Glass lined DI above 325° F
QUATENARY AMMONIUM COMPOUNDS	ST. STL. GLASS PFA ETFE Hard Rubber PVC	ALL ALL ALL ALL ALL ALL	350 350* 275 275 200 140	PTFE EPDM	ALL ALL	350 275	*Use Glass lined DI above 325° F
RADIOACTIVE MATERIALS	ST. STL. GLASS PFA ETFE PVDF	ALL ALL * * *	300 300 350 300 285	EPDM**	*	300	*Depends on radiation exposure expressed in Rads or Roentgens per hour; Contact factory **Do not use if hydrocarbons are present
RAG STOCK	ST. STL. PFA ETFE Hard Rubber PVC	ALL ALL ALL ALL ALL	350 350 300 200 140	PTFE EPDM Neoprene	ALL ALL ALL	350 225 200	Recommendations based on no free chlorine.
RAYON SPIN BATH	GLASS PFA ETFE Hard Rubber	ALL ALL ALL ALL	350* 250 250 200	PTFE	ALL	350	Usually contains carbon bisulfide and hydrogen sulfide *Use Glass lined DI above 325° F
RIVER WATER RUM							See "Water, River"
	BRONZE ST. STL. PVDF	ALL ALL ALL	350 350 225	PTFE Butyl White Butyl	ALL ALL ALL	350 250 225	
SALAD DRESSING	BRONZE ST. STL. PFA ETFE PVDF PVC	ALL ALL ALL ALL ALL ALL	350 350 350 300 285 140	PTFE Nitrile	ALL ALL	350 180	Use travel stops with elastomer diaphragms
SALT BRINE	PFA ETFE PVDF Hard Rubber Soft Rubber POLYPROP PVC	ALL ALL ALL ALL ALL ALL ALL	350 300 285 200 150 150 140	PTFE EPDM Butyl Nitrile	ALL ALL ALL ALL	350 250 225 180	Recommendations based on no free chlorine
SALT BRINE, CHLORINATED	GLASS PFA ETFE PVDF	ALL ALL ALL ALL	350* 350 300 285	PTFE EPDM	ALL ALL	350 125	*Use Glass lined DI above 325° F
SAND	Neoprene Soft Rubber	ALL ALL	200 150	Neoprene Nitrile Natural Rubber	ALL ALL ALL	150 150 150	Neoprene or Nitrile where oils are present

Service Guide

SERVICE	BODY			DIAPHRAGM			REMARKS
	MATERIAL	MAXIMUM		MATERIAL	MAXIMUM		
		CONC BY WT	TEMP °F		CONC BY WT	TEMP °F	
SEA WATER	MONEL	ALL	350	PTFE	ALL	350	Cl, DI will rust and pit
	GLASS	ALL	350	EPDM	ALL	300	
	BRONZE	ALL	350	Natural Rubber	ALL	180	
	POLYPROP	ALL	180				
	Hard Rubber	ALL	180				
	PVDF	ALL	285				
SEWAGE	C.I.	ALL	350	PTFE	ALL	350	If sewage contains fats or oils, use Nitrile or Neoprene with travel stops; Glass can be used to prevent accumulation of scum and grease
	PFA	ALL	350	EPDM	ALL	275	
	ETFE	ALL	300	Neoprene	ALL	200	
	Neoprene, Soft Rubber	ALL	150	Nitrile	ALL	180	
	PVC	ALL	140				
	GLASS	ALL	200				
	PVDF	ALL	250				
SHELLAC (ALCOHOL SOLUTION)	ANY METAL	ALL	350	PTFE	ALL	350	If valve is allowed to dry out, use PTFE *Use Glass lined DI above 325° F
	GLASS	ALL	350*	EPDM	ALL	275	
SILICA SLURRY SiO ₂	Soft Rubber	ALL	150	EPDM	ALL	150	
				Natural Rubber	ALL	150	
SILICON TETRACHLORIDE Si Cl ₄	GLASS	ALL	350*	PTFE	ALL	350	*Use Glass lined DI above 325° F
	PFA	ALL	250				
	ETFE	ALL	250				
	MONEL	ALL	200				
	PVDF	ALL	125				
SILVER CHLORIDE Ag Cl	GLASS	ALL	350*	PTFE	ALL	350	If hydrochloric acid solution, check hydrochloric acid recommendations *Use Glass lined DI above 325° F
	PFA	ALL	350	EPDM	ALL	250	
	ETFE	ALL	300	Butyl	ALL	225	
	PVDF	ALL	285	Neoprene	ALL	200	
	Hard Rubber	ALL	200				
	PVC	ALL	140				
SILVER CYANIDE Ag CN	GLASS	ALL	350*	PTFE	ALL	350	If nitric acid solution, check nitric acid recommendations *Use Glass lined DI above 325° F
	PFA	ALL	350	EPDM	ALL	250	
	ETFE	ALL	300	Butyl	ALL	225	
	PVDF	ALL	285	Neoprene	ALL	200	
	POLYPROP	ALL	200				
	Hard Rubber	ALL	200				
	PVC	ALL	140				
SILVER IODIDE Ag I	GLASS	ALL	350*	PTFE	ALL	350	Check Solvent for elastomer diaphragm recommendation *Use Glass lined DI above 325° F
	PFA	ALL	275	EPDM	ALL	250	
	ETFE	ALL	275	Butyl	ALL	225	
	PVDF	ALL	250	Neoprene	ALL	200	
	Hard Rubber	ALL	150				
	PVC	ALL	140				
SILVER NITRATE Ag NO ₃	GLASS	ALL	350*	PTFE	ALL	350	*Use Glass lined DI above 325° F
	ST. STL.	ALL	350	EPDM	ALL	275	
	POLYPROP	ALL	250	Butyl	ALL	250	
	PVC	ALL	140				
	PVDF	ALL	285				
SIZE	ST. STL.	ALL	350	PTFE	ALL	350	Check carrier *Use Glass lined DI above 325° F
	GLASS	ALL	350*	EPDM	ALL	275	
	PFA	ALL	350	Butyl	ALL	225	
	ETFE	ALL	300	Nitrile	ALL	180	
	PVC	ALL	140	Neoprene	ALL	180	

Service Guide

SERVICE	BODY			DIAPHRAGM			REMARKS
	MATERIAL	MAXIMUM		MATERIAL	MAXIMUM		
		CONC BY WT	TEMP °F		CONC BY WT	TEMP °F	
SLUDGE, ACID	GLASS	ALL	350*	PTFE	ALL	350	If acid is known, check acid recommendations *Use Glass lined DI above 325° F
	PFA	ALL	275	EPDM	ALL	250	
	ETFE	ALL	275				
	PVDF	ALL	250				
	Hard Rubber	ALL	200				
	POLYPROP	ALL	200				
SOAP SOLUTION	C. I.	ALL	350	PTFE	ALL	350	
	PFA	ALL	275	EPDM	ALL	250	
	ETFE	ALL	275				
	Hard Rubber	ALL	200	Nitrile	ALL	180	
	CPVC	ALL	190				
	POLYPROP	ALL	150				
	PVC	ALL	140				
SODA ASH						See "Sodium Carbonate"	
SODIUM ACETATE Na C ₂ H ₃ O ₂	C.I.	ALL	350	PTFE	ALL	350	*Use Glass lined DI above 325° F
	GLASS	ALL	350*	EPDM	ALL	250	
	PFA	ALL	350				
	ETFE	ALL	300	Butyl	ALL	225	
	PVDF	ALL	285	Neoprene	ALL	200	
	Hard Rubber	ALL	180				
	POLYPROP	ALL	175				
	PVC	ALL	140				
SODIUM BENZENE-SULFONATE Na C ₆ H ₅ SO ₃	ST. STL.	ALL	350	PTFE	ALL	350	*Use Glass lined DI above 325° F
	GLASS	ALL	350*				
	PFA	ALL	275				
	ETFE	ALL	275				
	PVDF	ALL	225				
SODIUM BICHROMATE Na ₂ Cr ₂ O ₇ • 2 H ₂ O	ST. STL.	ALL	300	PTFE	ALL	300	
	GLASS	ALL	300	EPDM	ALL	250	
	PFA	ALL	350	Butyl	ALL	225	
	ETFE	ALL	300				
	PVDF	ALL	275				
	POLYPROP	ALL	200				
SODIUM BISULFITE Na H SO ₃	GLASS	ALL	350*	PTFE	ALL	350	*Use Glass lined DI above 325° F
	ST. STL.	ALL	350	EPDM	ALL	250	
	PFA	ALL	350	Butyl	ALL	225	
	ETFE	ALL	300				
	PVDF	ALL	285				
	POLYPROP	ALL	200				
	Hard Rubber	ALL	180				
	PVC	ALL	140				
SODIUM CARBONATE Na ₂ CO ₃	C.I.	ALL	350	PTFE	ALL	350	
	ST. STL.	ALL	350	EPDM	ALL	250	
	POLYPROP	ALL	200				
	Hard Rubber	ALL	180				
	PVDF	ALL	285				
SODIUM CHROMATE Na ₂ CrO ₄ • 4 H ₂ O	ST. STL.	ALL	350	PTFE	ALL	350	*Use Glass lined DI above 325° F
	GLASS	ALL	350*	EPDM	ALL	250	
	PFA	ALL	350	Butyl	ALL	225	
	ETFE	ALL	300				
	PVDF	ALL	200				
	POLYPROP	ALL	150				
	PVC	ALL	140				

Service Guide

SERVICE	BODY			DIAPHRAGM			REMARKS
	MATERIAL	MAXIMUM		MATERIAL	MAXIMUM		
		CONC BY WT	TEMP °F		CONC BY WT	TEMP °F	
SODIUM CHLORATE NaClO ₃	ST. STL.	ALL	300	PTFE	ALL	300	
	GLASS	ALL	300				
	PFA	ALL	250				
	ETFE	ALL	250				
	PVDF	ALL	250				
SODIUM CYANIDE NaCN	ST. STL.	ALL	350	PTFE EPDM Butyl Nitrile	ALL ALL ALL ALL	350 300 250 180	*Use Glass lined DI above 325° F
	C. I.	ALL	350				
	GLASS	ALL	350*				
	PFA	ALL	350				
	ETFE	ALL	300				
	PVDF	ALL	275				
	POLYPROP	ALL	200				
SODIUM GLUTAMATE C ₅ H ₆ (NH ₂)O ₄ Na	ST. STL.	ALL	350	PTFE EPDM Butyl	ALL ALL ALL	350 250 225	*Use Glass lined DI above 325° F
	GLASS	ALL	350*				
	PFA	ALL	350				
	ETFE	ALL	300				
	PVDF	ALL	275				
	PVC	ALL	140				
	SODIUM HYDROXIDE Na OH	PFA	50				
ETFE		50	250				
C. I.*		50	200				
PVDF*		10	125	Neoprene	50	160	
ST. STL.*		50	180				
Hard Rubber		50	180				
Neoprene		50	180				
POLYPROP		50	175				
PVC		ALL	140				
SODIUM HYPOCHLORITE Na OCl		GLASS	ALL				350*
	PFA	ALL	350				
	ETFE	ALL	300				
	PVDF	ALL	150				
	Hard Rubber	ALL	200				
	CPVC	ALL	185				
	PVC	ALL	75				
SODIUM LIGNOSULFONATE	GLASS	ALL	350*	PTFE EPDM Butyl	ALL ALL ALL	350 250 225	*Use Glass lined DI above 325° F
	PFA	ALL	350				
	ETFE	ALL	300				
	PVDF	17%	200				
	Hard Rubber	ALL	200				
	PVC	ALL	140				
	SODIUM METASILICATE Na ₂ Si O ₃	C. I.	ALL				
ST. STL.		ALL	350				
PFA		ALL	350				
ETFE		ALL	300				
PVDF		ALL	275				
PVC		ALL	140				
SODIUM PERBORATE NaBO ₂ • H ₂ O ₂ • 3 H ₂ O		ST. STL.	ALL	175	PTFE EPDM Butyl	ALL ALL ALL	175 175 175
	PFA	ALL	175				
	ETFE	ALL	175				
	PVDF	ALL	175				
	GLASS	ALL	175				
	PVC	ALL	140				

Service Guide

SERVICE	BODY			DIAPHRAGM			REMARKS
	MATERIAL	MAXIMUM		MATERIAL	MAXIMUM		
		CONC BY WT	TEMP °F		CONC BY WT	TEMP °F	
SODIUM PERCHLORATE NaClO ₄ • H ₂ O	ST. STL. PFA ETFE PVDF GLASS PVC	ALL ALL ALL ALL ALL ALL	125 125 125 125 125 125	PTFE	ALL	125	Sodium perchlorate is unstable above 125° F
SODIUM PEROXIDE Na ₂ O ₂	ST. STL. PFA ETFE PVDF GLASS PVC	ALL ALL ALL ALL ALL ALL	125 125 125 125 125 125	PTFE EPDM	ALL ALL	125 125	Sodium peroxide is unstable above 125° F
SODIUM PERSULFATE Na ₂ S ₂ O ₈	ST. STL. PFA ETFE PVDF GLASS PVC	ALL ALL ALL ALL ALL ALL	150 150 150 150 150 140	PTFE EPDM Butyl	ALL ALL ALL	150 150 150	Sodium persulfate is unstable above 150° F
SODIUM SALTS OTHER THAN THOSE LISTED HERE	C. I. GLASS PFA ETFE PVDF CPVC Hard Rubber POLYPROP PVC	ALL ALL ALL ALL ALL ALL ALL ALL ALL	350 350* 350 300 285 190 180 175 140	PTFE EPDM Butyl Neoprene	ALL ALL ALL ALL	350 275 250 200	*Use Glass lined DI above 325° F
SODIUM SILICOFLUORIDE Na ₂ SiF ₆	ST. STL. PFA ETFE PVDF Hard Rubber PVC	ALL ALL ALL ALL ALL ALL	350 350 300 275 200 140	PTFE EPDM Neoprene	ALL ALL ALL	350 250 200	
SODIUM STEARATE C ₁₇ H ₃₅ COONa	ANY METAL GLASS PFA ETFE PVDF POLYPROP	ALL ALL ALL ALL ALL ALL	350 350* 350 300 280 200	PTFE EPDM Butyl Nitrile	ALL ALL ALL ALL	350 300 250 180	*Use Glass lined DI above 325° F
SODIUM SULFATE (GLAUBER'S SALT) Na ₂ SO ₄							See "Sodium Salts"
SODIUM SULFIDE Na ₂ S	C. I. ST. STL. GLASS PFA ETFE PVDF POLYPROP	ALL ALL ALL ALL ALL ALL ALL	350 350 350* 350 300 280 200	PTFE EPDM Butyl	ALL ALL ALL	350 300 250	*Use Glass lined DI above 325° F

Service Guide

SERVICE	BODY			DIAPHRAGM			REMARKS
	MATERIAL	MAXIMUM		MATERIAL	MAXIMUM		
		CONC BY WT	TEMP °F		CONC BY WT	TEMP °F	
SODIUM SULFITE Na ₂ SO ₃	ST. STL.	ALL	350	PTFE	ALL	350	
	C. I.	ALL	350	EPDM	ALL	250	
	PFA	ALL	350	Butyl	ALL	225	
	ETFE	ALL	300	Neoprene	ALL	200	
	PVDF	ALL	275				
	Hard Rubber	ALL	200				
	POLYPROP	ALL	150				
PVC	ALL	140					
SODIUM THIOSULFATE Na ₂ S ₂ O ₃ • 5H ₂ O M.P.118°F.	ANY METAL	ALL	350	PTFE	ALL	350	*Use Glass lined DI above 325° F
	GLASS	ALL	350*	EPDM	ALL	300	
	PFA	ALL	350	Butyl	ALL	250	
	ETFE	ALL	300	Neoprene	ALL	200	
	PVDF	ALL	275	White Butyl	ALL	200	
	POLYPROP	ALL	200				
	PVC	ALL	150				
SOFT DRINKS	BRONZE	ALL	350	PTFE	ALL	350	
	ST. STL.	ALL	350	EPDM (FDA)	ALL	250	
	PVDF	ALL	285	Butyl	ALL	250	
	PVC	ALL	140	White Butyl	ALL	225	
SORBIC ACID C ₆ H ₈ O ₂	ST. STL.	ALL	350	PTFE	ALL	350	Check solvent for correct elastomer diaphragm *Use Glass lined DI above 325° F
	GLASS	ALL	350*	EPDM	ALL	225	
	PFA	ALL	350	Butyl	ALL	225	
	ETFE	ALL	300	Neoprene	ALL	200	
	PVC	ALL	140				
SOUP	ST. STL.	ALL	350	PTFE	ALL	350	*Use Glass lined DI above 325° F
	GLASS	ALL	350*	EPDM (FDA)	ALL	250	
	PVDF	ALL	285	Butyl	ALL	250	
				White Butyl	ALL	175	
SOY BEAN OIL						See "Oil, Soybean"	
SPIRITS (ALCOHOLIC BEVERAGES)	BRONZE	ALL	350	PTFE	ALL	350	
	ST. STL.	ALL	350	Butyl	ALL	250	
	PFA	ALL	350	White Butyl	ALL	225	
	ETFE	ALL	300				
	PVC	ALL	140				
	PVDF	ALL	200				
STANNIC CHLORIDE Sn Cl ₄	GLASS	ALL	350*	PTFE	ALL	350	Decomposes in hot water *Use Glass lined DI above 325° F
	PFA	ALL	350	EPDM	ALL	200	
	ETFE	ALL	300				
	PVDF	ALL	285				
	Hard Rubber	ALL	200				
	PVC	ALL	140				
	POLYPROP	ALL	175				
STANNOUS FLUORIDE Sn F ₂	ST. STL.	ALL	350	PTFE	ALL	350	
	PFA	ALL	212	EPDM	ALL	150	
	ETFE	ALL	212	Butyl	ALL	150	
	Hard Rubber	ALL	200				
	PVC	ALL	140				

Service Guide

SERVICE	BODY			DIAPHRAGM			REMARKS
	MATERIAL	MAXIMUM		MATERIAL	MAXIMUM		
		CONC BY WT	TEMP °F		CONC BY WT	TEMP °F	
STARCH SOLUTIONS (C ₆ H ₁₀ O ₅) _x	ANY METAL	ALL	350	PTFE	ALL	350	Cl will rust Usually a hot service *Use glass lined DI above 325° F
	GLASS	ALL	350*	EPDM	ALL	275	
	PFA	ALL	350	Butyl	ALL	250	
	ETFE	ALL	300	Neoprene	ALL	200	
	Hard Rubber	ALL	200				
	POLYPROP	ALL	200				
	PVDF	ALL	200				
STEAM STERILIZATION				*		Consult factory	
				*			
				*			
				*			
STEARIC ACID CH ₃ (CH ₂) ₁₆ CO ₂ H	ST. STL.	ALL	350	PTFE	ALL	350	If in solution, check solvent *Use Glass lined DI above 325° F
	GLASS	ALL	350*	Nitrile	ALL	180	
	PFA	ALL	350				
	ETFE	ALL	300				
	PVDF	ALL	285				
	CPVC	ALL	190				
	PVC	ALL	140				
	POLYPROP	ALL	150				
STYRENE C ₆ H ₅ CHCH ₂	C. I.	ALL	350	PTFE	ALL	350	
	BRONZE	ALL	350				
	ST. STL.	ALL	350				
	PVDF	ALL	180				
SUGAR SLURRY	C. I.	ALL	250	Butyl	ALL	200	Use of CI or Stainless Steel depends on velocity, as service is abrasive
	ST. STL.	ALL	250	Natural Rubber	ALL	160	
	Soft Rubber	ALL	150				
SUGAR SOLUTION	C.I.	ALL	350	PTFE	ALL	350	*Use Glass lined DI above 325° F
	BRONZE	ALL	350	EPDM (FDA)	ALL	200	
	ST. STL.	ALL	350	Butyl	ALL	200	
	GLASS	ALL	350*	EPDM	ALL	200	
	PFA	ALL	350	White Butyl	ALL	180	
	ETFE	ALL	300				
	PVDF	ALL	285				
SULFAMIC ACID HSO ₃ NH ₂	GLASS	30	350*	PTFE	30	350	*Use Glass lined DI above 325° F
	PFA	30	250	EPDM	30	225	
	ETFE	30	250	Butyl	30	212	
	POLYPROP	30	200				
	Hard Rubber	30	200				
	PVC	30	140				
SULFATE LIQUOR	ST. STL.	ALL	350	PTFE	ALL	350	
	PFA	ALL	350	EPDM	ALL	250	
	ETFE	ALL	300	Butyl	ALL	225	
	Hard Rubber	ALL	200				
	POLYPROP	ALL	175				
	PVC	ALL	140				
SULFONATED DETERGENTS	C. I.	ALL	350	PTFE	ALL	350	
	BRONZE	ALL	350	EPDM	Dilute	275	
	ST. STL.	ALL	350	Nitrile	ALL	180	
	PFA	ALL	275				
	ETFE	ALL	275				
	PVC	ALL	140				

Service Guide

SERVICE	BODY			DIAPHRAGM			REMARKS
	MATERIAL	MAXIMUM		MATERIAL	MAXIMUM		
		CONC BY WT	TEMP °F		CONC BY WT	TEMP °F	
SULFUR DIOXIDE GAS (WET) SO ₂	GLASS	ALL	350*	PTFE	ALL	350	*Use Glass lined DI above 325° F
	ST. STL.	ALL	350				
	PFA	ALL	250				
	ETFE	ALL	250				
	PVDF	ALL	175				
	Hard Rubber	ALL	180				
	CPVC	ALL	140				
SULFUR DIOXIDE SOLUTION SO ₂ + H ₂ O	GLASS	ALL	350*	PTFE EPDM Butyl	ALL ALL ALL	350 100 100	*Use Glass lined DI above 325° F
	ST. STL.	ALL	350				
	PFA	ALL	250				
	ETFE	ALL	250				
	PVDF	ALL	200				
	Hard Rubber	ALL	180				
	CPVC	ALL	140				
SULFUR SLURRY	C. I.	ALL	350	EPDM Butyl 	ALL ALL	250 225	Molten sulfur, consult factory
	D. I.	ALL	350				
	ST. STL.	ALL	350				
SULFURIC ACID H ₂ SO ₄	GLASS	ALL	325*††	PTFE Viton Butyl EPDM	ALL 95 60 25	350 158 150 150	66° Baume is 93% *Use Glass lined DI above 325° F Δ Polyprop can be used at higher temperatures at lower concentrations. ††If concentration 50% or more, maximum temperature 350° F
	PFA	ALL	350				
	ETFE	ALL	300				
	PVDF	93	200				
	CN7M	ALL	175				
	Hard Rubber	50	170				
	POLYPROPΔ	80	100				
	CPVC	93	73				
	PVC	93	73				
SULFURIC ACID FUMING (OLEUM) H ₂ SO ₄ + SO ₃	GLASS	ALL	325	PTFE Viton	ALL 20	325 130	Sometimes expressed as sulfuric acid over 100%.
	CN7M	ALL	150				
	PFA	ALL	150				
	ETFE	ALL	150				
SULFUROUS ACID H ₂ SO ₃	GLASS	ALL	325	PTFE Butyl	ALL 50	325 150	Do not use soft rubber or neoprene
	PFA	ALL	230				
	ETFE	ALL	230				
	CN7M	ALL	200				
	ST. STL.	ALL	150				
	PVDF	ALL	200				
	POLYPROP	ALL	150				
SYNTHETIC DETERGENTS	C. I.	ALL	350	PTFE EPDM Nitrile	ALL Dilute ALL	350 250 180	
	BRONZE	ALL	350				
	ST. STL.	ALL	350				
	PFA	ALL	250				
	ETFE	ALL	250				
	PVC	ALL	140				
SYRUP	BRONZE	ALL	350	PTFE Butyl White Butyl	ALL ALL ALL	350 250 225	*Use Glass lined DI above 325° F
	ST. STL.	ALL	350				
	GLASS	ALL	350*				
	PFA	ALL	350				
	ETFE	ALL	300				
	PVC	ALL	140				
	PVDF	ALL	275				
TALC SLURRY Mg ₃ S ₁₄ O ₁₀ (OH) ₂	GLASS	ALL	350*	PTFE EPDM	ALL ALL	350 275	*Use Glass lined DI above 325° F
	Soft Rubber	ALL	150				

Service Guide

SERVICE	BODY			DIAPHRAGM			REMARKS
	MATERIAL	MAXIMUM		MATERIAL	MAXIMUM		
		CONC BY WT	TEMP °F		CONC BY WT	TEMP °F	
TALLOW	C.I.	ALL	350	PTFE	ALL	350	Use travel stops with elastomer diaphragms
	BRONZE	ALL	350	Viton	ALL	200	
	PFA	ALL	350	Nitrile	ALL	150	
	ETFE	ALL	300				
	PVDF	ALL	285				
TANNIC ACID C ₁₄ H ₁₀ O ₉	ST. STL.	ALL	350	PTFE	ALL	350	Check solvent for elastomer diaphragm recommendation *Use Glass lined DI above 325° F
	GLASS	ALL	350*	EPDM	ALL	275	
	PFA	ALL	275	Nitrile	ALL	180	
	ETFE	ALL	275				
	PVDF	ALL	225				
	CPVC	ALL	190				
	POLYPROP	ALL	150				
PVC	ALL	140					
TARTARIC ACID [CH(OH)COOH] ₂	ST. STL.	ALL	350	PTFE	ALL	350	*Use Glass lined DI above 325° F
	GLASS	ALL	350*	EPDM	ALL	225	
	PFA	ALL	275	Butyl	ALL	200	
	ETFE	ALL	275	Hypalon	ALL	200	
	PVDF	ALL	250	Nitrile	ALL	180	
	Hard Rubber	ALL	200				
	POLYPROP	ALL	150				
	PVC	ALL	140				
TEXTILE DYES	GLASS	ALL	350*	PTFE	ALL	350	Check carrier *Use Glass lined DI above 325° F
	ST. STL.	ALL	350	EPDM	ALL	250	
	PFA	ALL	250	Butyl	ALL	225	
	ETFE	ALL	250				
	PVC	ALL	140				
	Neoprene	ALL	200				
THIOGLYCOLIC ACID HSCH ₂ COOH	ST. STL.	ALL	350	PTFE	ALL	350	*Use Glass lined DI above 325° F
	GLASS	ALL	350*	EPDM	ALL	250	
	PFA	ALL	250	Butyl	ALL	225	
	ETFE	ALL	250				
	PVDF	ALL	175				
PVC	ALL	140					
TIN TETRACHLORIDE Sn Cl ₄							See "Stannic Chloride"
TIN PLATING SOLUTION	GLASS	ALL	350*	PTFE	ALL	350	*Use Glass lined DI above 325° F
	PFA	ALL	250	EPDM	ALL	250	
	ETFE	ALL	250	Butyl	ALL	225	
	Hard Rubber	ALL	200				
	PVC	ALL	140				
	PVDF	ALL	200				
TITANIUM DIOXIDE SLURRY Ti O ₂	PFA	ALL	250	EPDM	ALL	250	Check carrier; ETFE also recommended if high temperature present
	ETFE	ALL	250	Neoprene Natural Rubber	ALL	180	
	Soft Rubber	ALL	150		ALL	150	
	Neoprene	ALL	150				
T. N. T. SLURRY CH ₃ C ₆ H ₂ (NO ₂) ₃ M. P.178° F	ST. STL.	ALL	350	PTFE	ALL	350	ETFE, PFA and PTFE for hot service; Check carrier *Use Glass lined DI above 325° F
	GLASS	ALL	350*	EPDM	ALL	125	
	PFA	ALL	275	Neoprene	ALL	125	
	ETFE	ALL	275	Nitrile	ALL	125	
	D. I.	ALL	125				
	C. I.	ALL	125				
TOLUENE CH ₃ C ₆ H ₅	ANY METAL	ALL	350	PTFE	ALL	350	*Use Glass lined DI above 325° F
	GLASS	ALL	350*	Viton	ALL	100	
	PFA	ALL	250				
	ETFE	ALL	250				
	PVDF	ALL	170				

Service Guide

SERVICE	BODY			DIAPHRAGM			REMARKS
	MATERIAL	MAXIMUM		MATERIAL	MAXIMUM		
		CONC BY WT	TEMP °F		CONC BY WT	TEMP °F	
TOMATO PASTE	ST. STL.	ALL	350	PTFE Nitrile Butyl	ALL	350	*Use Glass lined DI above 325° F
	GLASS	ALL	350*		ALL	180	
	PFA	ALL	275		ALL	100	
	ETFE	ALL	275				
	PVDF	ALL	212				
TOOTH PASTE	BRONZE	ALL	350	PTFE Butyl White Butyl	ALL	350	*Use Glass lined DI above 325° F
	ST. STL.	ALL	350		ALL	250	
	GLASS	ALL	350*		ALL	225	
	PFA	ALL	350				
	ETFE	ALL	300				
	POLYPROP	ALL	200				
	PVDF	ALL	250				
TRICHLORO-ETHYLENE CH ₂ Cl ₂	ANY METAL	ALL	350	PTFE	ALL	350	*Use Glass lined DI above 325° F
	GLASS	ALL	350*				
	PFA	ALL	275				
	ETFE	ALL	275				
	PVDF	ALL	150				
TRIETHANOLAMINE (CH ₂ OHCH ₂) ₃ N	C. I.	ALL	350	PTFE EPDM	ALL	350	*Use Glass lined DI above 325° F
	D. I.	ALL	350				
	GLASS	ALL	350*				
	PFA	ALL	250				
	ETFE	ALL	250				
TRIETHYLENE GLYCOL C ₆ H ₁₄ O ₄	ANY METAL	ALL	350	PTFE EPDM Butyl	ALL	350	
					ALL	250	
					ALL	225	
					ALL	180	
TRINITROTOLUENE TURPENTINE							See "TNT Slurry"
U. D. M. H.* (CH ₃) ₂ NNH ₂	ANY METAL	ALL	350	PTFE Nitrile Viton	ALL	350	*Unsymmetrical dimethylhydrazine **Use Glass lined DI above 325° F
	PFA	ALL	275		ALL	160	
	ETFE	ALL	275			160	
	PVDF	ALL	285				
URANIUM ORES	Neoprene	ALL	200	EPDM	ALL	200	
	Soft Rubber	ALL	150				
URANIUM SALTS				Natural Rubber	ALL	150	ETFE, PFA and PVDF may also be used when plastics are desired *Use Glass lined DI above 325° F
	ST. STL.	ALL	350				
	GLASS	ALL	350*				
	Hard Rubber	ALL	200				
	Neoprene	ALL	200				
Soft Rubber	ALL	150					
UREA CO (NH ₂) ₂	ANY METAL	ALL	350	PTFE EPDM Neoprene Nitrile	ALL	350	
	PFA	ALL	275				
	ETFE	ALL	275				
	PVDF	ALL	200				
	POLYPROP	50	200				
	CPVC	ALL	190				
	PVC	ALL	140				
UREA AMMONIA SOLUTIONS	C. I.	ALL	200	EPDM Neoprene	ALL	200	Cl or DI may corrode
	D. I.	ALL	200				
VACUUM	Weir diaphragm valves are suitable for vacuum service down to 0.1 micron. For higher vacuum consult factory. Specify "VACUUM" when ordering.						

Service Guide

SERVICE	BODY			DIAPHRAGM			REMARKS
	MATERIAL	MAXIMUM		MATERIAL	MAXIMUM		
		CONC BY WT	TEMP °F		CONC BY WT	TEMP °F	
VARNISH	GLASS PVDF	ALL ALL	350* 250	PTFE	ALL	350	Any smooth metal body is satisfactory if pipeline is not allowed to dry out *Use Glass lined DI above 325° F
VASELINE	BRONZE ST. STL. GLASS PVDF	ALL ALL ALL ALL	350 350 350* 285	PTFE Nitrile	ALL ALL	350 180	Use travel stops with elastomer diaphragms *Use Glass lined DI above 325° F
VEGETABLE OILS							See "Oil, Vegetable"
VINEGAR	ST. STL. GLASS PFA ETFE CPVC POLYPROP PVC PVDF	ALL ALL ALL ALL ALL ALL ALL ALL	350 350* 275 275 190 175 140 225	PTFE EPDM (FDA) EPDM Butyl	ALL ALL ALL ALL	350 200 200 150	*Use Glass lined DI above 325° F
VINYL CHLORIDE MONOMER CH ₂ CHCl	ST. STL. GLASS PFA ETFE PVDF	ALL ALL ALL ALL ALL	350 350* 225 225 200	PTFE	ALL	350	*Use Glass lined DI above 325° F
VINYL LATEX	GLASS PFA ETFE PVDF	ALL ALL ALL ALL	350* 250 250 200	PTFE	ALL	350	Glass and PTFE best choice because of sticking when lines dry out *Use Glass lined DI above 325° F
WATER, ACID	PFA ETFE PVDF POLYPROP Hard Rubber Neoprene PVC	ALL ALL ALL ALL ALL ALL ALL	350 300 275 200 200 200 140	PTFE EPDM Butyl Nitrile	ALL ALL ALL ALL	300 275 200 180	Check type of acid and concentration
WATER, ALKALINE	PFA ETFE PVDF POLYPROP Hard Rubber Neoprene PVC	ALL ALL ALL ALL ALL ALL ALL	350 300 250 200 200 200 140	PTFE EPDM Nitrile	ALL ALL ALL	300 275 180	Cl if high alkaline
WATER, DEIONIZED	ST. STL. PFA ETFE POLYPROP PVC PVDF	ALL ALL ALL ALL ALL ALL	300 350 300 200 150 250	PTFE EPDM (FDA) EPDM Butyl Natural Rubber	ALL ALL ALL ALL ALL	300 300 300 250 180	
WATER, DISTILLED	ST. STL. PFA ETFE POLYPROP PVC PVDF	ALL ALL ALL ALL ALL ALL	350 350 300 200 140 285	PTFE EPDM (FDA) EPDM Butyl	ALL ALL ALL ALL	350 275 275 250	Check amount of impurities allowed
WATER, GENERAL	C. I. BRONZE PFA ETFE PVDF POLYPROP PVC	ALL ALL ALL ALL ALL ALL ALL	350 350 350 300 285 200 140	PTFE EPDM (FDA) EPDM Butyl Nitrile	ALL ALL ALL ALL ALL	350 250 250 225 180	

Service Guide

SERVICE	BODY			DIAPHRAGM			REMARKS
	MATERIAL	MAXIMUM		MATERIAL	MAXIMUM		
		CONC BY WT	TEMP °F		CONC BY WT	TEMP °F	
WATER, HEAVY D ₂ O	ST. STL.	ALL	350	PTFE	ALL	350	Elastomer diaphragms may contaminate; EPDM possible, let user decide *Use Glass lined DI above 325° F
	GLASS	ALL	350*	EPDM	ALL	300	
	PVDF	ALL	225				
WATER, RIVER	C.I.	ALL	350	PTFE	ALL	350	*If laden with silt or sand, use Soft Rubber
	D.I.	ALL	350	EPDM	ALL	275	
	PFA	ALL	350	Butyl	ALL	250	
	ETFE	ALL	300	Nitrile	ALL	180	
	PVDF	ALL	285				
	Hard Rubber*	ALL	200				
PVC	ALL	140					
WATER, SEA							See "Sea Water"
WAX	ANY METAL	ALL	350	PTFE	ALL	350	Use travel stops with elastomer diaphragms *Use Glass lined DI above 325° F
	GLASS	ALL	350*	Nitrile	ALL	180	
WHISKEY	BRONZE	ALL	350	PTFE	ALL	350	*Use Glass lined DI above 325° F
	ST. STL.	ALL	350	Butyl	ALL	250	
	GLASS	ALL	350*	White Butyl	ALL	225	
	CPVC	ALL	190				
	PVDF	ALL	200				
WHITE WATER (SULFATE LIQUOR)	C. I.	ALL	350	PTFE	ALL	350	
	ST. STL.	ALL	350	EPDM	ALL	275	
	PFA	ALL	275	Butyl	ALL	200	
	ETFE	ALL	275				
	Hard Rubber	ALL	200				
WORT	BRONZE	ALL	350	PTFE	ALL	350	
	ST. STL.	ALL	350	Butyl	ALL	250	
				White Butyl	ALL	225	
XYLENE C ₈ H ₁₀	ANY METAL	ALL	350	PTFE	ALL	350	*Use Glass lined DI above 325° F
	GLASS	ALL	350*	Viton	ALL	100	
	PFA	ALL	230				
	ETFE	ALL	230				
	PVDF	ALL	175				
YEAST	BRONZE	ALL	350	PTFE	ALL	350	*Use Glass lined DI above 325° F
	ST. STL.	ALL	350	Butyl	ALL	250	
	GLASS	ALL	350*	White Butyl	ALL	200	
	PFA	ALL	350				
	ETFE	ALL	300				
ZINC ACETATE Zn (C ₂ H ₃ O ₂) ₂ • 2H ₂ O	ST. STL.	ALL	350	PTFE	ALL	350	*Use Glass lined DI above 325° F
	GLASS	ALL	350*	EPDM	ALL	200	
	PFA	ALL	350	Butyl	ALL	200	
	ETFE	ALL	300				
	Hard Rubber	ALL	200				
	Chlorobutyl	ALL	180				
	PVC	ALL	140				
	PVDF	ALL	250				
ZINC CHLORIDE Zn Cl ₂	ST. STL.	ALL	350	PTFE	ALL	350	Check carrier *Use Glass lined DI above 325° F
	GLASS	ALL	350*	EPDM	ALL	200	
	PFA	ALL	350	Butyl	ALL	200	
	ETFE	ALL	300	Neoprene	ALL	150	
	PVDF	ALL	285				
	Hard Rubber	ALL	200				
	Chlorobutyl	ALL	180				
	PVC	ALL	140				

Service Guide

SERVICE	BODY			DIAPHRAGM			REMARKS
	MATERIAL	MAXIMUM		MATERIAL	MAXIMUM		
		CONC BY WT	TEMP °F		CONC BY WT	TEMP °F	
ZINC OXIDE Zn O	PFA	ALL	250	EPDM	ALL	250	Slurry
	ETFE	ALL	250	Natural Rubber	ALL	180	
	Soft Rubber	ALL	150				
	PVDF	ALL	250				
ZINC PLATING SOLUTION	PFA	ALL	350	PTFE	ALL	300	
	ETFE	ALL	300	EPDM	ALL	180	
	PVDF	ALL	210	Butyl	ALL	180	
	Hard Rubber	ALL	200				
	Chlorobutyl	ALL	180				
	PVC	ALL	140				
ZINC SULFIDE Zn S	ST. STL.	ALL	350	PTFE	ALL	350	*Use Glass lined DI above 325° F
	GLASS	ALL	350*	EPDM	ALL	275	
	PFA	ALL	350	Butyl	ALL	250	
	ETFE	ALL	300				
	PVDF	ALL	285				
	Hard Rubber	ALL	200				
	Chlorobutyl	ALL	180				
ZINC SULFATE Zn SO ₄ • 7H ₂ O	ST. STL.	ALL	350	PTFE	ALL	350	*Use Glass lined DI above 325° F
	GLASS	ALL	350*	EPDM	ALL	250	
	PFA	ALL	350	Butyl	ALL	225	
	ETFE	ALL	300				
	PVDF	ALL	285	Neoprene	ALL	200	
	Hard Rubber	ALL	200				
	POLYPROP	ALL	200				
	CPVC	ALL	190				
	Chlorobutyl	ALL	180				
	PVC	ALL	140				

Section 6

Other Information



Contained in this section:

- How To Order
- Maintenance Instructions
- Flange Gasket and Storage Recommendations
- Actuator Diaphragm Identification
- Facts and Recommended Guidelines
- Terms and Conditions

Ordering Information

Dia-Flo Figure Number Block Sequence for Weir Valves

Size	Body	Diaphragm	Bonnet	Optional Bonnet Internals	Optional Coatings		
Block A	Block B	Block D	Block E	Block H	Block N		
Dia-Flo® Actuator	Advantage® Actuator	Position Indicator	Mechanical Accessories	Limit Switches	Positioner	Additional Options	
Block P	Block Q	Block T	Block V	Block Y	Block AA	*	

The above blocks are the most commonly used. For a complete listing see the Other Blocks listed on page 213.

Constructing Figure Numbers

Below are examples for constructing a manual and actuated valve figure number.

Manual Valve Example

Figure Number: 1-2401-TM-903

Detailed Description:

- 1: 1 Inch Size
- 2401: Cast Iron, Screwed End Valve
- TM: Modified PTFE Diaphragm (FDA)
- 903: Cast Iron Handwheel Operated Bonnet Assembly, Indicating with Travel Stop

Actuated Valve Example

Figure Number: 3-2521-T-34-3125

Detailed description:

- 3: 3 Inch Size
- 2521: Cast Iron, Flanged End Valve, Lined with Hard Rubber No. 10
- T: Neoprene Diaphragm
- 34: Ductile Iron Actuated Bonnet
- 3125: #25 Fail Open (Air-to-Close, Spring-to-Open) Actuator

Block A: Size

Code	Description
.50	.50 Inch
.75	.75 Inch
1	1 Inch
1.25	1.25 Inch
1.5	1.5 Inch
2	2 Inch
2.5	2.5 Inch
3	3 Inch
4	4 Inch
6	6 Inch
8	8 Inch
10	10 Inch
12	12 Inch

Ordering Information

Block B: Body

Weir Bodies, Unlined

Code	Body Material	Size
NO BODY SUPPLIED		
2000	No Body (Bonnet Only)	1/2"-12"
SCREWED		
2401	Iron	1/2"-3"
2402	Bronze	1/2"-3"
2403	Stainless Steel (316)	1/2"-2"
2405	Cast Steel	1/2"-2"
2406	Solid PVC	1/2"-2"
2407	CN7M	1/2"-2"
2408	Monel	1/2"-2"
2410	Hastelloy	1/2"-2"
2412	Ductile iron	1"-3"
2416	CPVC	1/2"-2"
2417	PVDF* (FDA)	1/2"-2"

FLANGED

2431	Cast Iron	1/2"-12"
2432	Bronze	1/2"-6"
2433R	Stainless Steel (316)	1/2"-8"
2434R	Stainless Steel (316L)	1/2"-8"
2435R	Cast Steel	1/2"-8"
2436	Solid PVC	1/2"-4"
2437R	CN7M	1/2"-8"
2438R	Monel	1/2"-8"
2440R	Hastelloy	1/2"-8"
2441	Ductile Iron	1/2"-12"
2442	Solid CPVC	1/2"-2"
2447	Solid PVDF* (FDA)	1/2"-4"

SOCKET SOLDER

2456	Bronze	1/2"-2"
------	--------	---------

SOCKETWELD

2427	Solid PVDF* (FDA)	1/2"-2"
2451	Solid PVC	1/2"-2"
2463	Solid CPVC	1/2"-2"
2470	Stainless Steel (316L)	1/2"-3"
2472	Cast Steel	1/2"-3"
2474	CN7M	1/2"-3"

BUTTWELD (316L)

2464	Stainless Steel Sch. 5	1/2"-6"
2465	Stainless Steel Sch. 10	1/2"-6"
2466	Stainless Steel Sch. 40	1/2"-6"

SPIGOT WELD

2443	CPVC (IPS)	1/2"-2"
2486	PVC (IPS)	1/2"-4"
2487	Solid PVDF* (FDA, DIN)	1/2"-4"

Weir Bodies, Lined

Code	Lining Material	Size
FLANGED CAST IRON		
2501	Neoprene No. 7	1/2"-12"
2511	Glass Lined (FDA)	1/2"-8"
2516	Soft Rubber No. 5	1/2"-12"
2521	Hard Rubber No. 10	1/2"-12"
2522	Butyl Lined	1/2"-12"
2536	PVC Lined	3/4"-8"
2538	PP Lined (FDA)	3/4"-8"
2539	PP* Lined (FDA)	3/4"-8"
2529	ETFE Lined	3/4"-8"
2575	PVDF* Lined (FDA)	3/4"-8"

Weir Bodies, Lined (Continued)

Code	Lining Material	Size
FLANGED DUCTILE IRON		
2544	Glass Lined (FDA)	1/2"-10"
2550	Neoprene No. 7	1/2"-8"
2551	Soft Rubber No. 5	1/2"-8"
2552	Hard Rubber No. 10	1/2"-8"
2555	PVDF* Lined (FDA)	3/4"-8"
2556	PFA Lined (FDA)	1"-6"
2558	PP Lined (FDA)	3/4"-8"
2559	ETFE Lined	3/4"-8"
FLANGED CAST STEEL		
2545	ETFE Lined	3/4"-8"
2546	PP Lined (FDA)	3/4"-8"
2548	PVDF* Lined (FDA)	3/4"-8"
2561	Neoprene No. 7	1/2"-8"
2563	Hard Rubber No. 10	1/2"-8"
2564	PFA Lined (FDA)	1/2"-6"

FLANGED STAINLESS STEEL

2540	PFA Lined (FDA)	1/2"-6"
2549	ETFE Lined	3/4"-8"

Block D: Diaphragms Weir Type

Code	Material	Size
B	Black Butyl (FDA)	1/2"-12"
C	Hypalon**	1/2"-12"
M	EPDM	1/2"-12"
E1	EPDM (FDA)	1/2"-8"
P	BUNA - N (FDA)	1/2"-12"
S	Natural Rubber	1/2"-8"
T	Neoprene	1/2"-12"
W1	White Butyl (FDA)	1/2"-6"
DP	Buna N Direct Loaded (FDA)	1/2"-3"
V	Viton	1/2"-6"
TM	Modified PTFE (FDA)	1/2"-6"
R2	PTFE (FDA)	8", 10"
EN	Elastomer Not Supplied	1/2"-12"
PN	PTFE Not Supplied	1/2"-10"

Block E: Bonnet

Bonnets, Handwheel

Code	Bonnet Description	Size
CAST IRON		
902	Indicating	6-12"
902S	Indicating, Sealed	6-12"
903	Indicating w/ Travel Stop	1 1/4"-12"
903S	Indicating w/ Travel Stop, Sealed	1 1/4"-12"

STAINLESS STEEL (316)

912	Indicating	6"
912S	Indicating, Sealed	6"

STAINLESS STEEL (316)

913	Indicating w/ Travel Stop	1/2"-6"
913S	Indicating w/ Travel Stop, Sealed	1/2"-6"

*Unpigmented

**Refer to Factory for Availability

Bonnets, Handwheel (Continued)

Code	Bonnet Description	Size
BRONZE		
932	Indicating	6-12"
932S	Indicating, Sealed	6-12"
933	Indicating w/ Travel Stop	1/2"-4"
933S	Indicating w/ Travel Stop, Sealed	1/2"-4"
DUCTILE IRON		
942	Indicating	6-8"
942S	Indicating - Sealed	6-8"
943	Indicating w/ Travel Stop	1/2"-8"
943S	Indicating w/ Travel Stop, Sealed	1/2"-8"
PLASTIC PAS		
963	Indicating w/ Travel Stop	1/2"-4"
963S	Indicating w/ Travel Stop, Sealed	1/2"-4"

Bonnets, Chainwheel

Code	Bonnet Description	Size
CAST IRON		
905	Indicating w/ Travel Stop	1/2"-12"
905S	Indicating w/ Travel Stop, Sealed	1/2"-12"
STAINLESS STEEL (316)		
915	Indicating w/ Travel Stop	1/2"-6"
915S	Indicating w/ Travel Stop, Sealed	1/2"-6"
BRONZE		
935	Indicating w/ Travel Stop	1/2"-4"
935S	Indicating w/ Travel Stop, Sealed	1/2"-4"
DUCTILE IRON		
945	Indicating w/ Travel Stop	1/2"-6"
945S	Indicating w/ Travel Stop, Sealed	1/2"-6"

Actuated Bonnets

Code	Bonnet Description	Size
STAINLESS STEEL		
31	Actuated	1/2"-6"
31S	Actuated - Sealed	1/2"-6"
BRONZE		
33	Actuated	1/2"-6"
33S	Actuated - Sealed	1/2"-6"
DUCTILE IRON (34 is std - Dia-Flo® Actuator)		
34	Actuated	1/2"-10"
34S	Actuated - Sealed	1/2"-10"
84	Dual Range	1-6"
84S	Dual Range Sealed	1-6"
PLASTIC PAS (36 is std - Advantage® Actuator)		
36	Actuated	1/2"-4"
36S	Actuated - Sealed	1/2"-4"
CAST IRON		
40	Direct Load	1/2"-3"

Ordering Information

Block H: Optional Bonnet Internals

Code	Description
M2	Sanitary Internals
M5	Stainless Steel Stem
M6	Cast Iron Compressor
M7	Bronze Compressor
M8	PVDF Coated Cast Iron Compressor
M9	Stainless Steel Bushing
M10	Stainless Steel Tube Nut
M11	316 Stainless Steel Stem
M14	Clear Cap

Block N: Optional Coating

Code	Description
C1	PVDF Coated Topworks
C2	PVDF Coated Body
C3	PVDF Coated Body & Topworks
C4	White Epoxy Coated Topworks
C5	White Epoxy Coated Body
C6	White Epoxy Coated Body & Topworks
C7	Nylon Coated Topworks (Bonnet for 3" & 4" Advantage® only)

Adapted for But Less ITT Actuation (Block P2)

Code	Description
Y	Adapted for But Less ITT Engineered Valves Air Motor

Block P: Dia-Flo® Actuator Fail Open Actuators (Spring-to-Open, Air-to-Close)

Code	Actuator Size
3112	#12
3125	#25
3150	#50
31101	#101
31130	#130
31250	#250

Fail Closed Actuators (Air-to-Open, Spring-to-Close)

Code	Actuator Size
3212	#12
3225	#25
3250	#50
3275	#75
32101	#101
32130	#130
32250	#250

Code Spring Description

Code	Spring Description
SIZE #12	
3213	88 Spring
3214	88 & 89 Springs
3215	88 & Raymond Springs
3216	89 Spring

SIZE #25

3226	101 Spring
3227	101 & 102A Springs
3228	102A Spring

Fail Closed Actuators (Continued) (Air-to-Open, Spring-to-Close)

Code	Spring Description
SIZE #50	
3251	101 Spring
3252	101 & 102A Springs
3253	97 Spring
3254	96 Spring
3255	96 & 97 Springs
3256	102A Spring

SIZE #75

3274	96 Spring
3276	96 & 97 Springs
3277	97 & 98 Springs
3278	96 & 98 Springs
3279	96, 97 & 98 Springs

SIZE #101

32102	96 Spring
32103	98 Spring
32104	96 & 97 Springs
32105	96 & 98 Springs
32106	97 & 98 Springs
32107	96, 97, & 98 Springs
32108	130 Spring
32109	97 Spring

SIZE #130

32131	97 Spring
32132	96 Spring
32133	98 Spring
32134	96 & 97 Springs
32135	96 & 98 Springs
32136	97 & 98 Springs
32137	96, 97, & 98 Springs
32138	130 Spring

SIZE #250

32251	129 & 130 Springs
32252	129 Spring
32253	130 Spring

Double Acting Actuators (Air-to-Open, Air-to-Close)

Code	Actuator Size
3312	#12
3325	#25
3350	#50
3375	#75
33101	#101
33130	#130
33250	#250

Optional Air Motor Covers (Block P1)

Code	Description
DICVR	Ductile Iron

Block Q: Advantage Actuator Fail Open

Code	Actuator Series
A105	#5
A108	#8
A116	#16
A133	#33
A147	#47

Fail Closed

Code	Actuator Series
A205	#5
A206	#5
A208	#8
A209	#8
A215	#16
A216	#16
A217	#16
A232	#33
A233	#33
A234	#33
A235	#33
A247	#47
A248	#47

Double Acting

Code	Actuator Series
A305	#5
A308	#8
A316	#16
A333	#33
A347	#47

Block T: Position Indicator

Code	Description
P1	Position Indicator

Block V: Mechanical Accessories

Code	Description
AO	Adjustable Opening Stop
ATS	Adjustable Travel Stop
WO	Wrench Opening Device
HWO	Handwheel Opening Device
TOHO	Adjustable Opening Stop and Handwheel Opening Device
TOWO	Adjustable Opening Stop and Wrench Opening Device
HWC	Handwheel Closing Device
TO	Adjustable Opening Stop and Adjustable Travel Stop
THC	Adjustable Opening, Adjustable Travel Stop and Handwheel Closing Device (#25 AM and larger)
TOHC	Adjustable Opening, Adjustable Travel Stop and Handwheel Closing Device (#12 AM only)

Block Y: Limit Switches

Code	Description
LS1	Micro BZE6-2RN
LS2	Micro BAF1-2RN
LS3	Micro DTE6-2RN
LS4	Micro DTF2-2RN
LS5	Micro EX-Q
LS6	Micro EXD-Q-3
LS7	Micro LSA1A
LS8	Westlock 3479 Model 3
LS9	GO 74-13528-A2
LS10	Namco EA700-80100
LS11	Westlock E3479 Model 3
LS12	Namco EA170-34100 / 35100
LS16	Westlock 9881
LS17	Westlock E9881

Ordering Information

Optional Limit Switch Position (Block Y1)

Code	Description
LSO	Limit Switch – Open Only
LSC	Limit Switch – Closed Only

Block AA: Positioner*

Code	Description	Size
PR1 ¹	Conoflow Model 31	¾"-10"
PR2 ²	Conoflow Model 33	¾"-10"
PR3 ¹	Moore 73N12F	½"-6"
PR4 ²	Moore 73 NB	½"-6"
PR5	Moore 73 NFR	½"-6"

Note: Only Codes PR3–PR5 are available for Advantage Actuators

¹ Fail Open & Double Acting Actuators Only

² Fail Closed Actuators Only

⁴ Fail Open Actuators Only

⁵ Direct Acting Actuators Only

Other Blocks

Bonnet Seal Materials (Block F)

Code	Seal Material
S1	EPDM
S2	FKM

Optional Bolting (Block G)

Code	Description
B1	Stainless Steel
B1K	SS Bolt / Kolsterised SS Nut
B316	Stainless Steel (316)
BTFE	XYLAN 1014 Coated B7
B72H	B7 Bolt / 2H Nut
B88	B8 Bolt / 8 Nut
BA20	Alloy 20

Yoke (Block K)

Code	Description
Y	Yoke Supplied

Locking Device (Block L)

Code	Description
LD	Locking Device

Extended Stem (Block M)

Code	Description
EXTSTEM C	Extended Stem (Cap)
EXTSTEM R	Extended Stem (Rim)

Non EV Actuation (Block R & S)

Code	Description
POF	Non-EV Customer Supplied Actuator (Mounted)
POA	Adapted for But Less Customer Supplied Actuator
POM	Non-EV Actuator Supplied and Mounted by Engineered Valves

Actuator Hardware Options (Block U)

Code	Description
HW1	SS Airmotor Bolts
HW2	SS Accessory Brackets
HW3	316 SS Tubing and Fittings
HW4	Plastic Tubing / Brass Fittings
HW5	PVC Coated Tubing / Brass Fittings
HW6	PVC Coated Tubing / SS Fittings

Solenoid Valve (Block W)

Code	Description
SV1	Asco 8320G184, 3-Way
SV2	Asco EF8320G184, 3-Way
SV3	Asco 8345G1, 4-Way
SV4	Asco EF8345G1, 4-Way
SV7	Asco 8320G202, 3-Way
SV8	Asco EF8320G202, 3-Way
SV9	Asco EF8320G45, 3-Way
SV10	Asco EF8320G174, 3-Way
SV13	Asco 8320G174, 3-Way
SV14	Burkert 6012 Series (Recommended for Advantage®)
SV15	Burkert 6014 Series (Recommended for Advantage®)

Solenoid Voltage (Block X)

Code	Description
V1	120V / 60HZ
V2	24VDC
V3	240V / 60HZ

Advantage® Switch Pack SP-2 (Block Z)

Code	Description	Size
SP2S	Silver Contacts	½"-4"
SP2G	Gold Contacts	½"-4"
SP2Z	2-Wire Proximity	½"-4"
SP2N	NAMUR Proximity	½"-4"
SP2P	3-Wire PNP Proximity	½"-4"
SP2NP	3-Wire NPN Proximity	½"-4"

Advantage® Switch Pack SP-3 (Block Z3)

Code	Description	Size
SP3S48	Silver Contacts 48V	½"-2"
SP3S110	Silver Contacts 110V	½"-2"
SP3G30	Gold Contacts 30V	½"-2"
SP3Z	2-Wire Proximity	½"-2"
SP3N	NAMUR Proximity	½"-2"
SP3P	3-Wire PNP Proximity	½"-2"
SP3NP	3-Wire NPN Proximity	½"-2"

Signal Ranges (Block AB)

Code	Description
SR1	3-15 psi
SR2	6-30 psi
SR3	3-9 psi
SR4	9-15 psi

Filter Regulators (Block AC)

Code	Description
FR1	Conoflow FR95ASKEX1G
FR2	Fisher 67CFR

Transducer (Block AD)*

Code	Description
TR1	Conoflow GT2108ED
TRWS	Watson & Smith 4904-3XR

Speed Controllers (Block AE)

Code	Description
SC	Schrader 337-1001

Special Service / Preparation (Block SPSEPV)

Code	Description
SPEC	Special Service per Customer Specification
VAC	Vacuum
OXY	Oxygen
TOB	Tobacco
WCL2	Wet Chlorine
SIFREE	Silicone-Free
B311	ASME B31.1
B1634	ANSI B16.34
SP88CATB	MSS SP-88 CAT B

*The options listed are for 3–15 psi.

For other optional instrument signals, contact factory.

Ordering Information

Dia-Flo Figure Number Block Sequence for Straightway Valves

Size	Body	Diaphragm	Bonnet	Optional Coatings
Block A	Block B	Block D	Block E	Block N
Dia-Flo [®] Actuator	Position Indicator	Mechanical Accessories	Limit Switches	Additional Options
Block P	Block T	Block V	Block Y	*

The above blocks are the most commonly used. For a complete listing see the Other Blocks listed on page 216.

Manual Valve Example

Figure Number: 3-2834-SS-902

Detailed description:

- 3: 3 Inch Size
- 2834: Cast Iron Body Flanged Ends with No. 10 Hard Rubber Lining
- SS: Natural Rubber Diaphragm
- 902: Cast Iron Handwheel Operated Bonnet Assembly, Indicating

Actuated Valve Example

Figure Number: 2-2811-ST-34-3325

Detailed Description:

- 2: 2 inch size
- 2811: Cast Iron Flanged End ITT Straightway Body
- ST: Neoprene Diaphragm
- 34: Ductile Iron Actuated Bonnet
- 3325: #25 Double Acting (Air-to-Open, Air-to-Close) Actuator

Block A: Size

Code	Description
1	1 Inch
1.5	1.5 Inch
2	2 Inch
2.5	2.5 Inch
3	3 Inch
4	4 Inch
6	6 Inch
8	8 Inch
10	10 Inch
12	12 Inch

Ordering Information

Block B: Body

Straightway Bodies, Unlined

Code	Body Material	Size
2800	No Body (Bonnet Only)	1"-12"

FLANGED*

2811	Cast Iron	1"-12"
2812	Ductile Iron	1"-12"
2813R	Stainless Steel (316)	1"-8"
2815R	Cast Steel	1"-8"

Straightway Bodies, Lined

Code	Lining Material	Size
FLANGED CAST IRON		
2829	ETFE	1"-8"
2831	Neoprene No. 7	1"-12"
2833	Soft Rubber No. 5	1"-12"
2834	Hard Rubber No. 10	1"-12"
2836	Butyl No. 16	1"-12"
2838	Polypropylene (FDA)	1"-8"

FLANGED DUCTILE IRON

2840	Neoprene No. 7	1"-12"
2841	Soft Rubber No. 5	1"-12"
2842	Hard Rubber No. 10	1"-12"
2859	ETFE	1"-8"

*R – Raised Face

Block D: Diaphragms

STRAIGHTWAY TYPE

Code	Material	Size
SB	Black Butyl (FDA)	1"-4"
SS	Natural Rubber	1"-12"
ST	Neoprene	1"-12"
SE	EPDM (FDA)	1"-12"
SC	Hypalon*	1"-4"
SP	BUNA-N (FDA)	1"-2", 3"-6"
EN	Not Supplied	1"-12"

Block E: Bonnet

Bonnets, Handwheel

Code	Bonnet Description
CAST IRON	
902	Indicating
902S	Indicating, Sealed
903	Indicating w/ Travel Stop
903S	Indicating w/ Travel Stop, Sealed

DUCTILE IRON

942	Indicating
942S	Indicating, Sealed
943	Indicating w/ Travel Stop
943S	Indicating w/ Travel Stop, Sealed

Bonnets, Chainwheel

Code	Bonnet Description
CAST IRON	
905	Indicating with Travel Stop
905S	Indicating with Travel Stop, Sealed

Bonnets, Actuated

Code	Bonnet Description
DUCTILE IRON	
34	Actuated
34S	Actuated, Sealed

Block N: Optional Coatings

Code	Description
C1	PVDF Coated Topworks
C2	PVDF Coated Body
C3	PVDF Coated Body & Topworks
C4	White Epoxy Coated Topworks
C5	White Epoxy Coated Body
C6	White Epoxy Coated Body & Topworks

Adapted for But Less ITT Actuation (Block P2)

Code	Description
Y	Valve adapted for But Less Engineered Valves Air Motor

Block P: Dia-Flo® Actuator

Fail Open Actuators (Spring-to-Open Air-to-Close)

Code	Actuator Size
3125	#25
3150	#50
31101	#101
31130	#130
31250	#250

Fail Closed Actuators

(Air-to-Open, Spring-to-Close)

Code	Actuator Size
3225	#25
3250	#50
3275	#75
32101	#101
32130	#130
32250	#250

Code Spring Description

SIZE #25	
3226	101 Spring
3227	101 & 102A Springs
3228	102A Spring

SIZE #50

3251	101 Spring
3252	101 & 102A Springs
3253	97 Spring
3254	96 Spring
3255	96 & 97 Springs
3256	102A Spring

SIZE #75

3273	98 Spring
3274	96 Spring
3276	96 & 97 Springs
3277	97 & 98 Springs
3278	96 & 98 Springs
3279	96, 97 & 98 Springs

SIZE #101

32102	96 Spring
32103	98 Spring
32104	96 & 97 Springs
32105	96 & 98 Springs
32106	97 & 98 Springs
32107	96, 97, & 98 Springs
32108	130 Spring
32109	97 Spring

Fail Closed Actuators (Continued) (Air-to-Open, Spring-to-Close)

SIZE #130	
32131	97 Spring
32132	96 Spring
32133	98 Spring
32134	96 & 97 Springs
32135	96 & 98 Springs
32136	97 & 98 Springs
32137	96, 97, & 98 Springs
32138	130 Spring

SIZE #250

32251	129 & 130 Springs
32252	129 Spring
32253	130 Spring

Double Acting Actuators (Air-to-Open, Air-to-Close)

Code	Actuator Size
3325	#25
3350	#50
3375	#75
33101	#101
33130	#130
33250	#250

Optional Air Motor Covers (Block P1)

Code	Description
DICVR	Ductile Iron

Block T: Position Indicator

Code	Description
P1	Position Indicator

Block V: Mechanical Accessories

Code	Description
AO	Adjustable Opening Stop
ATS	Adjustable Travel Stop
HWO	Handwheel Opening Device
WO	Wrench Opening Device
TOHO	Adjustable Opening Stop and Handwheel Opening Device
TOWO	Adjustable Opening Stop and Wrench Opening Device
HWC	Handwheel Closing Device
TO	Adjustable Opening Stop and Adjustable Travel Stop
THC	Adjustable Opening, Adjustable Travel Stop and Handwheel Closing Device (#25 AM and larger)

Block Y: Limit Switches

Code	Description
LS1	Micro BZE6-2RN
LS2	Micro BAF1-2RN
LS3	Micro DTE6-2RN
LS4	Micro DTF2-2RN
LS5	Micro EX-Q
LS6	Micro EXD-Q-3
LS7	Micro LSA1A
LS8	Westlock 3479 Model 3
LS9	GO 74-13528-A2
LS10	Namco EA700-80100
LS12	Namco EA170-34100 / 35100

*Refer to Factory for Availability

Ordering Information

Optional Limit Switch Position (Block Y1)

Code	Description
LSO	Limit Switch – Open Only
LSC	Limit Switch – Closed Only

Other Blocks

Optional Bonnet Seal Material (Block F)

Code Seal Material

S1	EPDM
S2	Viton

Optional Bonnet Internals (Block H)

Code	Description
M5	Stainless Steel Stem
M8	PVDF Coated Cast Iron Compressor
M9	Stainless Steel Bushing
M11	316 Stainless Steel Stem

Optional Bolting (Block G)

Code Description

B1	Stainless Steel
B1K	SS Bolt / Kolsterised SS Nut
B316	Stainless Steel (316)
B88	B8 Bolt / 8 Nut

Yoke (Block K)

Code	Description
Y	Yoke Supplied

Locking Device (Block L)

Code	Description
LD	Locking Device

Extended Stem (Block M)

Code	Description
EXTSTEMR	Extended Stem - Rim

Non ITT Actuation (Block R)

Code	Description
POF	Non-EV Customer Supplied Actuator (mounted)
POA	Adapted for But Less Customer Supplied Actuator
POM	Non-EV Actuator Supplied and Mounted by Engineered Valves Actuator Hardware

Options (Block U)

Code	Description
HW1	SS Airmotor Bolts
HW2	SS Accessory Brackets
HW3	316 SS Tubing and Fittings
HW4	Plastic Tubing / Brass Fittings
HW5	PVC Coated Tubing / Brass Fittings
HW6	PVC Coated Tubing / SS Fittings

Solenoid Valve (Block W)

Code	Description
SV1	Asco 8320G184
SV2	Asco EF8320G184
SV3	Asco 8345G1
SV4	Asco EF8345G1

Solenoid Voltage (Block X)

Code	Description
V1	120V / 60HZ
V2	24VDC
V3	240V / 60HZ

Filter Regulator (Block AC)

Code	Description
FR1	Conoflow FR95ASKEX1G
FR2	Fisher 67CFR

Speed Control (Block AE)

Code	Description
SC	Schrader 337-1001

Ordering Information

Cross Reference Chart – Bodies, Bonnets and Actuators

Only those figure numbers that have changed are listed below.

Bodies

Old	New
4250	2464
4260	2465
4270	2466

Bonnets

Old	New
2	902
3	903
4	905
6	932
7	933
9	912
10	913
25	942
26	943
30	POA
854	902-C4
855	902S-C4
872	902S-C1
873	903S-C1
874	903S-C1
903	903
904	903S
907	933
910	913
913	913S
923	923
924	923S
926	943
927	943S
955	903-C4
956	903S-C4
963	963
964	963S
974	903S-C1

Dia-Flo® Actuators

Old (Spring #)	New
3112	3112
3212 (88)	3213
3212 (88 & 89)	3214
3212 (88 & Raymond)	3215
3212 (89)	3216
3312	3312
3125	3125
3225 (101)	3226
3225 (101 & 102A)	3227
3225 (102A)	3228
3325	3325
3150	3150
3250 (101)	3251
3250 (101 & 102A)	3252
3250 (97)	3253
3250 (96)	3254
3250 (96 & 97)	3255
3250 (102A)	3256
3350	3350
3275 (96)	3274
3275 (96 & 97)	3276
3275 (97 & 98)	3277
3275 (96 & 98)	3278
3275 (96, 97 & 98)	3279
3375	3375
31101	31101
32101 (96)	32102
32101 (98)	32103
32101 (96 & 97)	32104
32101 (96 & 98)	32105
32101 (97 & 98)	32106
32101 (96, 97 & 98)	32107
32101 (130)	32108
32101 (97)	32109
33101	33101

Dia-Flo® Actuators (Continued)

Old (Spring #)	New
31130	31130
32130 (97)	32131
32130 (96)	32132
32130 (98)	32133
32130 (96 & 97)	32134
32130 (96 & 98)	32135
32130 (97 & 98)	32136
32130 (96, 97 & 98)	32137
32130 (130)	32138
33130	33130
31250	31250
32250 (129 & 130)	32251
32250 (129)	32252
32250 (130)	32253
33250	33250

Switches

Old New

R – Open / Closed	LS1 – LS10
S – Closed Only	
T – Open Only	

Description	Old Code	NEW CODE (#12)		NEW CODE (#25–#250)	
		Fail Open & Double Acting 3100 & 3300	Fail Closed 3200	Fail Open & Double Acting 3100 & 3300	Fail Closed 3200
Position Indicator	Z	P1	P1	P1	P1
Adjustable Travel Stop	X	ATS	ATS	ATS	Standard
Adjustable Opening Stop	W	TOHC	TOWO	AO	AO
Adjustable Opening & Travel Stop	Q	TOHC	TOWO	TO	AO
Handwheel Closing Device	V	TOHC	Not Available	HWC	Not Available
Handwheel Opening Device	JH	Not Available	HWO	Not Available	HWO
Wrench Opening Device	JW	Not Available	WO	Not Available	WO
Adjustable Opening & Travel Stop + Handwheel Closing Device	Q + V	TOHC	Not Available	THC	Not Available
Adjustable Travel Stop + Handwheel Closing Device	X + V	TOHC	Not Available	THC	Not Available
Adjustable Opening Stop + Handwheel Closing Device	W + V	TOHC	Not Available	HWC	Not Available
Adjustable Opening Stop + Handwheel Opening Device	W + JH	Not Available	TOHO	Not Available	TOHO
Adjustable Opening Stop + Wrench Opening Device	W + JW	Not Available	TOWO	Not Available	TOWO

Maintenance Instructions

Installation

In vertical lines, Dia-Flo® diaphragm valves may be installed in any position. In horizontal lines, where drainability is critical, Dia-Flo® valves should be installed with the drain dot or hash mark, located on the end connection close to the body bonnet flange, at 12 O'Clock. This angle is unique to each valve size. Contact the factory if a drain dot or hash mark is not present. In horizontal lines, where drainability is a concern but not critical (typically processes other than pharmaceutical, bioprocessing, food or beverage), the valve should be positioned with the stem at 90 degrees from vertical. In all lines, the bonnet assembly should be positioned with the weep hole (a small hole in the side of the bonnet used as a diaphragm leak detection port) facing down.

Diaphragm Replacement for Handwheel Operated Weir Valve

1. Remove pressure from line containing valve. Rotate handwheel clockwise to just close valve.
2. Remove bonnet nuts.
3. Lift off bonnet and unscrew diaphragm from compressor by turning counterclockwise.
4. Replacement diaphragm should be identical size and grade as original diaphragm. See diaphragm identification drawing below for location of size and grade marking. Thread new diaphragm into compressor handtight, then back off until bolt holes in diaphragm register with bolt holes in bonnet flange.

Note: For PTFE plastic diaphragms, remove elastomer backing cushion included with plastic diaphragm. Replace elastomer backing cushion each time the PTFE diaphragm is changed. PTFE diaphragms are molded in the closed position, but should be inverted to the open position prior to installation to ensure complete (correct) thread engagement. To invert, press with thumbs at center bottom of diaphragm while retaining with fingers at the diaphragm edge.

5. Rotate handwheel counterclockwise just enough to permit flange area of diaphragm to rest flat against flange area of bonnet.
6. Replace valve bonnet on body and tighten bonnet nuts handtight.
7. Close valve fully by rotating handwheel clockwise; then back off one half to one full turn of handwheel. Tighten bonnet nuts evenly with a wrench (per instructions below).
8. Open valve and check bonnet nuts to ensure they are evenly tightened.
9. If diaphragm leaks at body / bonnet joint after reaching temperature and pressure, depressurize system and retighten bonnet nuts.

To Tighten Bonnet Nuts

Prior to pressurization (with the valve open), tighten the bonnet nuts in a crisscross pattern in accordance with chart on next page. Retightening 24 hours after the system reaches operating temperature and pressure is recommended. If leakage occurs at the body/diaphragm seating area, immediately depressurize system and tighten bonnet nuts as noted above. If leakage continues, diaphragm replacement is required.

Diaphragm Identification

Elastomer – 1 piece, made of rubber, with molded-in stud (see tabs).

Note: For diaphragm replacement of actuated valves, see current version of DFAMM on our web site.

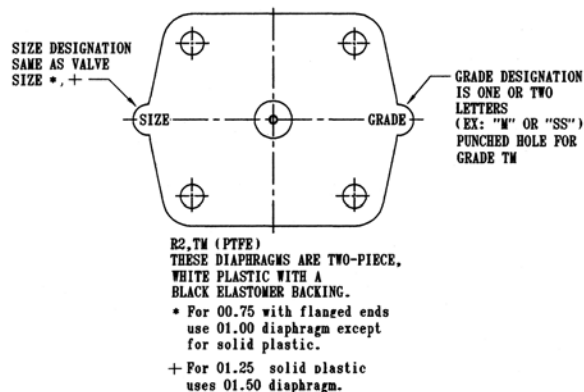

Maintenance Instructions



Handwheel Operated Weir Valve



Handwheel Operated Straightway Valve

Diaphragm Replacement for Handwheel Operated Straightway Valve

Perform steps 1–6 as for Weir Valve.

7. Open valve 2 to 3 turns and tighten bonnet nuts evenly with a wrench (see instructions below).
8. If diaphragm leaks at body/bonnet joint after reaching temperature and pressure, depressurize system and retighten bonnet nuts.

To Tighten Bonnet Nuts

Prior to pressurization (with the valve open), tighten the bonnet nuts in a crisscross pattern in accordance with Table below. Retightening 24 hours after the system reaches operating temperature and pressure is recommended.

If leakage occurs at the body/diaphragm seating area, immediately depressurize system and tighten bonnet nuts as noted above. If leakage continues, diaphragm replacement is required.

Bonnet Fastener Torques in Inch-Pounds

Bonnett		Metal				Plastic
Body		All Weir & Straightway (Except Glass Lined Weir)		Glass Lined, Weir		All
Diaphragm		Elastomer	PTFE	Elastomer	PTFE	All
Size						
IN.	DN.					
1/2	15	40	80	40	40	18
3/4*	20	48	80	48	80	18
1	25	48	100	48	80	25
1 1/4, 1 1/2	32, 40	48	220	48	110	75
2	50	96	275	96	170	100
2 1/2	60	192	575	192	200	—
3	80	300	1000	300	300	420
4	100	192	575	192	360	180
6	150	480	1200	480	600	—
8	200	480	1200	480	600	—
10	250	480	1200	480	—	—
12	300	480	1200	480	—	—

Flange Gasket and Storage Recommendations, Actuator Diaphragm Identification

Flange Gasket Recommendations

The use of a flange gasket is advisable when installing flanged diaphragm valves in a conventional piping system. Flange surfaces are best sealed with elastomeric type gaskets. However, the elastomeric gasket material must be chemically compatible with the service media, and must meet the applicable temperature and pressure requirements.

Plastic lined valves can be installed without a gasket when connecting to plastic lined piping. Installing a plastic lined valve to unlined piping must be avoided due to potential damage to the lining at the flange face, resulting in leakage.

Do not tighten each bolt in consecutive order either in a clockwise or counterclockwise direction. Use the criss-cross method when tightening flange bolts. Consult your piping supplier or piping engineer for the correct torque values to use.

Storage Recommendations

Lined Valves

Lined piping and valves should be stored, between delivery and use, away from direct sunlight, heat or outdoor seasonal weathering. Products with flexible type linings may be stored outdoors, providing the components are covered with protective tarpaulins and are not subjected to extreme temperature conditions.

Equipment lined with semi hard and especially bone hard materials must be protected and stored, preferably indoors, and should never be subjected to extreme cold climatic conditions because thermal stress and expansion may introduce cracking.

Diaphragm Shelf Life and Storage Recommendations

Diaphragm Material	Diaphragm Grade	Diaphragm Shelf Life
Buna N	DP & P	6 Years
Butyl	B & W1	10 Years
EPDM	M, M1 & E1	6 Years
Natural Rubber	S	4 Years
Neoprene	T	6 Years
Polyurethane	—	5 Years
Viton	V	10 Years
PTFE	TM, R2	14 Years

Storage Instructions

Until the diaphragms are to be installed, they should be kept in a covered, adequately ventilated and dry location, preferably in their original containers. Storage temperatures should not cycle rapidly and should be maintained between 40° and 120° F.

Actuator Diaphragm Identification

Actuator Diaphragms							
Size	#12	#25	#50	#75	#101	#130	#250
A	6 ⁵ / ₈ "	9 ⁷ / ₈ "	13 ⁵ / ₁₆ "	14"	15 ¹¹ / ₁₆ "	17 ⁹ / ₁₆ "	21 ⁷ / ₁₆ "
Bolt Holes	12	18	←		NONE		→
maximum recommended air pressure: 85 psi							

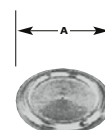

Facts and Recommended Guidelines

Dia-Flo® Diaphragm Valve Facts You Should be Aware of

All .75" flanged valves (except solid plastic) are identical to 1" valves except the body end flanges accommodate .75" flange dimensions. Therefore, bonnet assemblies and diaphragms for such bodies use 1" bonnet assemblies and diaphragms.

Similarly, 1.25" valves (flanged or unflanged) use 1.5" bonnet assemblies and diaphragms.

Diaphragm material properties become weaker with increasing temperature. Therefore, diaphragms operating at elevated temperatures are not to be used at maximum pressures. See pressure / temperature charts.

Cast iron, ductile iron and carbon steel should not be used below -20° F (-29° C) per ANSI standards.

Dia-Flo® Diaphragm Airmotor actuators are designed to operate with air pressures up to 85 psi. The maximum pressure differential between upper and lower chambers is also 85 psi.

Maximum operating line pressure for valves equipped with dualrange bonnet assemblies is 100 psi.

Dualrange® bonnet assemblies are only available on weir type valves, 1" through 6" size.

Straightway valves are not ideal for throttling service due to poor control capability.

Straightway valves are not recommended for vacuum service.

Actuated Dia-Flo® valves used on vacuum service applications will require an additional amount of actuation pressure in order to open the valve. The total amount applied will be higher than that found in the applicable sizing chart, in order to compensate for the effect of the vacuum.

Large fail close (#25 and above) actuators are supplied as standard with travel stops..

Fail open and double acting valves are not normally supplied with travel stops, so if the available supply pressure exceeds the required pressure to close the valve, then the actuator should be ordered with a travel stop option or the supply pressure should be reduced using a regulator.

A minimum of 20 psi line pressure is required to utilize the direct loaded bonnet assembly. Direct loaded bonnets are always provided with diaphragms in the "molded closed" position.

When you specify a double-acting actuator with a topmounted, single-acting positioner, the standard arrangement is that the bottom chamber is supplied with a cushion regulator. This will result in a fail open valve.

Recommended Guidelines for Weir and Straightway Valves

Maximum Velocity

15–20 ft/sec for Clear Liquids

8–10 ft/sec for Slurries

Maximum Solids Percentages

Weir Valves: Not to Exceed 15%

Straightway Valves*: Up to 30%

** For Solids Between 30% and 50%, Consult Factory
50% and Above – Not Recommended*

Maximum Allowable Pressure Drop Across Weir Valve

25% of P_{inlet} Absolute



Industrial Process

Terms & Conditions of Sale

WARRANTY

(a) Company warrants that on the date of shipment the goods are of the kind and quality described herein and are free of non-conformities in workmanship and material. This warranty does not apply to goods or parts delivered by Company but manufactured by others. (b) Buyer's exclusive remedy for nonconformity in any item of the goods shall be the repair or the replacement (at Company's option) of the item and any affected part of the goods. Company's obligation to repair or replace shall be in effect for a period of one (1) year from initial operation of the goods but not more than eighteen (18) months from Company's shipment of the goods, provided Buyer has sent written notice within that period of time to Company that the goods do not conform to the above warranty. Repaired and replacement parts shall be warranted for the remainder of the original period of notification set forth above, but in no event less than 12 months from repair or replacement. At its sole expense, Buyer shall remove and ship to Company any such nonconforming goods and shall reinstall the repaired or replaced goods or parts. Buyer shall grant Company access to the goods at all reasonable times in order for Company to determine any nonconformity in the goods. Company shall have the right of disposal of items replaced by it. If Company is unable or unwilling to repair or replace, or if repair or replacement does not remedy the nonconformity, Company and Buyer shall negotiate an equitable adjustment in the order price, which may include a full refund of the order price for the nonconforming goods. (c) COMPANY HEREBY DISCLAIMS ALL OTHER WARRANTIES, EXPRESS OR IMPLIED, EXCEPT THAT OF TITLE, SPECIFICALLY, IT DISCLAIMS THE IMPLIED WARRANTIES OF MERCHANTABILITY, FITNESS FOR A PARTICULAR PURPOSE, COURSE OF DEALING AND USAGE OF TRADE. (d) Buyer and successors of Buyer are limited to the remedies specified in this article and shall have no others for a nonconformity in the goods. Buyer agrees that these remedies provide Buyer and its successors with a minimum adequate remedy and are their exclusive remedies, whether Buyer's or its successors' remedies are based on contract, warranty, tort (including negligence), strict liability, indemnity, or any other legal theory, and whether arising out of warranties, representations, instructions, installations, or non-conformities from any cause. Buyer shall assume all responsibility and expense for removal, installation and freight in connection with these remedies. (e) Company neither assumes, nor authorizes any person to assume for it, any other obligation in connection with the sale of its goods. This warranty shall not apply to any goods that: (1) have been repaired or altered outside of Company's factories or authorized service centers, in any manner; or (2) have been subjected to misuse, negligence or accidents; or (3) have been improperly stored or handled or used in a manner contrary to Company's instructions or recommendations; or (4) have design errors due to inaccurate or incomplete information supplied by Buyer or its agents.

LIMITATION OF LIABILITY

NEITHER COMPANY, NOR ITS SUPPLIERS SHALL BE LIABLE, WHETHER IN CONTRACT, WARRANTY, FAILURE OF A REMEDY TO ACHIEVE ITS INTENDED OR ESSENTIAL PURPOSES, TORT (INCLUDING NEGLIGENCE), STRICT LIABILITY, INDEMNITY OR ANY OTHER LEGAL THEORY, FOR LOSS OF USE, REVENUE OR PROFIT, OR FOR COSTS OF CAPITAL OR OF SUBSTITUTE USE OR PERFORMANCE, OR FOR INDIRECT, SPECIAL, LIQUIDATED, INCIDENTAL OR CONSEQUENTIAL DAMAGES, OR FOR ANY OTHER LOSS OR COST OF A SIMILAR TYPE, OR FOR CLAIMS BY BUYER FOR DAMAGES OF BUYER'S CUSTOMERS. COMPANY'S MAXIMUM LIABILITY UNDER THIS CONTRACT SHALL BE THE CONTRACT PRICE. BUYER AND COMPANY AGREE THAT THE EXCLUSIONS AND LIMITATIONS SET FORTH IN THIS ARTICLE ARE SEPARATE AND INDEPENDENT FROM ANY REMEDIES WHICH BUYER MAY HAVE HEREUNDER AND SHALL BE GIVEN FULL FORCE AND EFFECT WHETHER OR NOT ANY OR ALL SUCH REMEDIES SHALL BE DEEMED TO HAVE FAILED OF THEIR ESSENTIAL PURPOSE.

GENERAL

(a) Company will comply with all laws applicable to Company during manufacture and sale of the goods. Purchaser will comply with all laws applicable to Purchaser during operation or use of the goods. (b) The laws of the State of New York shall govern the validity, interpretation and enforcement of any order of which these provisions are a part, without giving effect to any rules governing the conflict of laws. The application of the United Nations Convention on Contracts for the International Sale of Goods shall be excluded. (c) Assignment may be made only with written consent of both parties; provided, however, Company may assign to its affiliate without Buyer's consent. (d) Buyer shall be liable to Company for any attorney's fees and costs incurred by Company in enforcing any of its rights hereunder. The document and any other documents specifically referred to as being a part hereof, constitute the entire contract on the subject matter, and it shall not be modified except in writing signed by both parties. Unless otherwise specified, any reference to Buyer's order is for identification only.

ACCEPTANCE

The determination of compliance with performance guarantees will be based on results of factory tests under controlled conditions with calibrated instruments and tested per standards of the Hydraulic Institute, ISO standards, API standards, or other nationally recognized accreditation standards.

STATUTE OF LIMITATIONS

To the extent permitted by applicable law, any lawsuit for breach of contract, including breach of warranty, arising out of the transactions covered by this order, must be commenced not later than twelve (12) months from the date of action accrued.

SHIPMENT

The term "shipment" means delivery to the initial carrier in accordance with the delivery terms of this order. Company may make partial shipments. Company shall select method of transportation and route, unless terms are f.o.b. point of shipment and Buyer specifies the method and route and is to pay the freight costs in addition to the price. When terms are f.o.b. destination or freight allowed to destination, "destination" means common carrier delivery point -within the continental United States, excluding Alaska- nearest the destination. For movement outside the United States, company shall arrange for inland carriage to port of exit and shall cooperate with Buyer's agents in making necessary arrangements for overseas carriage and preparing necessary documents.

SPECIAL SHIPPING DEVICES

On shipments to a destination in the continental United States or Canada, Company has the right to add to the invoice, as a separate item, the value of any special shipping device (barrel, reel, tarpaulin, cradle, crib and the like) used to contain or protect the goods invoiced, while in transit. Full credit will be given on the return to Company of the device in a reusable condition, f.o.b. destination, freight prepaid.

DELAYS

If Company suffers delay in performance due to any cause beyond its control, including but not limited to act of God, war, act or failure to act of government, act or omission of Buyer, fire, flood, strike or labor troubles, sabotage, or delay in obtaining from others suitable services, materials, components, equipment or transportation, the time of performance shall be extended a period of time equal to the period of the delay and its consequences. Company will give Buyer notice in writing within a reasonable time after Company becomes aware of any such delay.

NONCANCELLATION

Buyer may not cancel or terminate for convenience, or direct suspension of manufacture, except with Company's written consent upon terms agreed to by Company.

STORAGE

Any item of the goods on which manufacture or shipment is delayed by causes within Buyer's control, or by causes which affect Buyer's ability to receive the goods, may be placed in storage by Company for Buyer's account and risk and Buyer shall pay all charges for storage and shipping and incidental expenses.

TITLE AND INSURANCE

Title to the goods and risk of loss or damage shall pass to Buyer at the f.o.b. point, except that a security interest in the goods and proceeds and any replacement shall remain in Company, regardless of mode of attachment to realty or other property, until the full price has been paid in cash. Buyer agrees to do all acts necessary to perfect and maintain said security interest, and to protect Company's interest by adequately insuring the goods against loss or damage from any external cause with Company named as insured or co-insured.

INSPECTIONS / EXPEDITING

The Company restricts access to its facilities and requires seventy two (72) hours notice prior to each visit. Company requires that its agents or employees accompany inspectors/expeditors on their visit(s).

TERMS OF PAYMENT

Unless otherwise stated, all payments shall be by Letter of Credit or Net Thirty (30) Days and in United States dollars, and a pro rata payment shall become due as each shipment is made. If shipment is delayed by Buyer, date of readiness for shipment shall be deemed to be date of shipment for payment purposes. If at any time in Company's judgment Buyer may be or may become unable or unwilling to meet the terms specified, Company may require satisfactory assurances or full or partial payment as a condition to commencing or continuing manufacture or making shipment; and may, if shipment has been made, recover the goods from the carrier, pending receipt of such assurances.

GOODS RETURN

Goods can be returned for credit only after receiving Company's written authorization and shipping instructions. Consignor's name and address must be plainly written on the shipping tag. Special goods fabricated to order are not returnable under any conditions.

PATENTS

Company shall pay costs and damages finally awarded in any suit against Buyer or its vendees to the extent based upon a finding that the design or construction of the goods as furnished, infringes a United States patent (except infringement occurring as a result of incorporating a design or modification at Buyer's request), provided that Buyer promptly notifies Company of any charge of infringement, and Company is given the right at its expense to settle such charge and to defend or control the defense of any suit based upon such charge. Company shall have no obligation hereunder with respect to claims, suits or proceedings, resulting from or related to, in whole or in part, (a) the use of software or software documentation, (b) compliance with Buyer's specifications, (c) the combination with, or modification of, the goods after delivery by Company, or (d) the use of the goods, or any part thereof, in the practice of a process. THIS ARTICLE SETS FORTH COMPANY'S ENTIRE LIABILITY WITH RESPECT TO PATENTS.

BUYER DATA

Timely performance is contingent upon the Buyer supplying to the Company, when needed, all required technical information, including drawing approval, and all required commercial documentation.

NUCLEAR

Buyer represents and warrants that the goods covered by this order shall not be used in or in connection with a nuclear facility or application.

PRICES

The prices stated herein will remain firm for the period up to the stated date of shipment providing the shipment is not delayed by the Buyer. If shipment is delayed by the Buyer beyond the shipment date quoted herein, the prices will be based on the prices in effect at time of shipment, including storage and material handling costs. In no event shall the adjusted price be less than the original order price, including change orders. Prices are F.O.B. Shipping Point, unless otherwise specified. When price includes transportation and other charges pertaining to the shipment of goods, any increase in transportation rates and other charges will be for the account of the Buyer. There will be an extra charge for any test other than that which may be normally run by the Company, or for any test performed to suit the convenience of the Buyer. Any applicable duties or sales, use, excise, value added or similar taxes will be added to the price and invoiced separately.

CONTROLLING PROVISIONS

These terms and conditions shall control with respect to any purchase order or sale of the Company's goods. No waiver, alteration or modification of these terms and conditions whether on Buyer's purchase order or otherwise shall be valid unless the waiver, alteration or modification is specifically accepted in writing and signed by an authorized representative of the Company.

EXPORT

If this transaction involves EXPORT, the following additional terms and conditions shall apply:

- Compliance is required for ALL applicable US export laws, and the export laws of the country from where the goods are exported. Buyer acknowledges that it will comply with all applicable export or re-export restrictions and regulatory requirements that it may include US export or re-export restrictions and controls in addition to requirements enforced by other international export control regimes, as applicable. Buyer agrees to full disclosure of all parties to a proposed sales transaction, and to comply with all license terms and conditions, destination control statements, or other restrictions on the export or re-export of Products. Buyer agrees that it will not divert such products to any unauthorized party or destination, including embargoed or sanctioned territories or countries. Buyer will include all information pertaining to export classification (ECCN or equivalent), applicable license restrictions, and authorized destination of the Product in its export and shipping documentation.
- **PACKING**
When packing is available, equipment will be packed, boxed or crated in accordance with the Company's standard commercial practice, for underdeck export shipment, unless otherwise agreed.
- **LETTER OF CREDIT**
Unless otherwise specified in writing, payment shall be made by irrevocable letter of credit in form acceptable to Company, confirmed by a major USA bank, acceptable to the Company and providing for payment in full in United States dollars against presentation of United States inland shipping documents and invoices, such letter of credit to be established prior to Company's acceptance of the order. The letter of credit shall also provide that in the event Company is, for any reason beyond its control, prevented from making shipment from Company's factory or delivery at the port of embarkation, a certificate of manufacture of the whole or any part of the goods shall constitute delivery of such whole or any part of the goods and payment in full of any and all drafts drawn against the letter of credit for the goods so "delivered" shall be made upon presentation of such certificates of manufacture in lieu of United States inland shipping documents. In the event that Company is prevented by law, or otherwise, from making shipment from Company's factory or delivery at port of embarkation of the goods or any part thereof, on completion of manufacture, Company reserved the right to place the goods in storage for the Buyer's account and risk. Any charges incurred in this connection will be for the account of the Buyer at cost and will be payable upon demand. In regions where Letters of Credit are not available, surety bonds will be utilized in lieu of the bank guarantee.
- **COMPANY AS AGENT**
If Company makes or arranges for ocean shipment, Company shall act as agent for the Buyer and reserves the right to procure full insurance coverage, including war risk insurance, at the expense of the Buyer. All expenses incurred in this connection will be payable upon demand to the Company. If Company as agent applies for or secures manufacturing, financing, exporting or other licenses required by the United States Government, or any department thereof, Company shall make such applications or secure such licenses solely as agent for the Buyer, and assumes no responsibility therefore.

Visit our website at
www.engvalves.com

For additional information on other Engineered Valves
products visit www.engvalves.com



ITT Engineered Valves
33 Centerville Road
Lancaster, PA 17603, USA
Tel: +1 (717) 509-2200

Cam-Line, Cam-Tite, Dia-Flo,
EnviZion, Pure-Flo, Skotch

ITT Engineered Valves
1110 Bankhead Avenue
Amory, MS 38821, USA
Tel: +1 (662) 256-7185

Fabri-Valve

ITT Bornemann GmbH
31683 Obernkirchen
Germany
Tel: +49 5724 390-0

EnviZion, Pure-Flo

