

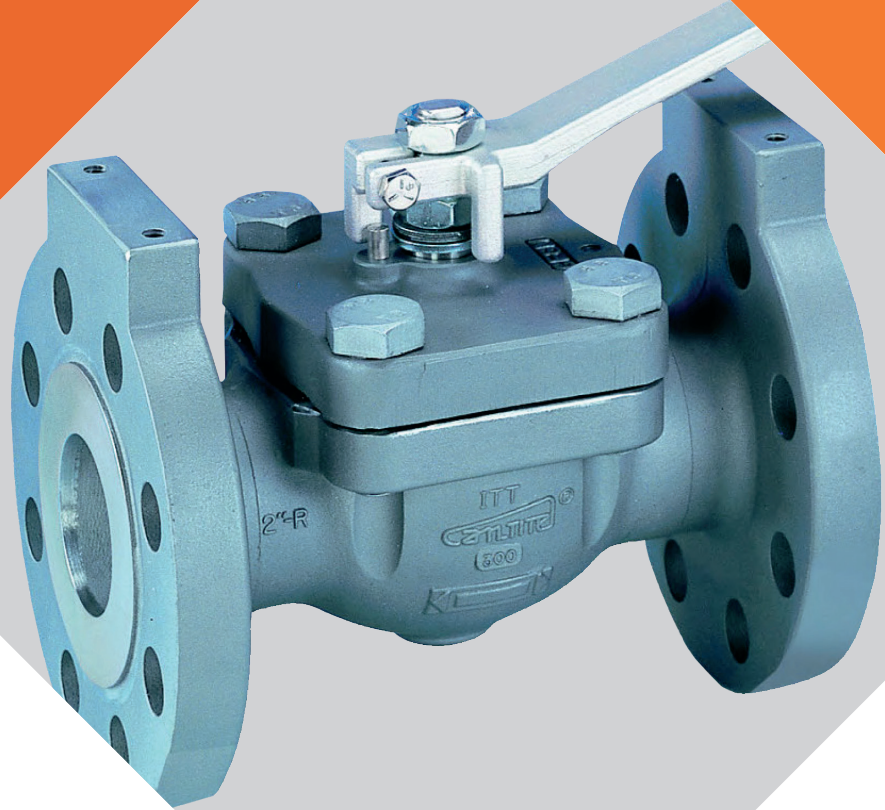

Cam-Tite[®]

Top Entry Metal Ball Valves
for Severe Service Applications



ITT

Contents

	Page		Page
Introduction.....	3	Compact Spring Return.....	21
Quality Assurance	4-5	Dimensions, Weights, Parts Lists.....	22-25
Design Features	6-7	Actuator Mounting Dimensions	26-29
Seat Options.....	8-9	GV Series: Dimensions, Weights	30-33
Ceramic Ball	10	GV Series: Actuator Mounting Dimensions	34-35
Bonnet Options	10-11	Extended and Severe Service Bonnet Dimensions	36-37
Special Services	12	Service Guide.....	38-45
Dry Chlorine Service	13	Exploded Views	46
Special Installations	14	Compliance with National Standards	47
Welding Without Disassembly.....	14	Materials Standards.....	47
Drain Bosses	14	Ordering Information and Figure Numbers	48-50
Extended Stems	14		
Handle Options.....	15		
Pressure / Temperature Ratings.....	16-17		
Flow Coefficients (Cvs)	18		
Valve Operating Torques	19		
Actuated Service	20		

Introduction

Headquartered in Lancaster, PA, ITT Industries Engineered Valves' product line is as extensive as the many industries that we serve. Our 80 year heritage stems from diaphragm valves, of which we are the recognized leader.

Through the years, our product offering has grown extensively. Our corrosion handling expertise has provided the impetus for the design of quarter-turn valve products like our Cam-Tite® Ball Valve.

By developing products such as the Cam-Tite that address specific problems encountered in industry, we continue to expand our commitment to remain a leader in flow control.

The performance of our products is surpassed only by the care taken in the many facets of manufacturing. Excellence in quality assurance, product reliability, and product safety will always remain paramount.



Quality Assurance Measures

Every Valve Is Tested

Each and every standard Cam-Tite Ball Valve receives a seat and hydrostatic shell test prior to shipment. In accordance with MSS-SP-72 and ASME B16.34, this testing includes an 80 PSI air under water seat test and a hydrostatic shell test conducted at 1.5 times the cold working pressure (CWP) rating of the valve. Any visible leakage indicated by the above test procedures, is cause for rejection. With valves prepared for special services, such as dry chlorine, alternate testing measures have been designed to assure product performance.

As further assurance of valve quality, other testing methods such as mass spectrometer or helium leak testing are available upon customer request.

Every Valve Is Tagged

A computer generated stainless steel tag is affixed to each Cam-Tite Ball Valve, pinned to the body. The first line designates the configuration number, which automatically correlates information unique to the pressure class of the valve; its size; body, seat, and seal materials; and other data specific to the valve.

The second line of the tag contains the original order number which is linked to the production traveler for the valve. This traveler contains information relating to the dates on which the valve was assembled, tested, inspected, and finally shipped.

This tag is important documentation to verify the valve configuration installed in the field.

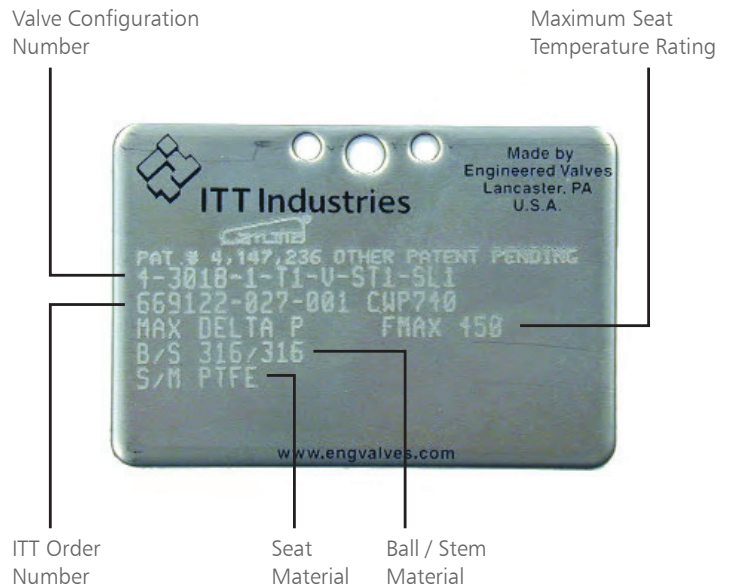

Every Valve Is Inspected

Multiple inspections during the machining of component parts and during assembly ensure the high standards of quality for which the Cam-Tite Ball Valve is noted. Final assembly inspection is preceded by various work-in-progress dimensional checks and assembly process inspections.



Radiography

To augment visual inspection, x-ray examination of major castings is utilized for volumetric evaluation. This option is available upon customer request.

Liquid Penetrant Examination

Surface discontinuities in castings can be evaluated through liquid (dye) penetrant evaluations. This quality assurance method is available upon customer request.



Positive Material Identification

Taking the guesswork out of material identification, an alloy analyzer can provide additional verification of the chemical composition of metallic components. Available upon request.



Certified Documentation

- Positive material identification (PMI)
- Material certifications (CMTRs)
- Certified test reports
- Country of origin
- API 607 Qualified
- Chlorine Institute Pamphlet 6
- Safety Integrity Level (SIL)

Beveled Edge Ball Design

The Geometry Is The Difference

First introduced in 1979, the Cam-Tite Ball Valve has developed a reputation for performance unequaled by conventional floating ball designs. The difference is in the ball, where around the port edge the spherical surface is cut away, forming a bevel that passes completely around the port opening. This is one of the most important design features of the Cam-Tite Ball Valve since it is the difference in the effective distance across the beveled surfaces and the distance across the spherical surface that actually energizes the seat when the valve is closed.

Conventional Floating Ball Design

Floating ball types often sacrifice performance as they depend on line pressure for a dependable seal.

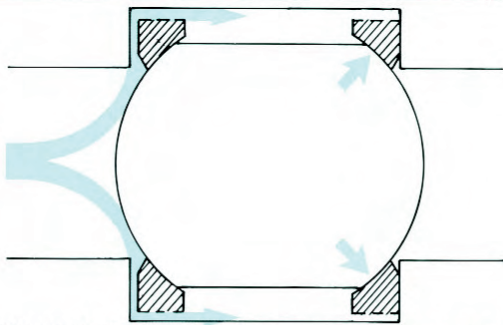

Cam-Tite® Design

Unique non-spherical ball mechanically compresses both upstream and downstream seats to effect a tight, dependable seal independent of line pressure.

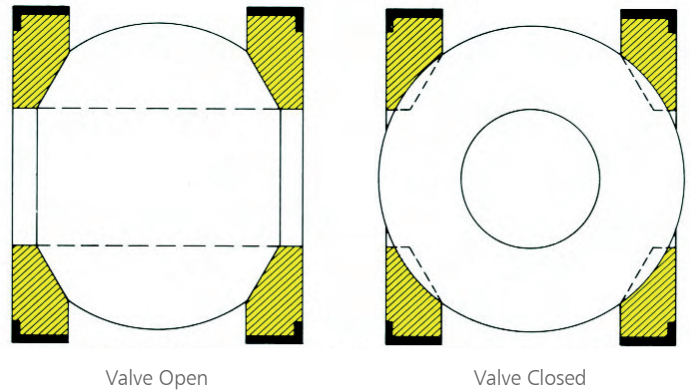

Benefits

- Minimizes pressure on seats to reduce cold flow and extend seat life.
- Eliminates the problem of "breakaway torque" in valves that must rest in the open position for long periods.
- Assures positive sealing regardless of line pressure or pressure differential.
- Eliminates seat damage caused by the leading edge of the ball port cutting into the seat as the ball closes.

Superior Stem Seal Design

Low Torque Makes The Difference

Most stem seals would work well if their only job was to contain the fluid or gas in the piping system. However, stem seals must also serve as bearings and hold the stem in alignment. High operating torques resulting in high lateral loading cause premature stem seal failure in conventional ball and plug valve designs. The Cam-Tite Ball Valve is by design a low torque valve, thereby minimizing lateral loading on the stem seals. In addition, the Cam-Tite stem seals are located further apart, closer to the ends of the stem, reducing the effects of lateral loading.

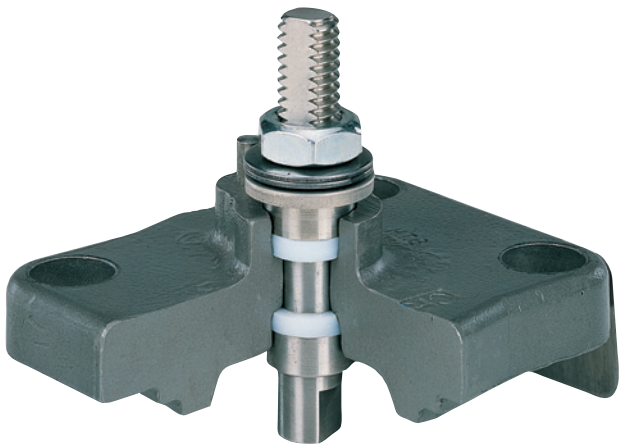

Cam-Tite Ball Valve Seal Assembly

Features and Benefits

- Low operating torque reduces lateral loads on stem seals for superior performance.
- Blow-out proof stem with special attention given to surface finish.
- Upper and lower seals provide balanced loading of stem seals.
- Belleville spring washers provide constant "live load" on stem seals, assuring a tight seal under varying service parameters.

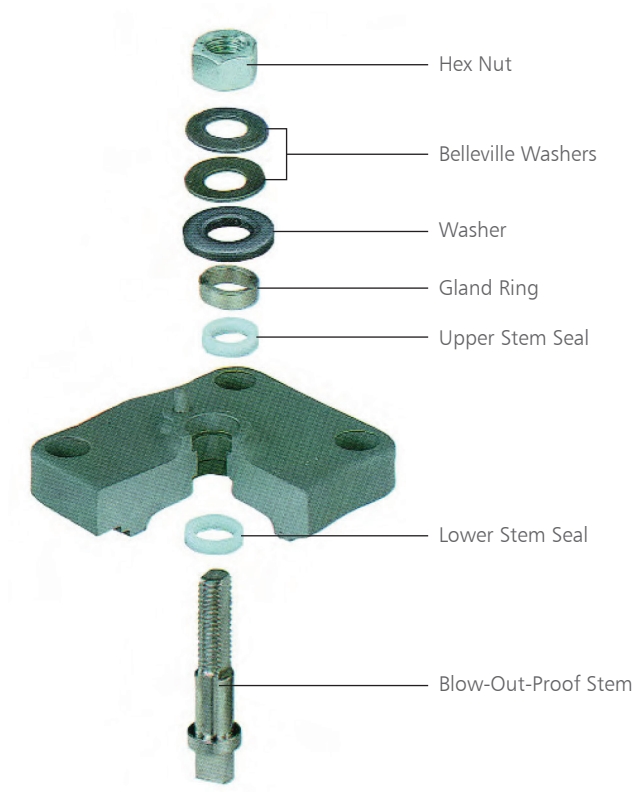

Cam-Tite® Seat Design

PTFE Seats and Seals

All standard PTFE seats and seals are manufactured using unfilled, unpigmented PTFE. Virgin PTFE provides excellent resistance to the most aggressive chemicals and can handle media at both elevated and semi-cryogenic temperatures. Having no filler material, PTFE components are commonly specified for applications where attack of an added filler could occur. Typical applications would be fluorine based chemicals which would attack glass or highly oxidizing media which would deteriorate graphite.

Virgin PTFE is commonly used in Cam-Tite Ball Valves specified for hydrofluoric acid and fluorine gas service. Cam-Tite Ball Valves utilizing virgin PTFE seats and seals have a temperature range of -50° F to 450° F (-45° C to 232° C).

Reinforced PTFE Seats and Seals

For applications that require higher temperature resistance and improved hardness, the Cam-Tite® can be supplied with reinforced PTFE (RTFE) seats and stem seals. These components are glass reinforced and offer a temperature range of -60° F to 520° F (-51° C to 271° C), dependent upon process pressure conditions.

Firesafe Seats and Seals

For applications involving flammable fluids, the Cam-Tite® Ball Valve is available with seat and seals designated Firesafe. Most commonly supplied as reinforced PTFE, Firesafe seats incorporate secondary metal-to-metal seat rings and a special back seal for normal seat operation.

Stem seals combine the fire resistance of graphite with a reinforced PTFE bearing. Cam-Tite® Ball Valves equipped with these components meet the requirements of API 607.

UHMWP Seat and Seal Components

Ultrahigh molecular weight (high density) polyethylene offers abrasion resistance and wear resistance far superior to that of PTFE. Seats and seals of UHMWP provide exceptional service in high cycle applications. The material has a practical temperature limit of 200 degrees F (93° C).

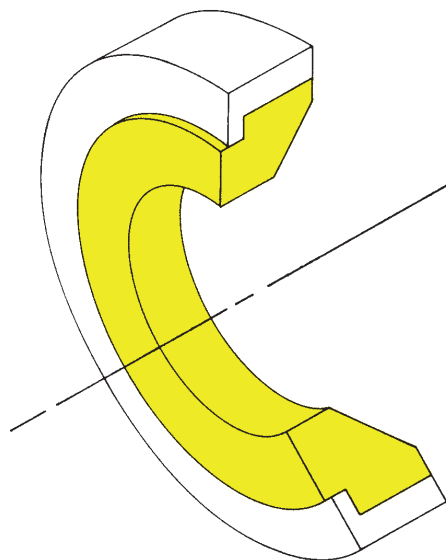

Standard
Seat

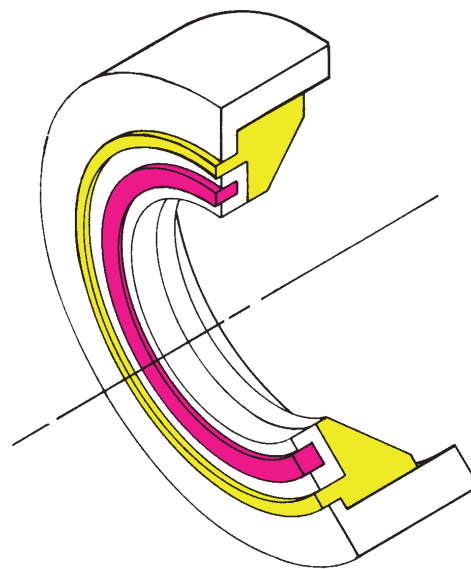

Fire-Safe
Seat

PEEK Seat & Seal Components

PEEK is a tough high temperature engineered thermoplastic offering broad chemical resistance, excellent recovery from deformation, a high degree of dimensional stability, and exceptional resistance to hydrolysis. PEEK has outstanding abrasion resistance and is not sensitive to dynamic fatigue.

G2000 PEEK

Chemical

Since G2000 PEEK is a virgin crystalline polymer, its resistance to chemical attack is excellent. G2000 PEEK is recommended for most environments other than strong oxidizers. It is compatible with numerous acids, bases, and aliphatic and aromatic hydrocarbons.

Steam

Unlike most thermoplastics, G2000 PEEK will not hydrolyze and is recommended for use in steam service and other high-temperature aqueous processes.

Nuclear

G2000 PEEK offers excellent resistance to embrittlement when exposed to gamma radiation. This resistance is maintained in both acid and alkali media.



G3000 PEEK

G3000 PEEK combines the basic properties of the G2000 PEEK with that of carbon graphite and PTFE fillers, yielding a seating material with greater stability at higher temperatures and significantly reduced seating torque. Due to its filled content, G3000 PEEK is an excellent choice for high temperature applications, having a maximum temperature capability of 550° F (288° C).

Table 1

Comparison of typical physical properties

Property	G3000 PEEK	2000 PEEK	PTFE	PTFE Filled
Specific Gravity	1.48	1.32	2.20	2.19
Hardness (Shore)*	D85	D85	D50-55	D50-60
Tensile Strength (psi)	17,000	14,500	4000	2000
Tensile Elongation (%)	5	35	300	200
Flexural Strength (psi)	30,500	16,000	No break	-
Flexural Modulus (psi)	1.45M	550,000	90,000-100,000	-
Shear Strength (psi)				
@ 100F	-	12,000	2,800	3,400
@ 200F	-	11,000	1,900	2,750
@ 300F	7,750	9,000	1,700	2,500
@ 400F	-	6,500	-	-
@ 500F	-	3,800	-	-
Impact Strength Notched IZOD	9	1.6	-	2.7
Tensile (ft-lbs/in)	-	-	30-200	-

*Rockwell "D" Scale

Ceramic Ball, Bonnet Options

Ceramic Ball

The Cam-Tite ceramic ball is an advanced engineering oxide ceramic, which has extremely high strength and fracture toughness.

Features

- Corrosion Resistant*
- Impervious to gases
- Impact Resistant
- Withstands high temperature
- High thermal shock resistance
- Impervious to build-up on the ball
- Excellent choice where ferric chloride build-up is a problem

The ceramic ball can be used with any combination of the available stem and body materials for the Cam-Tite® Ball Valve.



**Consult factory for specific applications.*

Caged Bonnet Option

The patented "Caged Bonnet" was specifically designed to meet the needs of those hazardous applications where a quick and easy turnaround during scheduled maintenance is required. The uniquely designed caged bonnet assembly allows the repair and replacement of all internal components simply by removing the bonnet bolts and lifting off the bonnet assembly. The caged device is available on all bonnet configurations (standard, extended, severe service and bellows) in both nuclear and commercial configurations. The device utilizes a captured (caged) metal saddle that holds the ball, seat rings, seats, grounding springs and cover gasket in place. This device allows the removal and replacement of all components utilizing one subassembly.



Caged bonnet shown on a standard bonnet. US Patent #5,152,502

Extended Bonnet

Cam-Tite Ball Valves can be furnished with extended bonnets for higher temperature or semi-cryogenic services. The extended bonnet allows the valve to be wrapped with insulation without interference from the hand lever and is interchangeable with the standard bonnet. This arrangement raises the stem seal further away from the flowing fluid, thereby reducing the effects of the temperature extremes. The stem is supported to minimize the possibility of galling or stem leakage. The extended bonnet permits the packing nut to extend beyond the valve insulation, thereby permitting stem seal adjustment without disturbing the insulation.



Severe Service Bonnet

The severe service bonnet option was specifically designed to meet the needs of those difficult applications where a true stuffing box is preferred. This design utilizes the extended bonnet as the primary component maintaining the conventional bottom stem seal, augmented by stacked Chevron V-ring packing at the top. The addition of an optional lantern ring and bonnet tap provides for the insertion of compatible lubricants into the packing, inert gas padding, or leak detection. Available in ANSI Class 150 through 600, the severe service bonnet option brings a modular approach to the stem sealing system of the Cam-Tite® Ball Valve.

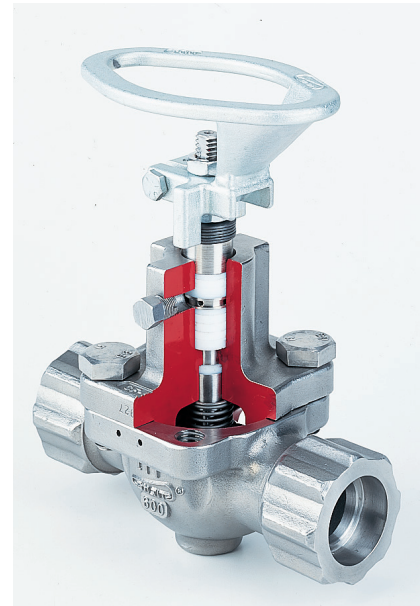

Bellows Stem Seal

Cam-Tite® Ball Valves are also available with a bellows stem seal. This stem seal device provides a hermetic stem seal via a unique quarter-turn bellows design. The interface design for the bellows stem seal to the Cam-Tite Ball Valve was a joint effort between Engineered Valves and Kerotest in which the bellows assembly becomes integral to the bonnet of the valve. This allows for disassembly should replacement of internal components be required. The device can also be easily actuated. Bellows stem seals are available in ANSI Class 150 and 300 in a variety of materials.



Note: Standard, extended, severe service, and bellows stem seal bonnet operators are interchangeable within the same size and pressure class valve.

The Trusted Name for Severe Services

Since 1979 the Cam-Tite Ball Valve has become a performance leader in tough-to-handle services. The combination of the patented sealing arrangement and the superior stem seal design has ushered the Cam-Tite® into services where its design superiority has proven itself over plug valves and conventional floating ball type valves. Among the services where Cam-Tite® Ball Valves have emerged as the solution are the following:

- Dry Chlorine
- Phosgene
- Anhydrous HF
- Anhydrous Ammonia
- Anhydrous HCL
- High Vacuum
- PCL_3
- Steam
- VOCs

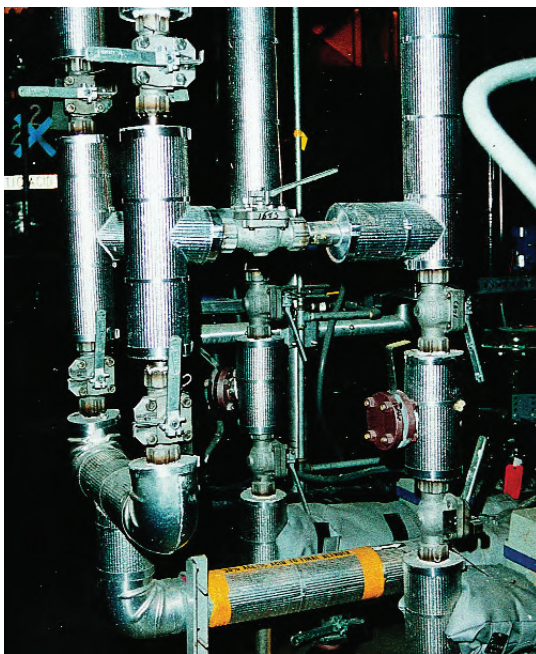

Anhydrous HF Acid Service

Numerous years of field application experience has led to a recommended construction for Cam-Tite® Ball Valves in anhydrous hydrofluoric acid. With a variety of body materials to choose from, valves prepared for HF service normally incorporate inconel 600 bonnet bolting, inconel 718 belleville washers, a stainless steel rotational stop (in applicable sizes), and virgin PTFE seats and seals. Additionally, all HF valves are specially assembled, cleaned, and tested. Specify "Prepared for HF Service" using code "HF" in the valve configuration number.

Oxygen Service

Cam-Tite® Ball Valves can be prepared for oxygen service. These valves are subjected to rigid procedures to ensure that they are free from all burrs, chips, and dirt. They are specially assembled, cleaned, tested and packaged. Valves prepared for oxygen are lubricated with DuPont Krytox® GPL 206 unless otherwise specified. Order valves "Prepared for Oxygen Service" using "OX" in the configuration number.

Vacuum Service

The Standard Cam-Tite Ball Valve is suitable for vacuum services down to 20 microns absolute. For vacuum conditions below 20 microns absolute high vacuum valves can be supplied. High vacuum service valves are manufactured with special attention to seat and seal tolerances and finishes and are specially cleaned and packaged. These valves have leakage rates less than 1×10^{-7} STD. CC/sec as verified by a mass spectrometer test. Specify valves "Prepared for High Vacuum Service" using code "VAC" in the configuration number.

See pages 48-50 for additional ordering information for Cam-Tite® Ball Valves prepared for the above special services.

The Proven Leader in Dry Chlorine

In dry chlorine service, valves must be capable of absolute shutoff while maintaining piping system integrity (no stem seal leakage). For cost-effectiveness, they must also offer long service life. Simple enough, yet the punishing nature of chlorine handling has defeated many types of chlorine valves and forced users to accept compromises in performance and safety. Such compromises are no longer necessary. Thousands of installed Cam-Tite® Valves are demonstrating their superiority, based on three important features:

- **Patented Ball Design**
Assures zero leakage through the valve.
- **Superior Stem Seals**
Prevents leakage to the atmosphere.
- **Positive Valve Body Vent**

Positive Relief

In accordance with the Chlorine Institute Pamphlet #6, all dry chlorine ball valves must be equipped to relieve excess pressure in the ball cavity toward the direction of high pressure. This is an important safety feature, ensuring that excess pressure in a closed valve will bleed off harmlessly. Cam-Tite® Ball Valves prepared for dry chlorine service are equipped with a positive vent in the valve body as opposed to competitive designs that rely on self-relieving seats or vents through the ball or plug. Experience has proven that self-relieving seats do not provide predictable performance.

Placing the vent in the body eliminates the possibility of installing a vented ball or plug backwards. A positive body vent is the only way to provide predictable, repeatable safety relief.

Note: Cam-Tite Ball Valves supplied with vented bodies are considered unidirectional with regards to shut-off.

Chlorine Valve Preparation

Preparation in accordance with the Chlorine Institute Pamphlet #6 includes:

- A relief vent in the body to bypass the upstream seat.
- A cast arrow on the body to indicate the direction of pressure tightness.
- Special cleaning of all valve components.
- Special testing for seat tightness and relief port venting.
- Special packaging and marking.

Cam-Tite® Ball Valves for dry chlorine service are usually supplied with cast carbon steel (ASTM A216 Gr. WCB) bodies, monel ball and stem, and reinforced PTFE seats, seals and cover gasket. Other materials, including alloy 20, hastelloy, and ceramic are commonly used in chlorine services and are available as required.

When ordering valves "Prepared for Dry Chlorine Service," specify code "CLV" in the configuration number.

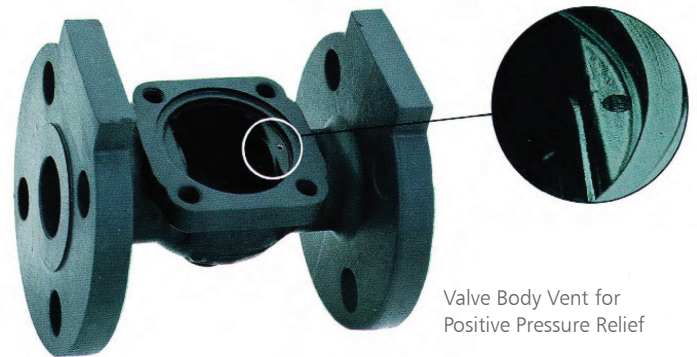

Special Installations

Welding Without Disassembly

Cam-Tite® Ball Valves can be welded into the pipeline without disassembly provided certain procedures and precautions are followed. The valve must be in the open position during welding and should remain open until it cools to ambient temperature. Welding procedures in accordance with Section IX of the ASME Boiler and Pressure Vessel Code should be utilized. In addition, a Tempilstik (350° F for PTFE and RTFE seats and seals or 200° F for UHMWP seats and seals) must be used to monitor the temperature at the seat / gasket area. This is the area in line with the body / cover flange as shown above. Welding should be controlled such that the maximum temperature in this area remains below that of the rated Tempilstik. A tremendous amount of time and trouble associated with the dismantling and reassembly of welded valves is avoided, but more importantly, the integrity of the factory hydrostatic and seat testing is maintained when following these procedures.

See page 47 for weld end machining standards.

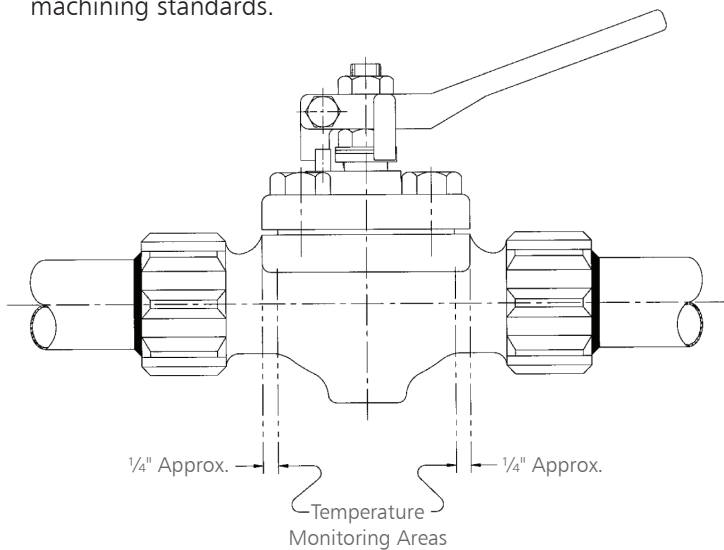

Drilled, Tapped And Plugged Drain Bosses

All Cam-Tite® Ball Valves have an integrally cast drain boss on the bottom side of the body. This drain boss can be drilled, tapped, and plugged if draining of the valve cavity is required. The standard drilling is 1/4" NPT on 1/2" through 2" sizes and 1/2" NPT on 3" through 6" sizes. Carbon steel valves are furnished with ASTM A193 GR B7 plugs while stainless steel valves are furnished with ASTM A193 GR B8 plugs. (Consult the factory for specifications of drain plugs supplied on other body materials.) Specify valves "Prepared with Tapped and Plugged Drain Port" using code "D" in the configuration number when ordering.

Stem Extensions

The Cam-Tite® Ball Valve can be supplied with a variety of designs to support applications which require extended stems. Stem extensions can be provided in carbon steel and stainless steel materials of construction and can be specified in a wide range of lengths for complete versatility.

See pages 48-50 for information on ordering stem extensions for Cam-Tite® valves.

Handle Options

Oval Safety Handwheels

Oval safety handwheels are available on Cam-Tite® Ball Valves ½" through 2". These handwheels are used where the standard hand levers could be accidentally bumped open or closed. The oval safety handwheels are either cast carbon steel or cast stainless steel. The oval shape provides quick, easy identification of valve position.

Specify "Prepared with Oval Safety Handwheel" using code "HD2" (carbon steel) or code "HD3" (stainless steel) in the configuration number.

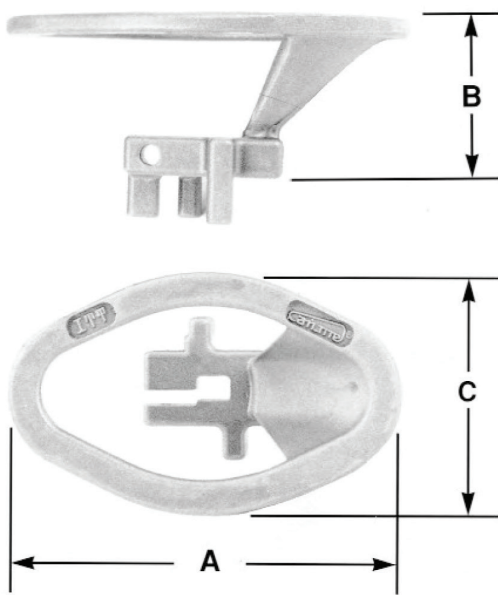

DIMENSIONS (INCH)

Valve Size	A	B	C
½" = 1"	5.0	2.03	3.0
1½"	6.5	2.03	4.0
2"	6.5	2.03	4.0

DIMENSIONS (MM)

½" = 1"	127	52	76
1½"	165	52	102
2"	165	52	102

Spring Return Handle Options

The Cam-Tite Ball Valve can be supplied with either a manual spring return handle (dead man's handle) or a fire-safe fusible linked spring return handle for safety shut-off of manually operated valves.

Chain Operator Options

The Cam-Tite Ball Valve can be provided with a T-handle and chain for operation in services where access to the valve is limited. The T-handle operator can be supplied for installation in either vertical or horizontal pipelines and is available in both carbon steel and stainless steel construction.

Lock Out Device Option

OSHA 1910.147 requires that valves in certain applications have a method of being locked out in the closed position to prevent unauthorized opening. The Cam-Tite® Ball Valve can be supplied with a locking device which will lock the valve in either the open or closed position. The standard locking device is constructed of stainless steel and can be provided on any of the optional bonnet designs. Specify "Prepared with Locking Device" using code "LDS" in the configuration number for the valve.

See pages 48-50 for additional ordering instructions for Cam-Tite® valves prepared with the above handle options.

Pressure / Temperature Ratings

Class 150 Flanged, Buttweld

Cold Working Pressure (PSIG)	
Carbon Steel - WCB	285
Stainless Steel - CF8M, CF3M	275
Alloy 20 - CN7M	230
Monel M-35-1	230
Hastelloy CW-6M	290
Titanium - B367 Gr C3	265

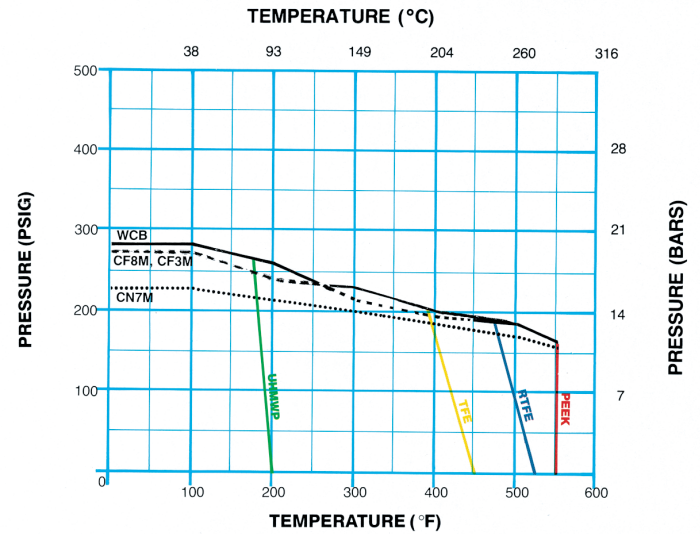

Class 150-300 Screwed, Socket Weld Class 300 Flanged, Buttweld

Cold Working Pressure (PSIG)	
Carbon Steel - WCB	740
Stainless Steel - CF8M, CF3M	720
Alloy 20 - CN7M	600
Monel M-35-1	600
Hastelloy CW-6M	750
Titanium - B367 Gr C3	695

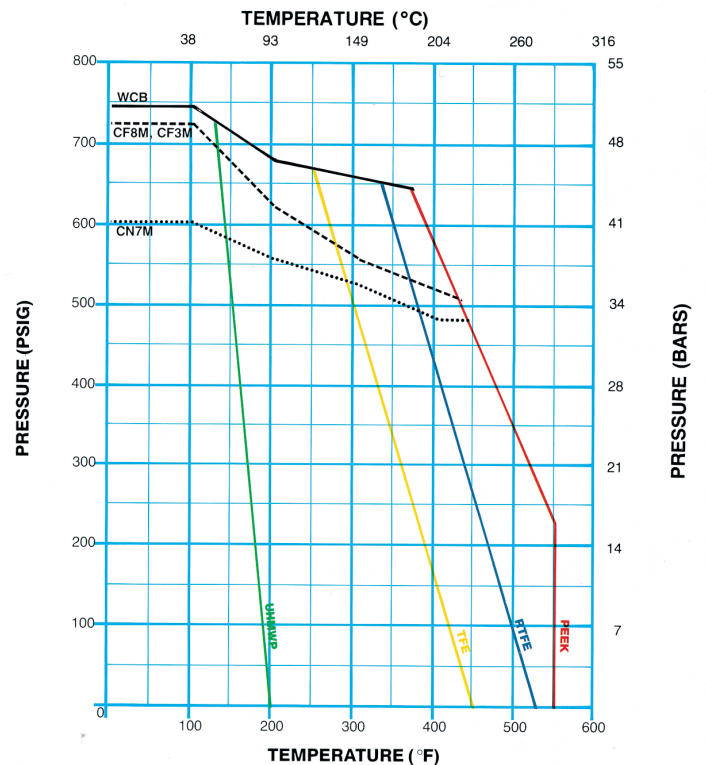

Class 600 Flanged, Butt-weld
Screwed, Socket Weld

Cold Working Pressure (PSIG)	
Carbon Steel - WCB	1480
Stainless Steel - CF8M, CF3M	1440
Alloy 20 - CN7M	1200
Monel M-35-1	1200
Hastelloy CW-6M	1500
Titanium - B367 Gr C3	1390

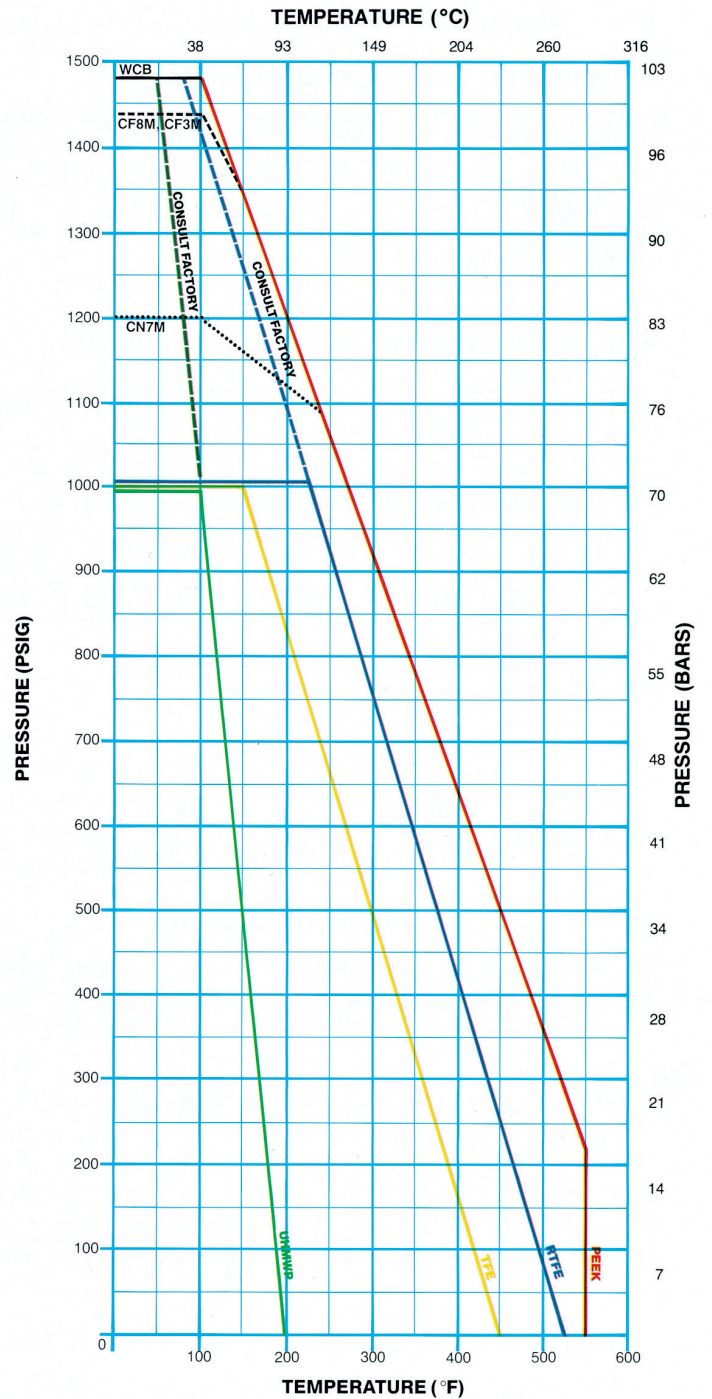

Note: Consult factory for pressure / temperature recommendations for 3" and larger Class 600 fire-safe seats

Flow Coefficients (Cv)

Cv = Flow of water in US gallons per minute through the valve with a one psi pressure drop.

Note: Consult factory for recommendations on valves intended for throttling or modulating services.

Class 150 Flanged and Butt weld

Degrees Open From Closed	10°	20°	30°	40°	50°	60°	70°	80°	90°
1/2"	–	–	0.1	0.3	0.9	1.4	2.2	3.5	8.4
3/4"	–	–	0.2	1.2	2.2	3.7	5.4	8.0	17.0
1"	–	–	0.2	1.1	2.5	4.6	7.6	12.8	30.0
1 1/2"	–	–	1.0	3.0	5.5	11.0	17.5	33.5	73.0
2"	–	0.5	3.0	6.5	11.5	21.0	39.0	81.5	160.5
3"	–	0.5	3.7	12.4	22.9	42.4	81.5	181.0	355.0
4"	–	1.1	7.8	26.1	48.4	89.7	172.5	383.4	751.6
6"	–	–	–	–	–	–	–	–	1500

Class 300 Flanged and Butt weld

Degrees Open From Closed	10°	20°	30°	40°	50°	60°	70°	80°	90°
1/2"	–	–	0.1	0.3	0.7	1.2	2.1	3.8	8.4
3/4"	–	–	0.2	0.8	1.6	2.8	5.0	9.5	18.2
1"	–	–	0.2	1.0	2.4	4.6	8.0	15.6	31.6
1 1/2"	–	1.0	2.5	5.5	10.0	17.5	29.0	51.0	80.0
2"	–	1.0	3.0	6.5	13.5	22.0	39.0	72.0	163.0
3"	–	2.5	8.4	17.9	34.5	57.5	99.2	180.3	360.5
4"	–	5.3	17.8	37.9	73.0	121.7	209.9	381.6	763.3
6"	–	–	–	–	–	–	–	–	1500.5

Class 600 Flanged and Butt weld

Degrees Open From Closed	10°	20°	30°	40°	50°	60°	70°	80°	90°
1/2"	–	–	0.1	0.3	0.8	1.3	2.2	3.5	8.5
3/4"	–	–	0.2	0.9	1.9	3.4	5.6	8.2	17.0
1"	–	–	0.2	0.8	1.9	3.8	7.0	14.2	28.4
1 1/2"	–	–	0.5	3.5	9.5	17.0	31.0	55.0	81.0
2"	–	0.9	3.0	6.0	11.5	21.0	39.0	87.0	163.0
3"	–	1.4	4.7	11.2	28.1	51.1	94.6	197.1	365.0
4"	–	2.9	9.9	23.6	59.1	107.4	198.9	414.5	767.5

Screwed and Socket Weld – All Classes

Degrees Open From Closed	10°	20°	30°	40°	50°	60°	70°	80°	90°
1/2"	–	–	0.1	0.2	0.7	1.2	2.1	3.6	8.4
3/4"	–	–	0.2	0.7	1.6	2.9	5.0	8.5	17.0
1"	–	–	0.5	0.7	2.0	3.8	6.8	12.5	30.8
1 1/2"	–	1.0	2.5	5.0	9.5	15.5	24.5	45.0	78.4
2"	–	1.0	3.0	6.0	11.5	21.0	38.5	76.5	158.5
3"	–	2.9	8.4	16.8	32.3	53.9	96.3	181.7	349.5

Valve Operating Torques

The actual amount of torque required to operate a valve is dependent upon many variables, such as line pressure, temperature, type of fluid, and frequency of operation. The following tables are based on the maximum breakaway / closing torque requirements of a Cam-Tite®

Ball Valve handling a clean, particle free liquid. For valves used in heavy liquids, high particulate fluids, gases, or sub-zero temperatures, consult the factory for actual torque recommendations.

UNFILLED PTFE

PRESSURE DROP ACROSS VALVE			
SIZE	Class 150	Class 300	Class 600
1/2", 3/4", 1"	75 in-lb	75 in-lb	75 in-lb
1 1/2"	85 in-lb	85 in-lb	85 in-lb
2"	175 in-lb	175 in-lb	175 in-lb
3"	435 in-lb	435 in-lb	450 in-lb
4"	525 in-lb	770 in-lb	925 in-lb
6"	1270 in-lb	1615 in-lb	N/A

FIRESAFE REINFORCED PTFE

PRESSURE DROP ACROSS VALVE			
SIZE	Class 150	Class 300	Class 600
1/2", 3/4", 1"	115 in-lb	115 in-lb	115 in-lb
1 1/2"	150 in-lb	150 in-lb	160 in-lb
2"	325 in-lb	325 in-lb	350 in-lb
3"	735 in-lb	750 in-lb	1700 in-lb
4"	890 in-lb	1545 in-lb	2535 in-lb
6"	2300 in-lb	2650 in-lb	N/A

REINFORCED PTFE (RTFE)

PRESSURE DROP ACROSS VALVE			
SIZE	Class 150	Class 300	Class 600
1/2", 3/4", 1"	105 in-lb	105 in-lb	105 in-lb
1 1/2"	110 in-lb	110 in-lb	110 in-lb
2"	220 in-lb	220 in-lb	235 in-lb
3"	590 in-lb	590 in-lb	640 in-lb
4"	695 in-lb	895 in-lb	1195 in-lb
6"	1355 in-lb	1730 in-lb	N/A

UHMW POLYETHYLENE

PRESSURE DROP ACROSS VALVE			
SIZE	Class 150	Class 300	Class 600
1/2", 3/4", 1"	95 in-lb	95 in-lb	95 in-lb
1 1/2"	120 in-lb	120 in-lb	120 in-lb
2"	260 in-lb	260 in-lb	260 in-lb
3"	620 in-lb	620 in-lb	785 in-lb
4"	795 in-lb	795 in-lb	1080 in-lb
6"	1555 in-lb	1555 in-lb	N/A

G3000 PEEK

PRESSURE DROP ACROSS VALVE			
SIZE	Class 150	Class 300	Class 600
1/2", 3/4", 1"	195 in-lb	195 in-lb	195 in-lb
1 1/2"	240 in-lb	265 in-lb	265 in-lb
2"	340 in-lb	375 in-lb	695 in-lb
3"	1285 in-lb	1345 in-lb	1705 in-lb
4"	1400 in-lb	1610 in-lb	2665 in-lb
6"	N/A	N/A	N/A

G2000 PEEK

PRESSURE DROP ACROSS VALVE			
SIZE	Class 150	Class 300	Class 600
1/2", 3/4", 1"	195 in-lb	195 in-lb	195 in-lb
1 1/2"	250 in-lb	250 in-lb	250 in-lb
2"	375 in-lb	555 in-lb	960 in-lb
3"	1400 in-lb	1595 in-lb	2500 in-lb
4"	2055 in-lb	2775 in-lb	3960 in-lb
6"	N/A	N/A	N/A

Maximum Allowable Stem Torques

The following torque values represent the maximum allowable torque which can be applied to a specific valve size and stem material before permanent damage to the stem occurs.

These values should not be exceeded when sizing power actuators for application with the Cam-Tite® Ball Valve.

STEM MATERIAL								
SIZE	316 ss	Monel	Alloy 20	Hastelloy 276	Inconel 625	Nickel	Titanium	Inconel 718
1/2", 3/4", 1"	460 in-lb	390 in-lb	275 in-lb	275 in-lb	275 in-lb	275 in-lb	320 in-lb	550 in-lb
1 1/2"	590 in-lb	505 in-lb	355 in-lb	355 in-lb	355 in-lb	355 in-lb	415 in-lb	700 in-lb
2"	1040 in-lb	1110 in-lb	785 in-lb	785 in-lb	785 in-lb	785 in-lb	915 in-lb	1560 in-lb
3"	4660 in-lb	4300 in-lb	2510 in-lb	2940 in-lb	4300 in-lb	3580 in-lb	5020 in-lb	8600 in-lb
4"	4800 in-lb	5760 in-lb	3360 in-lb	3940 in-lb	5760 in-lb	4800 in-lb	6730 in-lb	11500 in-lb
6"	14500 in-lb	29100 in-lb	17000 in-lb	19900 in-lb	29100 in-lb	24310 in-lb	34000 in-lb	50400 in-lb

Consult factory for stem materials not listed above.

Actuated Service

By virtue of its low torque design, the Cam-Tite® Ball Valve is an inexpensive and easy valve to actuate. The low-torque feature allows the valve to be actuated with a much smaller and more cost effective actuator. This means you have the superior performance of the Cam-Tite® Ball Valve at a lower package cost than with conventional ball or plug valves.

When it comes to actuated "isolation" valves, the Cam-Tite® is truly unique. To begin with, since there is virtually no load on the seats when the valve rests in the open position, the seats remain in prime condition waiting to be called into service. Since there is no "breakaway" when moving from the open to closed positions, the actuator is set into motion without opposing load. Only when the valve is essentially closed does the valve operating torque reach design peak. It is nice to know that when peak load is reached, the valve is already closed.



Engineered Valves can supply actuator packages utilizing the Compact rack and pinion actuator or any other actuator suited to your needs. Actuator packages are completely assembled and tested by Engineered Valves to meet our highest standards of quality.

Typical actuator mounting is accomplished either by utilizing the flange pads on flanged end valves or by replacing the cover bolts with studs and double nuts on socket, threaded and buttweld configurations. Both methods allow the removal of the actuator without disturbing the body / cover seal.

If field mounting of actuation is necessary, the following guidelines should be followed:

- Use flange pad mounting when available. If not, then machined studs must be used – not threaded rod.
- It is recommended that if the bonnet is loosened, then the cover gasket should be replaced.
- The rotational stop pin in the cover (3", 4" and 6") should be removed. Open / closed positioning should be accomplished by proper adjustment of the actuator travel stops.

See pages 22-37 for actuator mounting details.



Actuator Sizing

Compact Spring Return

PTFE (ST1)

Valve Size	DN	Class 150		Class 300		Class 600	
		60 psi / 4 bar	80 psi / 5.5 bar	60 psi / 4 bar	80 psi / 5.5 bar	60 psi / 4 bar	80 psi / 5.5 bar
1/2" - 1"	15-25	C25-2A2B	C20-2B	C25-2A2B	C20-2B	C25-2A2B	C20-2B
1.5	40	C25-2A2B	C20-2B	C25-2A2B	C20-2B	C25-2A2B	C20-2B
2	50	C30-2A2B	C25-2C	C30-2A2B	C25-2C	C35-2A2B	C25-2C
3	80	C45-2A2B	C35-2C	C45-2A2B	C35-2C	C35-2A2B	C35-2C
4	100	C45-2A2B	C35-2C	C60-2A2B	C45-2C	C60-2A2B	C45-2C
6	150	C60-2A2B	C60-2C	C60-2A2B	C60-2C		

RTFE (ST2)

Valve Size	DN	Class 150		Class 300		Class 600	
		60 psi / 4 bar	80 psi / 5.5 bar	60 psi / 4 bar	80 psi / 5.5 bar	60 psi / 4 bar	80 psi / 5.5 bar
1/2" - 1"	15-25	C25-2A2B	C25-2C	C25-2A2B	C25-2C	C25-2A2B	C25-2C
1.5	40	C25-2A2B	C25-2C	C25-2A2B	C25-2C	C25-2A2B	C25-2C
2	50	C30-2A2B	C30-2C	C30-2A2B	C30-2C	C35-2A2B	C30-2C
3	80	C45-2A2B	C45-2C	C45-2A2B	C45-2C	C45-2A2B	C45-2C
4	100	C45-2A2B	C45-2C	C60-2A2B	C45-2C	C60-2A2B	C60-2C
6	150	C60-2A2B	C60-2C	C75-2A2B	C60-2C		

G3000 PEEK (ST7)

Valve Size	DN	Class 150		Class 300		Class 600	
		60 psi / 4 bar	80 psi / 5.5 bar	60 psi / 4 bar	80 psi / 5.5 bar	60 psi / 4 bar	80 psi / 5.5 bar
1/2" - 1"	15-25	C30-2A2B	C25-2C	C30-2A2B	C30-2C	C30-2A2B	C30-2C
1.5	40	C35-2A2B	C25-2C	C35-2A2B	C30-2C	C35-2A2B	C30-2C
2	50	C35-2A2B	C30-2C	C45-2A2B	C35-2C	C45-2A2B	C45-2C
3	80	C60-2A2B	C60-2C	C60-2A2B	C60-2C	C75-2A2B	C60-2C
4	100	C60-2A2B	C60-2C	C60-2A2B	C60-2C	C75-2A2B	C75-2C

Fire-Safe RTFE, PTFE (ST3, ST4)

Valve Size	DN	Class 150		Class 300		Class 600	
		60 psi / 4 bar	80 psi / 5.5 bar	60 psi / 4 bar	80 psi / 5.5 bar	60 psi / 4 bar	80 psi / 5.5 bar
1/2" - 1"	15-25	C25-2A2B	C25-2C	C25-2A2B	C25-2C	C25-2A2B	C25-2C
1.5	40	C30-2A2B	C25-2C	C30-2A2B	C25-2C	C30-2A2B	C25-2C
2	50	C35-2A2B	C35-2C	C35-2A2B	C35-2C	C35-2A2B	C35-2C
3	80	C45-2A2B	C45-2C	C45-2A2B	C45-2C	C75-2A2B	C60-2C
4	100	C60-2A2B	C45-2C	C60-2A2B	C60-2C	C75-2A2B	C75-2C
6	150	C75-2A2B	C60-2C	C75-2A2B	C75-2C		

UHMW Polyethylene (ST5)

Valve Size	DN	Class 150		Class 300		Class 600	
		60 psi / 4 bar	80 psi / 5.5 bar	60 psi / 4 bar	80 psi / 5.5 bar	60 psi / 4 bar	80 psi / 5.5 bar
1/2" - 1"	15-25	C25-2A2B	C25-2C	C25-2A2B	C20-2C	C25-2A2B	C20-2B
1.5	40	C25-2A2B	C25-2C	C30-2A2B	C25-2C	C25-2A2B	C25-2C
2	50	C35-2A2B	C30-2C	C35-2A2B	C30-2C	C35-2A2B	C30-2C
3	80	C45-2A2B	C45-2C	C45-2A2B	C45-2C	C60-2A2B	C45-2C
4	100	C60-2A2B	C45-2C	C60-2A2B	C45-2C	C60-2A2B	C60-2C
6	150	C60-2A2B	C60-2C	C60-2A2B	C60-2C		

G2000 PEEK (ST6)

Valve Size	DN	Class 150		Class 300		Class 600	
		60 psi / 4 bar	80 psi / 5.5 bar	60 psi / 4 bar	80 psi / 5.5 bar	60 psi / 4 bar	80 psi / 5.5 bar
1/2" - 1"	15-25	C30-2A2B	C25-2C	C30-2A2B	C30-2C	C30-2A2B	C30-2C
1.5	40	C35-2A2B	C30-2C	C35-2A2B	C30-2C	C35-2A2B	C30-2C
2	50	C45-2A2B	C35-2C	C45-2A2B	C45-2C	C60-2A2B	C45-2C
3	80	C60-2A2B	C60-2C	C60-2A2B	C60-2C	C75-2A2B	C75-2C
4	100	C75-2A2B	C60-2C	C75-2A2B	C75-2C	NA	C75-2C

Note:

1. Actuator sizing based on 20% safety factor.
2. Use higher safety factor when handling gases, viscous liquids and crystallizing media.

Double Acting

ACTUATOR SIZE	OPERATING PRESSURE (PSI)					
	20	40	60	80	100	120
15	39	79	119	160	199	239
20	79	158	238	318	398	478
25	160	320	480	640	800	960
30	267	537	806	1074	1343	1611
35	471	941	1412	1882	2353	2824
45	907	1813	2719	3626	4532	5438
60	2149	4298	6446	8595	10744	12893
75	3765	7530	11295	15060	18825	22590

Dimensions, Weights, and Parts Lists 1/2"-2" Valves

Flanged Body

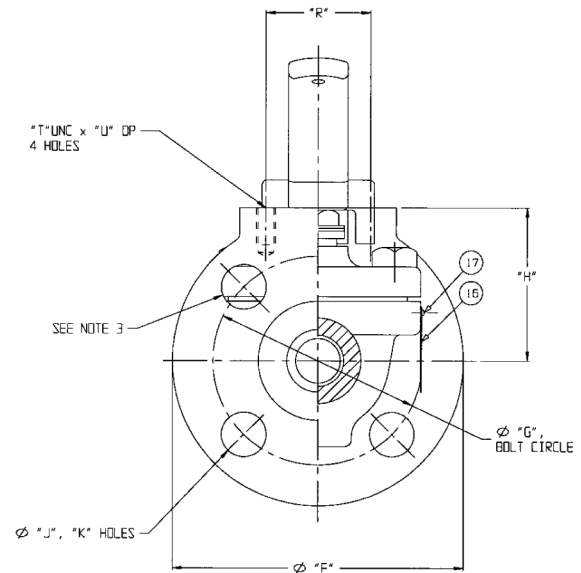
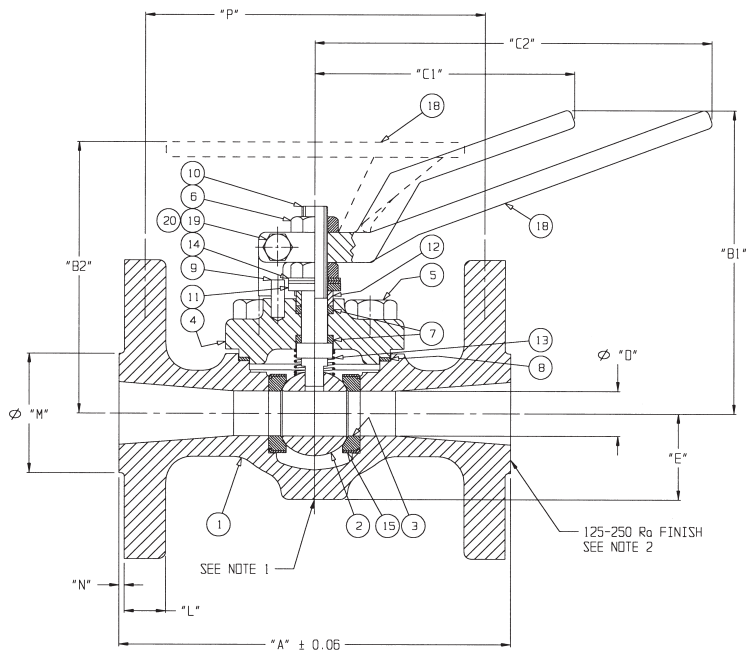

Note

1. Body boss can be drilled, tapped, and plugged.
2. End machining meets ASME B16.5 for flanged ends.
3. 1/2" and 3/4" 150 lb class flanged bolt holes are tapped 1/2" - 13 UNC class 2B. Top two holes are blind drilled and tapped.
4. The design meets ASME B16.34, MSS-SP 72 and ASME B16.10.
5. Valve is shown in the open position. Clockwise rotation of stem closes the valve.

Socket Weld and Threaded Body

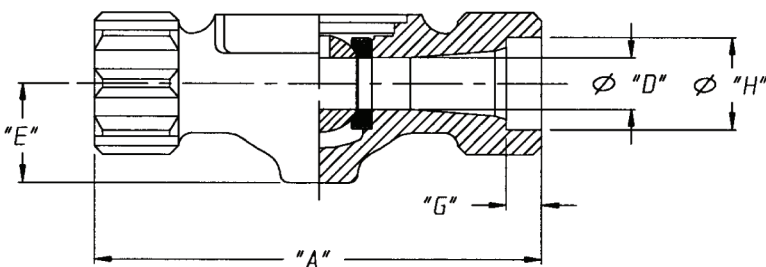

Buttweld Body

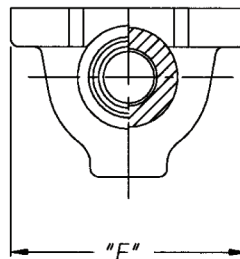
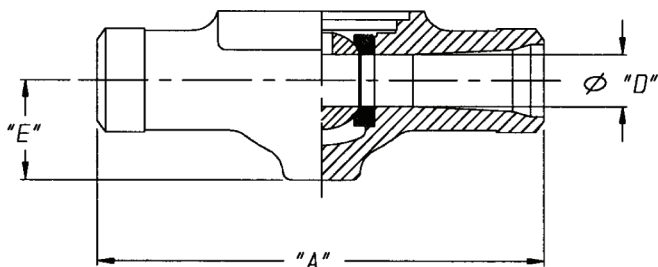

Flanged Body Dimensions in inches and (mm)

VALVE SIZE	PRESSURE CLASS	"A" DIM	"B1" DIM	"B2" DIM	"C1" DIM	"C2" DIM	"D" DIM	"E" DIM	"F" DIM	"G" DIM	"H" DIM	"J" DIM	"K"	"L" DIM	"M" DIM	"N" DIM	"P" DIM	"R" DIM	"T" DIM	"U" DIM	WEIGHT					
																					LBS	KG				
1/2"	150#	4.25 (113.0)							3.50 (88.9)	2.38 (60.4)	1.94 (49.3)	-	4	0.38 (9.6)	1.38 (35.0)	0.06 (1.5)	3.62 (91.9)	2.00 (50.8)	1/4-20 UNC	0.38 (9.6)	6.9	3.1				
	300#	5.50 (139.7)					0.62 (15.7)		3.75 (95.2)	2.62 (66.5)	2.06 (52.3)	0.63 (16.0)		0.50 (12.7)		0.25 (6.4)	4.88 (124.0)							7.9	3.6	
	600#	6.50 (165.1)							3.88 (98.6)	2.75 (69.8)	2.12 (53.8)	-		0.61 (15.5)		0.25 (6.4)	5.38 (136.6)							9.0	4.1	
3/4"	150#	4.62 (117.3)											4	0.41 (10.4)	1.69 (42.9)	0.06 (1.5)	4.00 (101.6)	1.75 (44.4)	5/16-18 UNC	0.62 (15.7)	8.0	3.6				
	300#	6.00 (152.4)	5.10 (129.5)	4.62 (117.3)	4.35 (110.5)	-		1.44 (36.6)		4.62 (117.3)	3.25 (82.6)	2.50 (63.5)		0.75 (19.0)	0.56 (14.2)		0.25 (6.4)				5.31 (134.9)				11.5	5.2
	600#	7.50 (190.5)							4.25 (108.0)	3.12 (79.2)		0.63 (16.0)		0.67 (17.0)		0.25 (6.4)	6.31 (160.3)									
1"	150#	5.00 (127.0)											4	0.41 (10.4)	2.00 (50.8)	0.06 (1.5)	4.19 (106.4)	1.75 (44.4)	5/16-18 UNC	0.62 (15.7)	9.0	4.1				
	300#	6.50 (165.1)							4.88 (124.0)	3.50 (88.9)	2.56 (65.0)	0.75 (19.0)		0.69 (17.5)		0.25 (6.4)	5.69 (144.5)								12.0	5.4
	600#	8.50 (215.9)							5.00 (127.0)	3.88 (98.6)	3.00 (76.2)	0.63 (16.0)		0.74 (18.8)		0.25 (6.4)	7.25 (184.2)								13.0	5.8
1-1/2"	150#	6.50 (165.1)											4	0.56 (14.2)	2.88 (73.2)	0.06 (1.5)	5.62 (142.7)	1.75 (44.4)	5/16-18 UNC	0.62 (15.7)	14.5	6.5				
	300#	7.50 (190.5)	5.65 (143.5)	5.16 (131.1)	5.14 (130.6)	-	1.12 (28.4)	1.72 (43.7)		6.12 (155.4)	4.50 (114.3)	3.31 (84.1)		0.88 (22.4)	0.81 (20.6)		0.25 (6.4)				65.56 (1666.6)				22.0	9.9
	600#	9.50 (241.3)							6.00 (152.4)	4.75 (120.6)	3.12 (79.2)			0.93 (23.6)		0.25 (6.4)	8.00 (203.2)								24.0	10.8
2"	150#	7.00 (177.8)											8	0.62 (15.7)	3.62 (91.9)	0.06 (1.5)	5.19 (132.2)	2.25 (57.2)	5/16-18 UNC	0.62 (15.7)	23.5	10.6				
	300#	8.50 (215.9)	6.60 (167.6)	5.54 (140.7)	-	8.65 (219.7)	1.50 (38.1)	2.06 (52.3)		6.50 (165.1)	5.00 (127.0)	3.75 (95.2)		0.75 (19.0)	0.88 (22.4)		0.25 (6.4)				7.80 (199.5)				30.0	13.5
	600#	11.50 (292.1)												1.05 (26.7)		0.25 (6.4)	9.88 (251.0)								34.0	15.3

Socket Weld and Threaded Body

VALVE SIZE	PRESSURE CLASS	"A" DIM	"B1" DIM	"B2" DIM	"C1" DIM	"C2" DIM	"D" DIM	"E" DIM	"F" DIM	"G" DIM	"H" DIM	WEIGHT		
												LBS	KG	
1/2"	150-500#	5.50 (139.7)					0.62 (15.7) - SOCKETWELD 0.70 (17.8) - THREADED				0.39 (9.9)	0.86 (21.8)	5.7	2.6
3/4"		6.00 (152.4)	5.10 (129.5)	4.62 (117.3)	4.35 (110.5)	-		1.44 (36.6)	3.44 (87.4)	0.51 (13.0)	1.07 (27.2)	5.8	2.6	
1"		6.50 (165.1)						0.75 (19.0)		0.51 (13.0)	1.34 (34.0)	6.5	2.9	
1-1/2"		7.50 (190.5)	5.65 (143.5)	5.16 (131.1)	5.14 (130.6)	-	1.12 (28.4)	1.72 (43.7)	3.81 (96.8)	0.51 (13.0)	1.92 (48.8)	13.0	5.8	
2"		8.50 (215.9)	6.60 (167.6)	5.54 (140.7)	-	8.65 (219.7)	1.50 (38.1)	2.06 (52.3)	4.81 (122.2)	0.63 (16.0)	2.41 (61.2)	18.0	8.1	
		11.50 (292.1)												

Buttweld Body

VALVE SIZE	PRESSURE CLASS	"A" DIM	"B1" DIM	"B2" DIM	"C1" DIM	"C2" DIM	"D" DIM	"E" DIM	"F" DIM	WEIGHT		
										LBS	KG	
1/2"	150-300#	5.50 (139.7)								0.56 (14.2)	5.3	2.4
	600#	6.50 (165.1)									5.7	2.6
3/4"	150-300#	6.00 (152.4)	5.10 (129.5)	4.62 (117.3)	4.35 (110.5)	-		1.44 (36.6)	3.44 (87.4)	0.68 (17.3)	5.5	2.5
	600#	7.50 (190.5)								0.62 (15.7)	7.0	3.2
1"	150-300#	6.50 (165.1)								0.75 (19.0)	6.0	2.7
	600#	8.50 (215.9)									6.5	2.9
1-1/2"	150-300#	7.50 (190.5)	5.65 (143.5)	5.16 (131.1)	5.14 (130.5)	-	1.12 (28.4)	1.72 (43.7)	3.81 (96.8)		13.0	5.8
	600#	9.50 (241.3)									14.0	6.3
2"	150-300#	8.50 (215.9)	6.50 (167.6)	5.54 (140.7)	-	8.65 (219.7)	1.50 (38.1)	2.06 (52.3)	4.81 (122.2)		17.0	7.6
	600#	11.50 (292.1)									18.5	8.3

Bill of Materials - Base Valve with Standard Cover

ITEM	QTY	DESCRIPTION	CARBON STEEL	STAINLESS STEEL	ALLOY 20	HASTELLOY
1	1	Body	CS ASTM A216 GR WCB ▲	SS ASTM A351 GR CF8M	SS ASTM A351 GR CN7M	HAST ASTM A494 CW6M
2	1	Ball	SS ASTM A276 TYPE 316 ▲	SS ASTM A276 TYPE 316	SS ASTM B473 N08020	HAST ASTM B574 10276
* 3	2	Seat	PTFE	PTFE	PTFE	PTFE
4	1	Cover	CS ASTM A216 GR WCB	SS ASTM A351 GR CF8M	SS ASTM A351 GR CN7M	HAST ASTM A494 CW6M
5	4	Screw, Hex HD.Cap	CS ASTM A193 GR B7	SS ASTM A193 GR B8	SS ASTM A193 GR B8	SS ASTM A193 GR B8
6	2	Nut, Hex Jam	CS	CS	CS	CS
* 7	2	Seal, Stem	PTFE	PTFE	PTFE	PTFE
* 8	1	Gasket	PTFE	PTFE	PTFE	PTFE
9	1	Pin, Grooved	SS	SS	SS	SS
10	1	Stem	SS ASTM A276 TYPE 316	SS ASTM A276 TYPE 316	SS ASTM B473 N08020	HAST ASTM B574 10276
11	1	Washer, Flat	CS ASTM A659 GR1018	CS ASTM A659 GR1018	CS ASTM A659 GR1018	CS ASTM A659 GR1018
12	1	Ring, Gland	SS ASTM A276 TYPE 316	SS ASTM A276 TYPE 316	SS ASTM A276 TYPE 316	SS ASTM A276 TYPE 316
13	1	Spring	SS ASTM A313 TYPE 316	SS ASTM A313 TYPE 316	INCONEL ASTM B637, X750	INCONEL ASTM B637, X750
14	2	Washer, Belleville	CS ASTM A684	CS ASTM A684	CS ASTM A684	CS ASTM A684
* 15	2	Ring, Seat	SS ASTM A240 TYPE 316	SS ASTM A240 TYPE 316	ALLOY 20 ASTM B463 N08020	HAST ASTM B574 10276
16	1	Plate, Ident.	SS ASTM A240 TYPE 304	SS ASTM A240 TYPE 304	SS ASTM A240 TYPE 304	SS ASTM A240 TYPE 304
17	2	Screw, Drive	CS	CS	CS	CS
18	1	Handle	CS ASTM A216 GR WCB	CS ASTM A216 GR WCB	CS ASTM A216 GR WCB	CS ASTM A216 GR WCB
19	1	Screw, Hex HD.Cap	STEEL	STEEL	STEEL	STEEL
20	1	Nut, Hex	STEEL	STEEL	STEEL	STEEL

- - Buttweld, socketweld and threaded bodies are ASTM A351-CF3M
- ◆ - Buttweld, socketweld and threaded bodies are ASTM A494-CW2M
- ◆ - Refer to the "Ordering Information" section of this catalog for specific seat/seal combinations
- * - Extended covers have three stem seals
- * - Recommended spare parts. Available as seat/seal kit
- ▲ - Zinc phosphate coated

Note: See pages 49-50 for optional materials.

Flanged Body Dimensions in inches and (mm)

VALVE SIZE	PRESSURE CLASS	"A" DIM	"B" DIM	"C" DIM	"D" DIM	"E" DIM	"F" DIM	"G" DIM	"H" DIM	"J" DIM	"K"	"L" DIM	"M" DIM	"N" DIM	"P" DIM	"R" DIM	"T" DIM	"U" DIM	WEIGHT		
																			LBS	KG	
3"	150#	8.00 (203.2)	8.00 (203.2)	15.12 (384.0)	2.25 (57.2)	2.88 (73.2)	7.50 (190.5)	6.00 (152.4)	4.00 (101.6)	0.75 (19.0)	4	0.75 (19.0)	5.00 (127.0)	0.06 (1.5)	7.12 (180.8)	3.50 (88.9)	3/8-16 UNC	0.75 (19.0)	41.0	18.4	
	300#	11.12 (282.4)					8.25 (209.6)	6.62 (168.1)	4.50 (114.3)	0.88 (22.4)		1.12 (28.4)		9.88 (251.0)	64.0				28.8		
	600#	14.00 (355.6)					9.00 (228.6)	7.50 (190.5)	4.88 (124.0)	0.75 (19.0)		1.32 (33.5)		0.25 (6.4)	12.12 (307.6)				77.0	34.6	
4"	150#	9.00 (228.6)	9.00 (228.6)	15.12 (384.0)	3.00 (76.2)	3.38 (85.8)	9.00 (228.6)	7.50 (190.5)	4.88 (124.0)	0.75 (19.0)	8	0.94 (23.9)	6.19 (157.2)	0.06 (1.5)	8.00 (203.2)	4.00 (101.6)	7/16-14 UNC	1.00 (25.4)	0.88 (22.4)	54.0	24.3
	300#	12.00 (304.8)					10.00 (254.0)	7.88 (200.2)	5.62 (142.7)	0.88 (22.4)		1.25 (31.8)		10.69 (271.5)	102.0				45.9		
	600#	17.00 (431.8)					10.75 (273.0)	8.50 (215.9)	1.00 (25.4)	1.56 (39.6)		0.25 (6.4)		14.88 (378.0)	145.0				65.7		
6"	150#	15.50 (393.7)	12.51 (317.8)	21.37 (542.8)	4.00 (101.6)	4.56 (115.8)	11.00 (279.4)	9.50 (241.3)	6.50 (165.1)	0.88 (22.4)	12	1.00 (25.4)	8.50 (215.9)	0.06 (1.5)	14.38 (365.2)	4.00 (101.6)	0.75 (19.0)	198.4	89.3		
	300#	15.88 (403.4)					12.50 (317.5)	10.62 (269.7)	7.12 (180.8)	1.44 (36.6)		0.06 (1.5)		14.38 (365.2)	235.0			105.8			

Socket Weld and Threaded Body

VALVE SIZE	PRESSURE CLASS	"A" DIM	"B" DIM	"C" DIM	"D" DIM	"E" DIM	"F" DIM	"G" DIM	"H" DIM	WEIGHT	
										LBS	KG
3"	150-300#	11.12 (282.4)	8.00 (203.2)	15.12 (384.0)	2.25 (57.2)	2.88 (73.2)	7.50 (190.5)	0.63 (16.0)	3.54 (89.9)	42.0	18.9

Buttweld Body

VALVE SIZE	PRESSURE CLASS	"A" DIM	"B" DIM	"C" DIM	"D" DIM	"E" DIM	"F" DIM	WEIGHT	
								LBS	KG
3"	150-300#	11.12 (282.4)	8.00 (203.2)	15.12 (384.0)	2.25 (57.2)	2.88 (73.2)	7.50 (190.5)	39.0	17.5
	600#	14.00 (355.6)					47.0	21.2	
4"	150-300#	12.00 (304.8)	9.00 (228.6)	15.12 (384.0)	3.00 (76.2)	3.38 (85.8)	8.38 (212.8)	61.0	27.4
	600#	17.00 (431.8)					80.0	36.0	
6"	150-300#	15.88 (403.4)	12.51 (317.8)	21.37 (542.8)	4.00 (101.6)	4.56 (115.8)	12.10 (307.3)	164.6	74.1

Bill of Materials - Base Valve with Standard Cover

ITEM	QTY	DESCRIPTION	CARBON STEEL	STAINLESS STEEL	ALLOY 20	HASTELLOY
1	1	Body	CS ASTM A216 GR WCB ▲	SS ASTM A351 GR CF8M	ALLOY 20 ASTM A351 GR CN7M	HAST ASTM A494 CW6M ◆
2	1	Ball	SS ASTM A351 CF8M	SS ASTM A351 CF8M	ALLOY 20 ASTM A351 CN7M	HAST ASTM B574 10276
* 3	2	Seat ◆	PTFE	PTFE	PTFE	PTFE
4	1	Cover	CS ASTM A216 GR WCB ▲	SS ASTM A351 GR CF8M	ALLOY 20 ASTM A351 GR CN7M	HAST ASTM A494 CW6M
5	Ω 8	Screw, Hex HD.Cap	CS ASTM A193 GR B7	SS ASTM A193 GR B8	SS ASTM A193 GR B8	SS ASTM A193 GR B8
6	1	Nut, Hex Jam	CS	SS	SS	SS
* 7	✕ 2	Seal, Stem ◆	PTFE	PTFE	PTFE	PTFE
* 8	1	Gasket ◆	PTFE	PTFE	PTFE	PTFE
9	1	Pin, Grooved	SS	SS	SS	SS
10	1	Stem	SS ASTM A276 TYPE 316	SS ASTM A276 TYPE 316	ALLOY 20 ASTM B473 N08020	HAST ASTM B574 10276
11	1	Rotational Stop	CS ASTM A216 GR WCB	CS ASTM A216 GR WCB	CS ASTM A216 GR WCB	CS ASTM A216 GR WCB
12	1	Ring, Gland	SS ASTM A276 TYPE 316	SS ASTM A276 TYPE 316	SS ASTM A276 TYPE 316	SS ASTM A276 TYPE 316
13	1	Spring	SS ASTM A313 TYPE 316	SS ASTM A313 TYPE 316	INCONEL ASTM B637, X750	INCONEL ASTM B637, X750
14	2	Washer, Belleville	CS ASTM A684	17-7PH	17-7PH	17-7PH
* 15	2	Ring, Seat	SS ASTM A240 TYPE 316	SS ASTM A240 TYPE 316	ALLOY 20 ASTM B463 N08020	HAST ASTM B574 10276
16	1	Plate, Ident.	SS ASTM A240 TYPE 304	SS ASTM A240 TYPE 304	SS ASTM A240 TYPE 304	SS ASTM A240 TYPE 304
17	2	Screw, Drive	CS	CS	CS	CS
18	1	Handle	CS ASTM A-53	CS ASTM A-53	CS ASTM A-53	CS ASTM A-53
19	1	Screw, Hex HD.Cap	STEEL	SS	SS	SS
20	1	Screw, Soc.HD.Set	STEEL	STEEL	STEEL	STEEL
21	1	Circle, Cotter	STEEL	STEEL	STEEL	STEEL
22	1	Hub, Lever	CS ASTM A216 GR WCB ▲	CS ASTM A216 GR WCB ▲	CS ASTM A216 GR WCB ▲	CS ASTM A216 GR WCB ▲
23	1	Grip, Handle	PLASTIC	PLASTIC	PLASTIC	PLASTIC
24	2	Screw, Flat HD.MACH.	STEEL	STEEL	STEEL	STEEL
25	1	Plate, Locking	CS ASTM A108-1018	CS ASTM A108-1018	CS ASTM A108-1018	CS ASTM A108-1018

- - Buttweld, socketweld and threaded bodies are ASTM A351-CF3M
- ◆ - Buttweld, socketweld and threaded bodies are ASTM A494-CW2M
- ◆ - Refer to the "Ordering Information" section of this catalog for specific seat/seal combinations
- ✕ - Extended covers have three stem seals
- Ω - 3" and 4" Class 150 flanged valves have four cap screws
- * - Recommended spare parts. Available as seat/seal kit
- ▲ - Zinc phosphate coated

Note: See pages 49-50 for optional materials.

Actuator Mounting Dimensions

Flange Pads

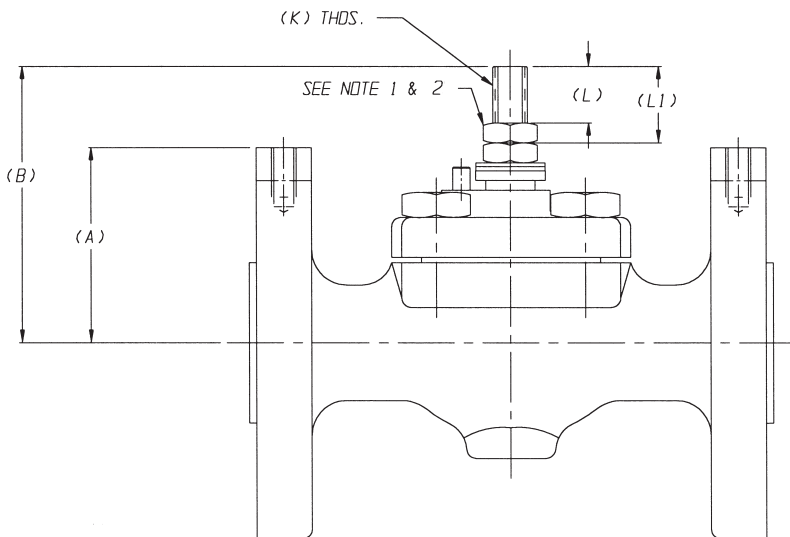
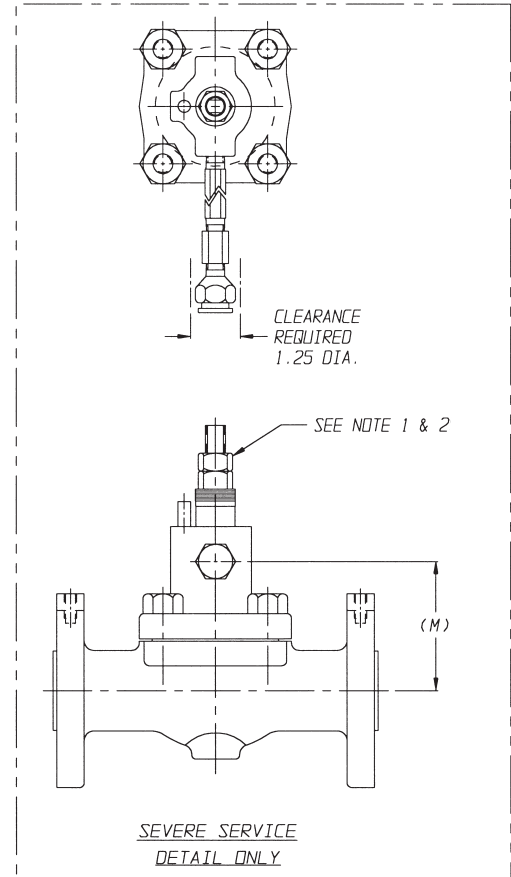
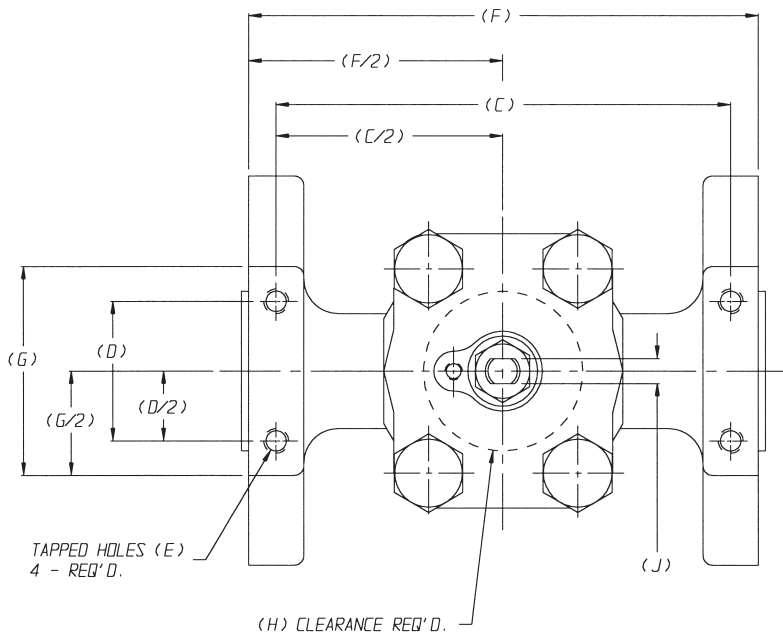

Note

1. Double nuts on actuated valves .5"-2" sizes only.
2. Single nut is used with stem extension kits for all sizes.

VALVE SIZE	PRESS. CLASS	COVER TYPE	(A)	(B)	(C)	(D)	(E)	(F)	(G)	(H)	(J)	(K)	(L)	(L1)	(M)					
1/2"	150#	STANDARD	1.94	3.47	3.62	2.00	0.25-20UNC x 0.38 DP.	4.12	2.62	2.00	0.309 0.305	0.438-14UNC	0.58	0.83	-					
		EXTENDED		4.97						2.31			1.19	0.94	2.78					
		SEVERE SERV.		5.34						2.00			0.58	0.83	-					
	300#	STANDARD	2.06	3.47	4.88			5.38		2.31			2.00	0.58	0.83	-				
		EXTENDED		4.97				2.31		1.19			0.94	2.78						
		SEVERE SERV.		5.34				2.00		0.58			0.83	-						
	600#	STANDARD	2.50	3.47	5.38			6.00		2.31			2.00	0.58	0.83	-				
		EXTENDED		4.97				2.31		1.19			0.94	2.78						
		SEVERE SERV.		5.34				2.00		0.58			0.83	-						
3/4"	150#	STANDARD	2.12	3.47	4.00	1.75	0.312-18UNC x .47/.56 DEEP	4.50	3.12	2.00	0.372 0.368	0.50-13UNC	0.58	0.83	-					
		EXTENDED		4.97						2.31			1.19	0.94	2.78					
		SEVERE SERV.		5.34						2.00			0.58	0.83	-					
	300#	STANDARD	2.50	3.47	5.31			5.88		2.31			2.00	0.58	0.83	-				
		EXTENDED		4.97				2.31		1.19			0.94	2.78						
		SEVERE SERV.		5.34				2.00		0.58			0.83	-						
	600#	STANDARD	2.56	3.47	7.25			8.00		2.31			2.00	0.58	0.83	-				
		EXTENDED		4.97				2.31		1.19			0.94	2.78						
		SEVERE SERV.		5.34				2.00		0.58			0.83	-						
1 1/2"	150#	STANDARD	3.00	4.10	5.62	1.75	0.312-18UNC x .47/.56 DEEP	6.38	3.12	2.00	0.372 0.368	0.50-13UNC	0.60	0.91	-					
		EXTENDED		5.85						3.19			0.78	1.09	3.32					
		SEVERE SERV.		6.35						2.00			0.60	0.91	-					
	300#	STANDARD	3.31	4.10	6.56			7.38		3.19			2.00	0.60	0.91	-				
		EXTENDED		5.85				3.19		0.78			1.09	3.32						
		SEVERE SERV.		6.35				2.00		0.60			0.91	-						
	600#	STANDARD	3.31	4.10	8.00			9.00		3.19			2.00	0.60	0.91	-				
		EXTENDED		5.85				3.19		0.78			1.09	3.32						
		SEVERE SERV.		6.35				2.00		0.60			0.91	-						
2"	150#	STANDARD	3.12	4.87	6.19	2.25	0.375-16UNC x 0.75 DP.	6.88	4.62	2.50	0.622 0.618	1.00-8UNC	0.97	1.34	-					
		EXTENDED		6.87						3.38			0.93	1.30	3.81					
		SEVERE SERV.		7.19						2.50			0.97	1.34	-					
	300#	STANDARD	3.75	4.87	7.50			8.38		3.38			2.50	0.97	1.34	-				
		EXTENDED		6.87				3.38		0.93			1.30	3.81						
		SEVERE SERV.		7.19				2.50		0.97			1.34	-						
	600#	STANDARD	3.75	4.87	9.88			11.00		3.38			2.50	0.97	1.34	-				
		EXTENDED		6.87				3.38		0.93			1.30	3.81						
		SEVERE SERV.		7.19				2.50		0.97			1.34	-						
3"	150#	STANDARD	4.00	5.89	7.12	3.50	0.375-16UNC x 0.75 DP.	7.88	4.62	3.00	0.622 0.618	1.00-8UNC	0.90	-	-					
		EXTENDED		8.14						4.50			1.09	5.03						
		SEVERE SERV.		9.22						3.00			0.90	-	-					
	300#	STANDARD	4.50	5.89	9.88			11.00		4.50			3.00	0.90	-	-				
		EXTENDED		8.14				4.50		1.09			5.03							
		SEVERE SERV.		9.22				3.00		0.90			-	-						
	600#	STANDARD	4.50	5.89	12.12			13.50		4.50			3.00	0.90	-	-				
		EXTENDED		8.14				4.50		1.09			5.03							
		SEVERE SERV.		9.22				3.00		0.90			-	-						
4"	150#	STANDARD	4.88	7.11	8.00	4.00	0.438-14UNC x 0.88 DP.	8.88	5.00	3.50	0.747 0.743	1.25-7UNC	1.10	-	-					
		EXTENDED		9.48						5.31			1.08	5.97						
		SEVERE SERV.		10.41						3.50			1.10	-	-					
	300#	STANDARD	5.62	7.05	10.59			11.88		5.31			3.50	1.10	-	-				
		EXTENDED		9.43				5.31		1.08			5.91							
		SEVERE SERV.		10.41				3.50		1.10			-	-						
	600#	STANDARD	5.62	7.05	14.88			16.50		5.31			3.50	1.10	-	-				
		EXTENDED		9.43				5.31		1.08			5.91							
		SEVERE SERV.		10.41				3.50		1.10			-	-						
6"	150#	STANDARD	6.50	10.20	14.38	4.00	0.438-14UNC x 0.75 DP.	15.32	5.25	6.00	1.247 1.243	2.00-12UNC	1.69	-	-					
		EXTENDED		13.45									1.30	6.68						
		SEVERE SERV.		10.20									1.69	-	-					
	300#	STANDARD	7.12	10.20	14.38			15.70		13.45			6.00	1.30	6.68					
		EXTENDED		13.45				1.69		-			-							
		SEVERE SERV.		10.20				1.30		6.68										
	-	-	-	-	-			-		-			-	-	-	-	-	-	-	-

Actuator Mounting Dimensions

Bonnet Studs and Double Nuts

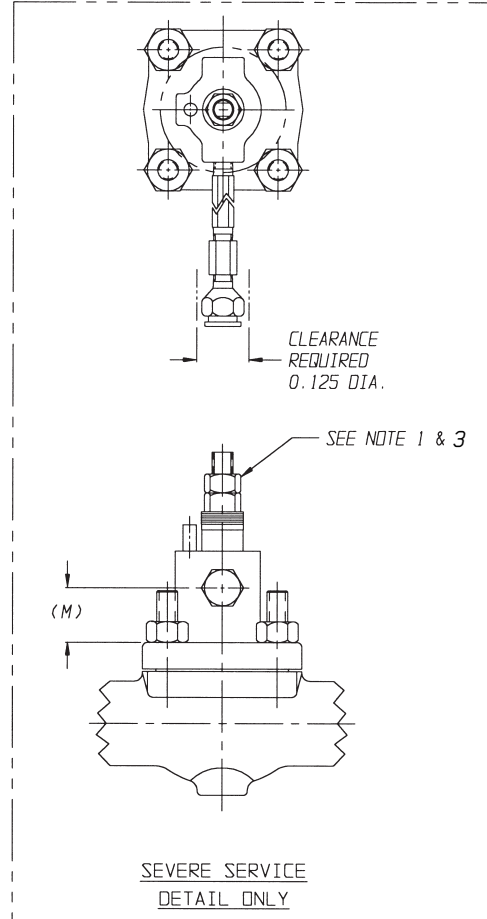
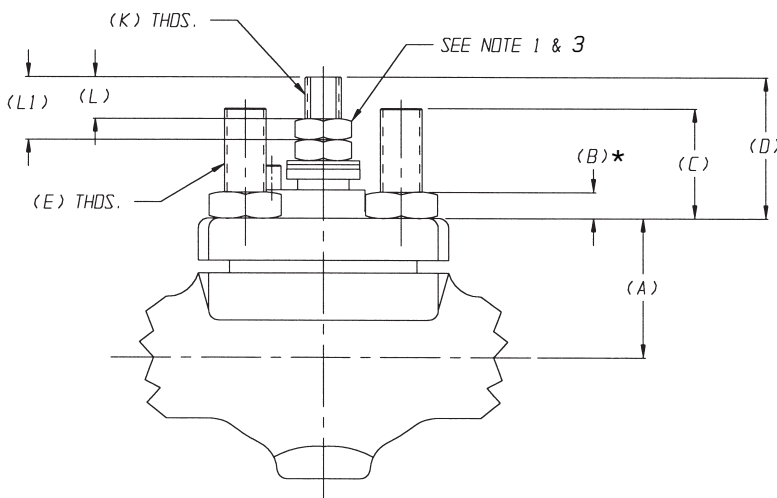
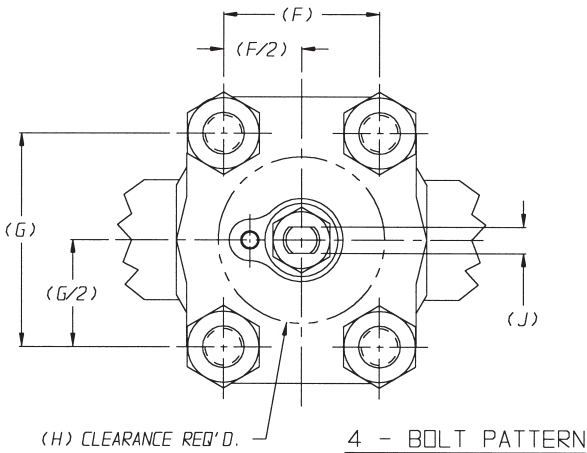
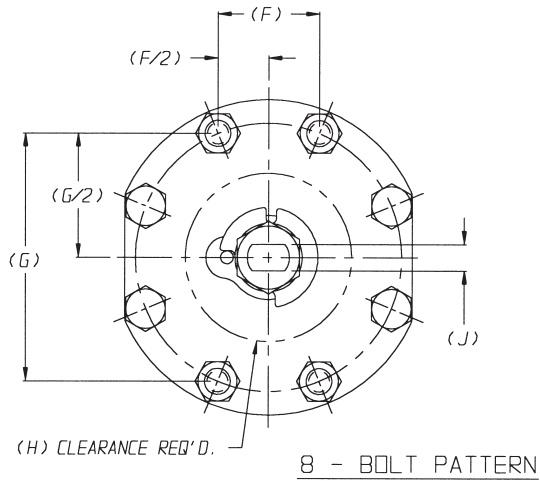

Note

1. Double nuts on actuated valves .5"-2" sizes only.
- * 2. Indicates dimensions for finished hex nuts.
3. Single nut is used with stem extension kits for all sizes.

VALVE SIZE	PRESS. CLASS	COVER TYPE	(A)	(B)	(C)	(D)	(E)	(F)	(G)	(H)	(J)	(K)	(L)	(L1)	(M)
1/2"	150# (4 BOLT)	STANDARD	1.56	0.448 0.427	1.31	1.91	0.50-13UNC	1.875	2.562	2.00	0.309 0.305	0.438-14UNC	0.58	0.83	-
		EXTENDED				3.41				2.31			1.19	0.94	1.22
		SEVERE SERV.				3.79				2.31			0.58	0.83	-
	300# (4 BOLT)	STANDARD				1.91				2.00			1.19	0.94	1.22
		EXTENDED				3.41				2.31			0.58	0.83	-
		SEVERE SERV.				3.79				2.31			1.19	0.94	1.22
	600# (4 BOLT)	STANDARD				1.91				2.00			0.58	0.83	-
		EXTENDED				3.41				2.31			1.19	0.94	1.22
		SEVERE SERV.				3.79				2.31			0.58	0.83	-
3/4"	150# (4 BOLT)	STANDARD	1.56	0.448 0.427	1.31	1.91	0.50-13UNC	1.875	2.562	2.00	0.309 0.305	0.438-14UNC	0.58	0.83	-
		EXTENDED				3.41				2.31			1.19	0.94	1.22
		SEVERE SERV.				3.79				2.31			0.58	0.83	-
	300# (4 BOLT)	STANDARD				1.91				2.00			1.19	0.94	1.22
		EXTENDED				3.41				2.31			0.58	0.83	-
		SEVERE SERV.				3.79				2.31			1.19	0.94	1.22
	600# (4 BOLT)	STANDARD				1.91				2.00			0.58	0.83	-
		EXTENDED				3.41				2.31			1.19	0.94	1.22
		SEVERE SERV.				3.79				2.31			0.58	0.83	-
1"	150# (4 BOLT)	STANDARD	1.56	0.448 0.427	1.31	1.91	0.50-13UNC	1.875	2.562	2.00	0.309 0.305	0.438-14UNC	0.58	0.83	-
		EXTENDED				3.41				2.31			1.19	0.94	1.22
		SEVERE SERV.				3.79				2.31			0.58	0.83	-
	300# (4 BOLT)	STANDARD				1.91				2.00			1.19	0.94	1.22
		EXTENDED				3.41				2.31			0.58	0.83	-
		SEVERE SERV.				3.79				2.31			1.19	0.94	1.22
	600# (4 BOLT)	STANDARD				1.91				2.00			0.58	0.83	-
		EXTENDED				3.41				2.31			1.19	0.94	1.22
		SEVERE SERV.				3.79				2.31			0.58	0.83	-
1 1/2"	150# (4 BOLT)	STANDARD	1.94	0.559 0.535	1.44	2.16	0.625-11UNC	2.625	2.875	2.00	0.622 0.618	0.50-13UNC	0.60	0.91	-
		EXTENDED				3.91				3.19			0.78	1.09	1.38
		SEVERE SERV.				4.41				3.19			0.60	0.91	-
	300# (4 BOLT)	STANDARD				2.16				2.00			0.78	1.09	1.38
		EXTENDED				3.91				3.19			0.60	0.91	-
		SEVERE SERV.				4.41				3.19			0.78	1.09	1.38
	600# (4 BOLT)	STANDARD				2.16				2.00			0.60	0.91	-
		EXTENDED				3.91				3.19			0.78	1.09	1.38
		SEVERE SERV.				4.41				3.19			0.60	0.91	-
2"	150# (4 BOLT)	STANDARD	2.31	0.559 0.535	1.62	2.56	0.625-11UNC	2.875	3.625	2.50	0.747 0.743	0.625-11UNC	0.97	1.34	-
		EXTENDED				4.56				3.38			0.93	1.30	1.50
		SEVERE SERV.				4.88				3.38			0.97	1.34	-
	300# (4 BOLT)	STANDARD				2.56				2.50			0.93	1.30	1.50
		EXTENDED				4.56				3.38			0.97	1.34	-
		SEVERE SERV.				4.88				3.38			0.97	1.34	-
	600# (4 BOLT)	STANDARD				2.56				2.50			0.97	1.34	-
		EXTENDED				4.56				3.38			0.93	1.30	1.50
		SEVERE SERV.				4.88				3.38			0.97	1.34	-
3"	150#FLGO (4 BOLT)	STANDARD	2.84	0.559 0.535	2.16	3.05	0.625-11UNC	4.125	4.75	3.00	0.622 0.618	1.00-8UNC	0.90	-	-
		EXTENDED				5.30				4.50			1.09	2.19	-
		SEVERE SERV.				6.39				4.50			0.90	-	-
	150/300# (8 BOLT)	STANDARD				2.61				3.00			1.09	1.75	-
		EXTENDED				4.86				4.50			0.90	-	-
		SEVERE SERV.				5.94				4.50			1.09	1.75	-
	600# (8 BOLT)	STANDARD				2.61				3.00			0.90	-	-
		EXTENDED				4.86				4.50			1.09	1.75	-
		SEVERE SERV.				5.94				4.50			0.90	-	-
4"	150#FLGO (4 BOLT)	STANDARD	3.35	0.565 0.617	2.34	3.77	0.75-10UNC	2.822	6.814	3.50	0.747 0.743	1.25-7UNC	1.10	-	-
		EXTENDED				6.15				5.31			1.08	2.00	-
		SEVERE SERV.				7.08				5.31			1.10	-	-
	150/300# (8 BOLT)	STANDARD				3.14				3.50			1.08	2.00	-
		EXTENDED				5.52				5.31			1.10	-	-
		SEVERE SERV.				6.44				5.31			1.10	-	-
	600# (8 BOLT)	STANDARD				3.14				3.50			1.08	2.00	-
		EXTENDED				5.52				5.31			1.10	-	-
		SEVERE SERV.				6.44				5.31			1.08	2.00	-
6"	150# (8 BOLT)	STANDARD	4.75	1.012 0.956	3.00	5.45	1.00-8UNC	3.895	9.404	6.00	1.247 1.243	2.00-12UNC	1.69	-	-
		EXTENDED				8.65				-			1.30	2.39	-
		SEVERE SERV.				8.65				-			1.69	-	-
	300# (8 BOLT)	STANDARD				5.45				-			1.30	2.39	-
		EXTENDED				8.65				-			1.69	-	-
		SEVERE SERV.				8.65				-			1.30	2.39	-
	-	-				-				-			-	-	-
		-				-				-			-	-	-
		-				-				-			-	-	-

GV Series: Dimensions & Weights

1/2"-2" Valves

Flanged Body

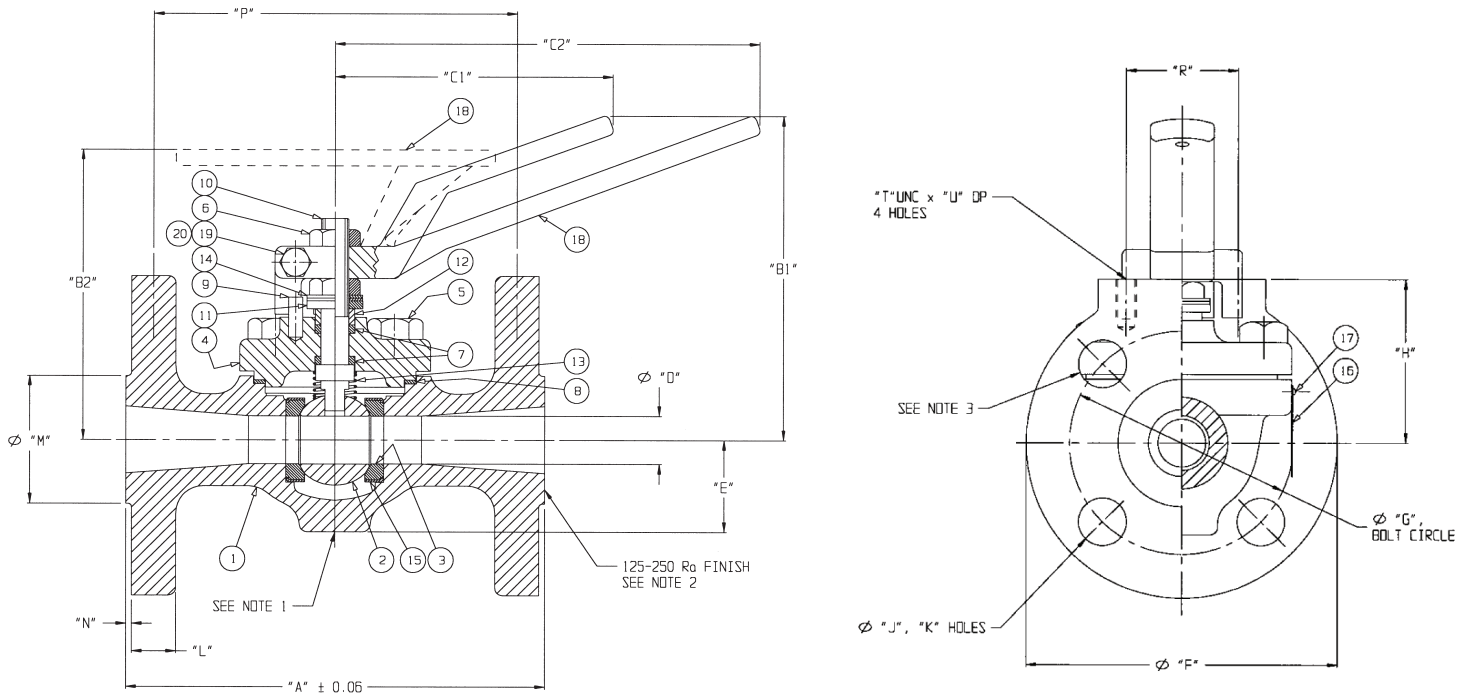

Note

1. Body boss can be drilled, tapped, and plugged.
2. End machining meets ASME B16.5 for flanged ends.
3. 1/2" and 3/4" 150 lb class flanged bolt holes are tapped 1/2" - 13 UNC class 2B. Top two holes are blind drilled and tapped.
4. The design meets ASME B16.34, MSS-SP 72 and ASME B16.10.
5. Valve is shown in the open position. Clockwise rotation of stem closes the valve.

Flanged Body Dimensions in inches and (mm)

PORT	VALVE SIZE	PRESSURE CLASS	"A"	"B1"	"B2"	"C1"	"C2"	"D"	"E"	"F"	"G"	"H"	"J"	"K"	"L"	"M"	"N"	"P"	"R"	"T"	"U"	WEIGHT	
			DIM	DIM	DIM	DIM	DIM	DIM	DIM	DIM	DIM	DIM	DIM		DIM	DIM	DIM	DIM	DIM	DIM	DIM	DIM	LBS
Full Port	1/2"	150#	4.25 (113.0)	5.10 (129.5)	4.62 (117.3)	4.35 (110.5)	-	0.62 (15.7)	1.44 (36.6)	3.50 (88.9)	2.38 (60.4)	1.94 (49.3)	-	4	0.38 (9.6)	1.38 (35.0)	0.06 (1.5)	3.62 (91.9)	2.00 (50.8)	1/4-20 UNC	0.38 (9.6)	6.9	3.1
		300#	6.00 (152.4)							3.75 (95.2)	2.62 (66.5)	2.06 (52.3)	0.63 (16.0)		0.50 (12.7)		5.38 (136.7)	8.1				3.7	
		600#	6.50 (165.1)							4.25 (108.0)	3.12 (79.2)	2.56 (65.0)	0.63 (16.0)		0.61 (15.5)		5.38 (136.6)	9.0				4.1	
Full Port	3/4"	150#	4.62 (117.3)	5.10 (129.5)	4.62 (117.3)	4.35 (110.5)	-	0.75 (19.0)	1.44 (36.6)	3.88 (98.6)	2.75 (69.8)	2.12 (53.8)	-	4	0.41 (10.4)	1.69 (42.9)	0.06 (1.5)	4.00 (101.6)	2.00 (50.8)	1/4-20 UNC	0.38 (9.6)	8.0	3.6
		300#	7.00 (177.8)							4.62 (117.3)	3.25 (82.6)	2.50 (63.5)	0.75 (19.0)		0.56 (14.2)		6.31 (160.3)	8.3				3.8	
		600#	7.50 (190.5)							4.25 (108.0)	3.12 (79.2)	2.56 (65.0)	0.75 (19.0)		0.67 (17.0)		6.31 (160.3)	11.5				5.2	
Regular Port	1"	150#	5.00 (127.0)	5.65 (143.5)	5.16 (131.1)	5.14 (130.6)	-	1.12 (28.4)	1.72 (43.7)	4.25 (108.0)	3.12 (79.2)	2.56 (65.0)	0.63 (16.0)	4	0.41 (10.4)	2.00 (50.8)	0.06 (1.5)	4.19 (106.4)	1.75 (44.4)	5/16-18 UNC	0.62 (15.7)	9.0	4.1
		300#	8.00 (203.2)							4.25 (108.0)	3.12 (79.2)	2.56 (65.0)	0.75 (19.0)		0.69 (17.5)		7.19 (182.6)	12.5				5.7	
		600#	8.50 (215.9)							4.62 (117.3)	3.25 (82.6)	2.50 (63.5)	0.75 (19.0)		0.74 (18.8)		7.25 (184.2)	13.0				5.8	
Regular Port	1-1/2"	150#	6.50 (165.1)	5.65 (143.5)	5.16 (131.1)	5.14 (130.6)	-	1.12 (28.4)	1.72 (43.7)	5.00 (127.0)	3.88 (98.6)	3.00 (76.2)	0.63 (16.0)	4	0.56 (14.2)	2.88 (73.2)	0.06 (1.5)	5.62 (142.7)	1.75 (44.4)	5/16-18 UNC	0.62 (15.7)	14.5	6.5
		300#	9.00 (228.6)							5.00 (127.0)	3.88 (98.6)	3.00 (76.2)	0.88 (22.4)		0.81 (20.6)		8.06 (204.7)	22.0				9.9	
		600#	9.50 (241.3)							4.62 (117.3)	3.25 (82.6)	2.50 (63.5)	0.88 (22.4)		0.93 (23.6)		8.00 (203.2)	23.0				10.4	
Regular Port	2"	150#	8.00 (203.2)	6.60 (167.6)	5.54 (140.7)	-	8.65 (219.7)	1.50 (38.1)	2.06 (52.3)	6.00 (152.4)	4.75 (120.6)	3.12 (79.2)	0.75 (19.0)	8	0.62 (15.7)	3.62 (91.9)	0.06 (1.5)	7.19 (182.6)	2.25 (57.2)	5/16-18 UNC	0.62 (15.7)	24.4	11.1
		300#	10 (266.7)							6.00 (152.4)	4.75 (120.6)	3.12 (79.2)	0.75 (19.0)		0.88 (22.4)		9.5 (241.3)	31.8				14.4	
		600#	11.50 (292.1)							4.62 (117.3)	3.25 (82.6)	2.50 (63.5)	0.75 (19.0)		1.05 (26.7)		9.88 (251.0)	34.0				15.3	

GV Series: Dimensions & Weights

3", 4" and 6" Valves

Flanged Body

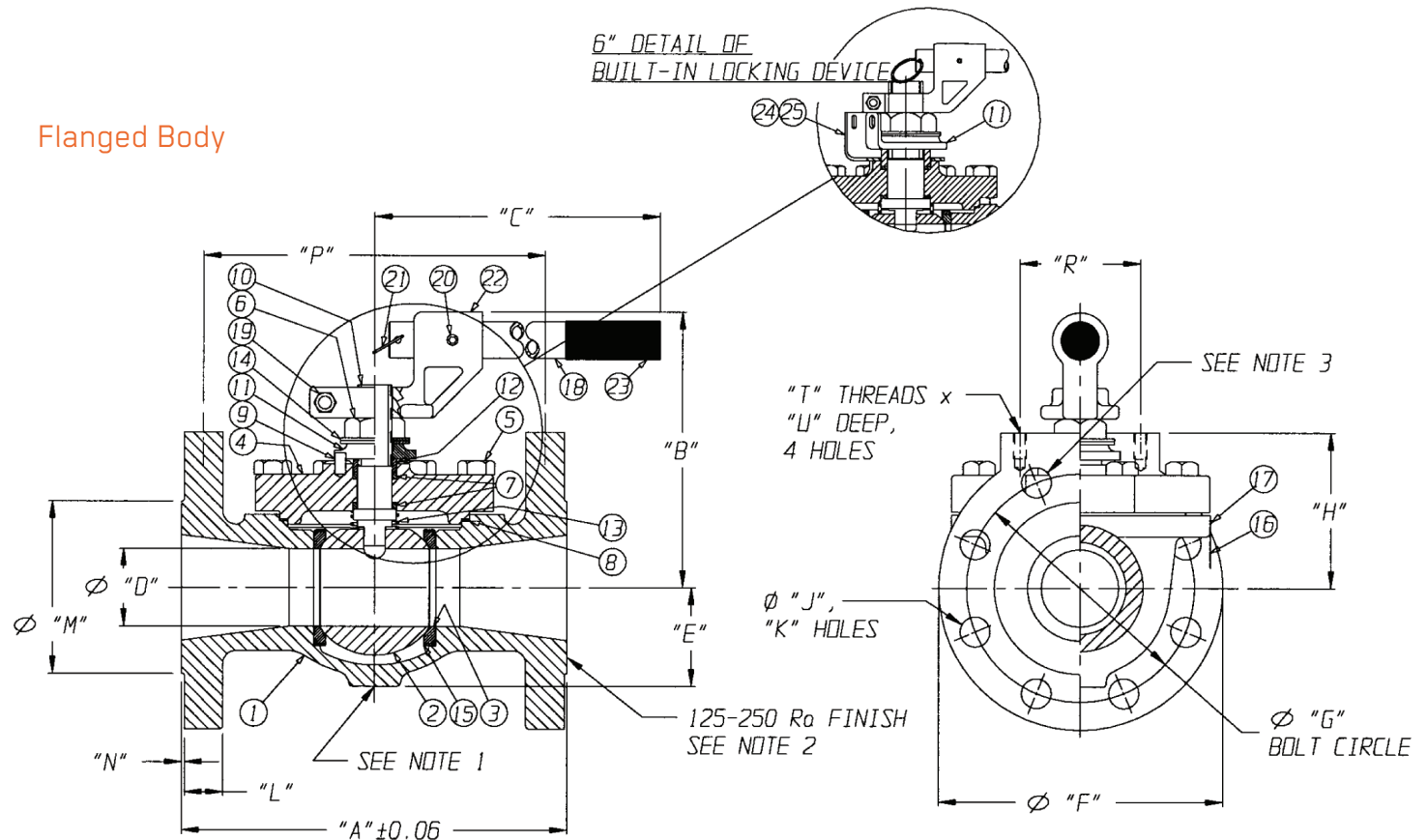

Note

1. Body boss can be drilled, tapped, and plugged.
2. End machining meets ASME B16.5 for flanged ends.
3. Top two flanged bolt holes on 3" and 4" 150 lb class valves are drilled and tapped $\frac{5}{8}$ " - 11 UNC class 2B. Top two flanged bolt holes on 4" 300# Class valves are drilled and tapped $\frac{3}{4}$ "-10 UNC class 2B.
4. The design meets ASME B16.34, MSS-SP 72 and ASME B16.10.
5. Valve is shown in the open position. Clockwise rotation of stem closes the valve.

Flanged Body Dimensions in inches and (mm)

PORT	VALVE SIZE	PRESSURE CLASS	"A" DIM	"B" DIM	"C" DIM	"D" DIM	"E" DIM	"F" DIM	"G" DIM	"H" DIM	"J" DIM	"K"	"L" DIM	"M" DIM	"N" DIM	"P" DIM	"R" DIM	"T" DIM	"U" DIM	WEIGHT	
																				LBS	KG
Regular Port	3"	150#	9.50 (241.3)	8.00 (203.2)	15.12 (384.0)	2.25 (57.2)	2.88 (73.2)	7.50 (190.5)	6.00 (152.4)	4.00 (101.6)	0.75 (19.0)	4	0.75 (19.0)	5.00 (127.0)	0.06 (1.5)	8.62 (218.9)	3.50 (88.9)	3/8-16 UNC	0.75 (19.0)	44.3	20.1
		300#	12.5 (317.5)					8.25 (209.6)	6.62 (168.1)	4.50 (114.3)	0.88 (22.4)		1.12 (28.4)		11.25 (285.8)	65.9				29.9	
		600#	14.00 (355.6)					1.32 (33.5)	12.12 (307.8)	77.0	34.6										
Regular Port	4"	150#	11.50 (292.1)	9.00 (228.6)	3.00 (76.2)	3.38 (85.8)	9.00 (228.6)	7.50 (190.5)	4.88 (124.0)	0.75 (19.0)	8	0.94 (23.9)	6.19 (157.2)	0.06 (1.5)	10.5 (266.7)	4.00 (101.6)	7/16-14 UNC	0.88 (22.4)	61.6	27.9	
		300#	14.00 (355.6)				10.00 (254.0)	7.88 (200.2)	5.62 (142.7)	0.88 (22.4)		1.25 (31.8)		12.69 (322.3)	107.8	48.8					
		600#	17.00 (431.8)				10.75 (273.0)	8.50 (215.9)	1.00 (25.4)	1.56 (39.6)		0.25 (6.4)		14.88 (378.0)	4.50 (114.3)	145.0			65.7		
Regular Port	6"	150#	15.50 (393.7)	12.51 (317.8)	21.37 (542.8)	4.00 (101.6)	4.56 (115.8)	11.00 (279.4)	9.50 (241.3)	6.50 (165.1)	0.88 (22.4)	12	1.00 (25.4)	8.50 (215.9)	0.06 (1.5)	14.38 (365.2)	4.00 (101.6)	0.75 (19.0)	198.4	89.3	
		300#	15.88 (403.4)					12.50 (317.5)	10.62 (269.7)	7.12 (180.8)	1.44 (36.6)		235.0		105.8						

GV Series: Actuator Mounting Dimensions

Flange Pads

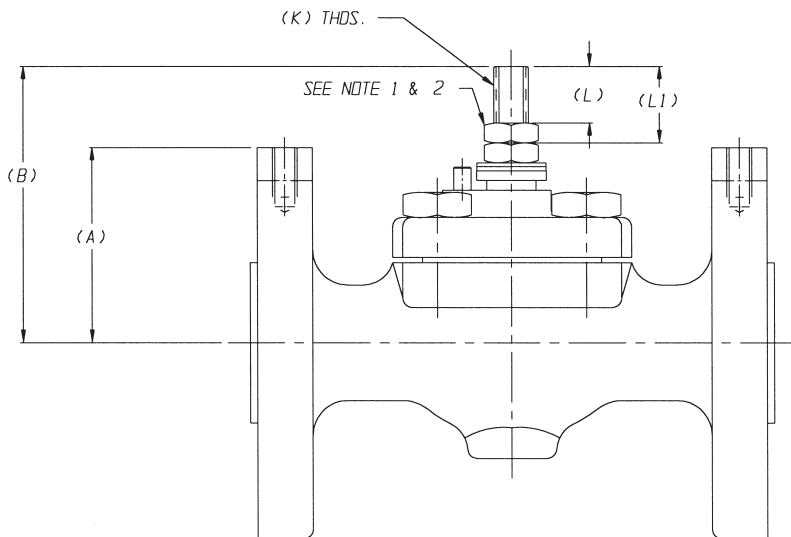
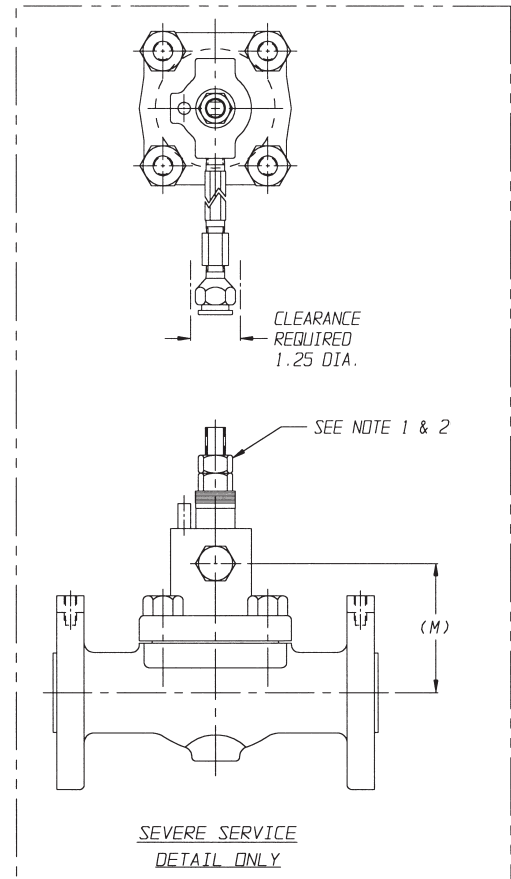
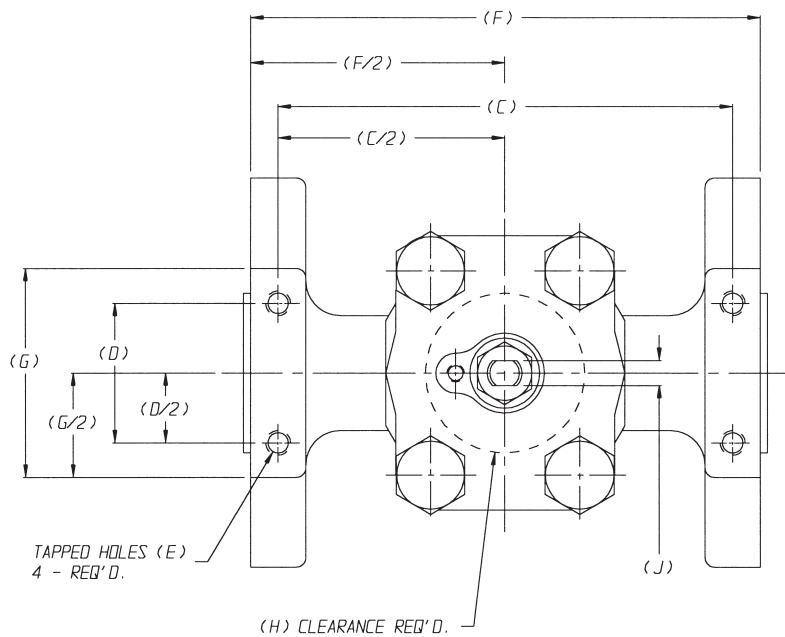

Note

1. Double nuts on actuated valves .5"-2" sizes only.
2. Single nut is used with stem extension kits for all sizes.

VALVE SIZE	PRESS. CLASS	COVER TYPE	(A)	(B)	(C)	(D)	(E)	(F)	(G)	(H)	(J)	(K)	(L)	(L1)	(M)
1/2"	150#	STANDARD	1.94	3.47	3.62	2.00	0.25-20UNC x 0.38 DP.	4.12	2.62	2.00	0.309 0.305	0.438-14UNC	0.58	0.83	-
		EXTENDED		4.97						2.31			1.19	0.94	2.78
		SEVERE SERV.		5.34						2.00			0.58	0.83	-
	300#	STANDARD	2.06	3.47	5.38			2.00		2.31			1.19	0.94	2.78
		EXTENDED		4.97				2.00		0.58			0.83	-	
		SEVERE SERV.		5.34				2.31		1.19			0.94	2.78	
	600#	STANDARD	2.50	3.47	6.31			2.00		2.31			1.19	0.94	2.78
		EXTENDED		4.97				2.00		0.58			0.83	-	
		SEVERE SERV.		5.34				2.31		1.19			0.94	2.78	
3/4"	150#	STANDARD	2.12	3.47	4.00	1.75	0.312-18UNC x .47/.56 DEEP	4.50	3.12	2.00	0.372 0.368	0.50-13UNC	0.58	0.83	-
		EXTENDED		4.97						2.31			1.19	0.94	2.78
		SEVERE SERV.		5.34						2.00			0.58	0.83	-
	300#	STANDARD	2.56	3.47	7.19			2.00		2.31			1.19	0.94	2.78
		EXTENDED		4.97				2.00		0.58			0.83	-	
		SEVERE SERV.		5.34				2.31		1.19			0.94	2.78	
	600#	STANDARD	3.00	3.47	7.25			2.00		2.31			1.19	0.94	2.78
		EXTENDED		4.97				2.00		0.58			0.83	-	
		SEVERE SERV.		5.34				2.31		1.19			0.94	2.78	
1 1/2"	150#	STANDARD	3.00	4.10	5.62	2.25	0.438-14UNC x 0.88 DP.	6.38	4.62	2.00	0.622 0.618	1.00-8UNC	0.60	0.91	-
		EXTENDED		5.85						3.19			0.78	1.09	3.32
		SEVERE SERV.		6.35						2.00			0.60	0.91	-
	300#	STANDARD	3.31	4.10	8.06			2.00		3.19			0.78	1.09	3.32
		EXTENDED		5.85				2.00		0.60			0.91	-	
		SEVERE SERV.		6.35				3.19		0.78			1.09	3.32	
	600#	STANDARD	3.75	4.10	8.00			2.00		3.19			0.78	1.09	3.32
		EXTENDED		5.85				2.50		0.97			1.34	-	
		SEVERE SERV.		6.35				3.38		0.93			1.30	3.81	
2"	150#	STANDARD	3.12	4.87	7.19	4.00	0.438-14UNC x 0.75 DP.	7.88	5.00	2.50	0.747 0.743	1.25-7UNC	0.97	1.34	-
		EXTENDED		6.87						3.38			0.93	1.30	3.81
		SEVERE SERV.		7.19						2.50			0.97	1.34	-
	300#	STANDARD	3.75	4.87	9.50			2.50		3.38			0.93	1.30	3.81
		EXTENDED		6.87				2.50		0.97			1.34	-	
		SEVERE SERV.		7.19				3.38		0.93			1.30	3.81	
	600#	STANDARD	4.00	4.87	9.88			2.50		3.38			0.93	1.30	3.81
		EXTENDED		6.87				3.00		0.90			-		
		SEVERE SERV.		7.19				4.50		1.09			5.03		
3"	150#	STANDARD	4.00	5.89	8.62	3.50	0.375-16UNC x 0.75 DP.	9.38	4.62	3.00	0.622 0.618	1.00-8UNC	0.90	-	
		EXTENDED		8.14						4.50			1.09	5.03	
		SEVERE SERV.		9.22						3.00			0.90	-	
	300#	STANDARD	4.50	5.89	11.25			3.00		4.50			1.09	5.03	
		EXTENDED		8.14				3.00		0.90			-		
		SEVERE SERV.		9.22				4.50		1.09			5.03		
	600#	STANDARD	5.62	5.89	12.12			3.00		4.50			1.09	5.03	
		EXTENDED		8.14				3.50		1.10			-		
		SEVERE SERV.		9.22				5.31		1.08			5.97		
4"	150#	STANDARD	4.88	7.11	10.50	4.00	0.438-14UNC x 0.88 DP.	11.38	5.00	3.50	0.747 0.743	1.25-7UNC	1.10	-	
		EXTENDED		9.48						5.31			1.08	5.97	
		SEVERE SERV.		10.41						3.50			1.10	-	
	300#	STANDARD	5.62	7.05	12.69			3.50		5.31			1.08	5.97	
		EXTENDED		9.43				3.50		1.10			-		
		SEVERE SERV.		10.41				5.31		1.08			5.97		
	600#	STANDARD	7.12	7.05	14.88			3.50		5.31			1.10	-	
		EXTENDED		9.43				1.08		5.97					
		SEVERE SERV.		10.41				1.69		-					
6"	150#	STANDARD	6.50	10.20	14.38	4.00	0.438-14UNC x 0.75 DP.	15.32	5.25	6.00	1.247 1.243	2.00-12UNC	1.30	6.68	
		EXTENDED		13.45									1.69	-	
		SEVERE SERV.		10.20									1.30	6.68	
	300#	STANDARD	7.12	10.20	14.38			15.70					1.69	-	
		EXTENDED		13.45				1.30					6.68		
		SEVERE SERV.		-				-					-		
	-	STANDARD	-	-	-			-					-	-	-
		EXTENDED		-				-					-	-	
		SEVERE SERV.		-				-					-	-	

Dimensions

Extended Bonnet Valves

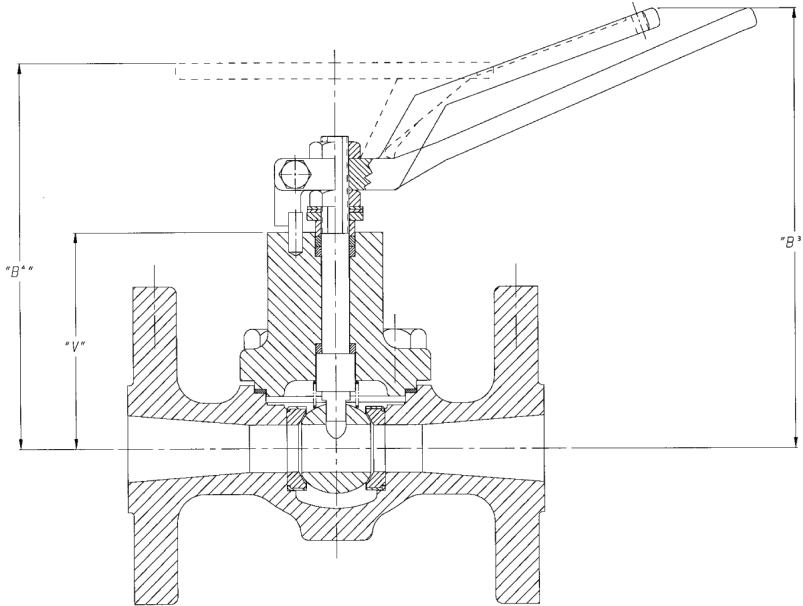

Dimensions in inches
and (mm)

VALVE SIZE	"B³" DIM	"B⁴" DIM	"V" DIM
1/2"			
3/4"	6.65 (168.9)	6.12 (155.4)	3.41 (86.6)
1"			
1-1/2"	7.44 (189.0)	6.91 (175.5)	4.14 (105.2)
2"	8.80 (223.5)	7.54 (191.5)	4.63 (117.6)

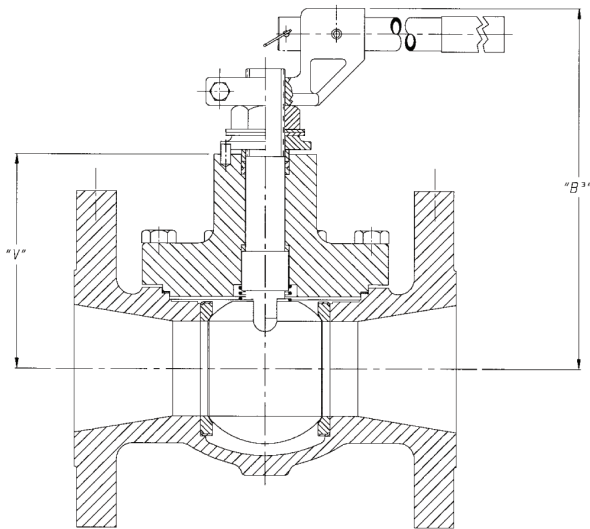

VALVE SIZE	"B³" DIM	"V" DIM
3"	10.30 (261.6)	5.84 (148.3)
4"	11.46 (291.1)	6.79 (172.5)
6"	15.50 (393.7)	8.62 (218.9)

The basic dimensions shown above are for Cam-Tite® Ball Valves with extended bonnets as described on page 11. All components with the exception of the bonnet and stem are interchangeable on valves with standard bonnets.

Parts identification and materials are also consistent with the standard bonnet and are described for the various configurations on pages 22-37. For complete dimensions and materials of construction for the extended bonnet, consult the factory.

Severe Service Bonnet Valves

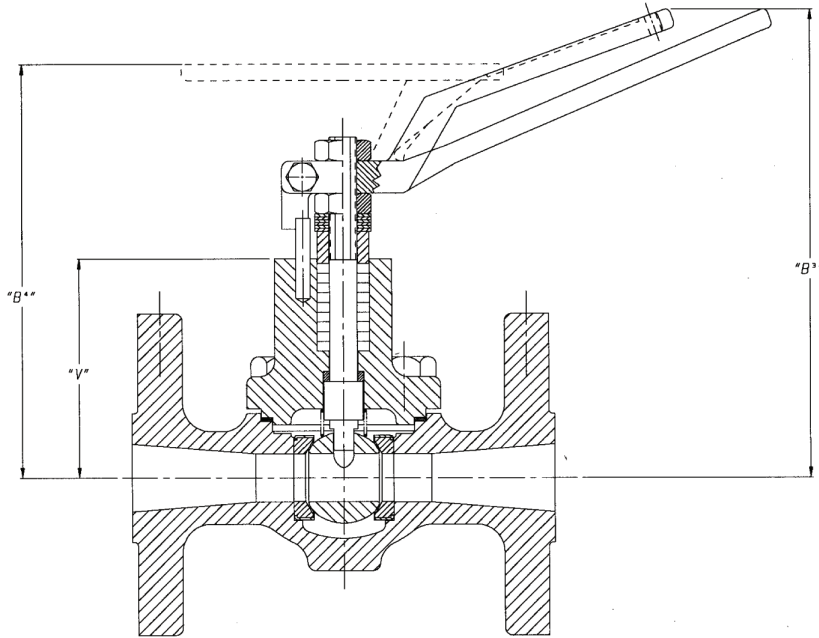

VALVE SIZE	"B3" DIM	"B4" DIM	"V" DIM
1/2"	6.91 (175.5)	6.36 (161.5)	3.41 (86.6)
3/4"			
1"			
1-1/2"	8.03 (204.0)	7.19 (182.6)	4.14 (105.2)
2"	9.05 (229.9)	7.80 (198.1)	4.63 (117.6)

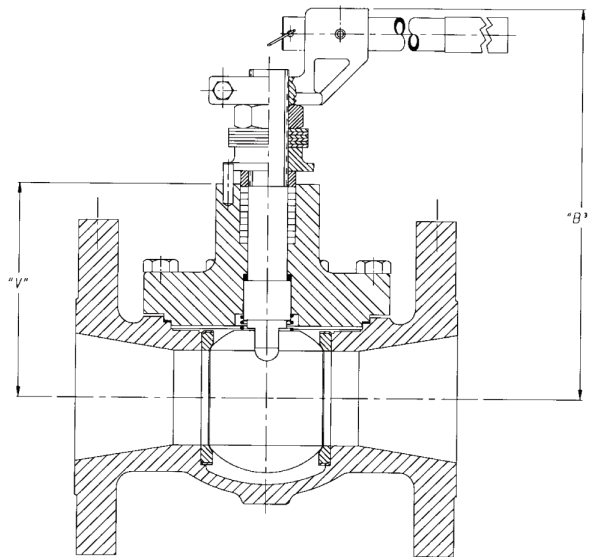

VALVE SIZE	"B3" DIM	"V" DIM
3"	11.13 (282.7)	5.84 (148.3)
4"	12.33 (313.2)	6.79 (172.5)
6"	15.77 (400.6)	8.62 (218.9)

The basic dimensions shown above are for Cam-Tite Ball Valves with severe service bonnets as described on page 11. All components with the exception of the bonnet, stem, and stem seals are interchangeable on valves with standard bonnets. Otherwise, parts identification and

materials are consistent with the standard bonnet and are described for the various configurations on pages 22-37. For complete dimensions and materials of construction for the severe service bonnet, consult the factory.

Service Guide

The following charts have been assembled based on experiences in actual field installations, as well as from commonly published corrosion data. Due to the many variables involved in determining the degree of compatibility between a certain material and a certain fluid, the charts must be used as a guide only, and cannot be interpreted as a guarantee. Factors such as temperature, concentration, pressure, velocity, aeration, abrasion, cavitation, flashing, etc play an important application role in determining the suitability of any material in a particular application and must also be taken into consideration.

The selection of a suitable valve body material for a particular application is much easier than the selection of other valve components such as seats, ball, stem and packing.

A certain amount of corrosion is sometimes acceptable on the valve body, but the seats, ball and stem materials must be chosen carefully since corrosion of these components will likely affect the sealing characteristics of the valve.

In addition to the compatibility of the material to the fluid, care must be taken to select materials and designs that are capable of withstanding the actual pressures and temperatures. Consult pages 16–17 of this catalog for pressure / temperature ratings of valves with various seats.

Engineered Valves cannot accept responsibility for the accuracy, currency or reliability of the information contained herein. Selection of materials is at the sole risk of the user. Consult factory for services not listed.

Chemicals	Body/Trim					Seats/Packing					
	Carbon Steel	316 Stainless Steel	Alloy 20	Monel	Hastelloy C	EPDM	PEEK	Graphite	PTFE	Reinforced (PTFE)	UHMWPP
Acetaldehyde	C	A	A	A	A	B	A	A	A	A	D
Acetamide	B	B			A			A	A	A	
Acetate Solvents	A	A		A	A		A	A	A	A	
Acetic Acid, Aerated	D	A		A	A			A	A	A	
Acetic Acid, Air Free	D	A	A	A	A			A	A	A	
Acetic Acid, Crude	C	A	A	B	A			A	A	A	
Acetic Acid, Glacial		D			A	B	A	A	A	A	
Acetic Acid, Pure	D	A	A	C	A		A	A	A	A	C
Acetic Acid, 10%	C	A	A	B	A	B		A	A	A	A
Acetic Acid, 80%	C	A	A	B	A	C		A	A	A	C
Acetic Acid Vapors		D	B	C	A		A	A	A	A	
Acetic Anhydride	D	B	B	B	A	C	A	A	A	A	C
Acetone	A	A	A	A	A	A	A	A	A	A	A
Acetyl Chloride		C		B	A	D	A	A	A	A	
Acetylene	A	A	A	A	A	A	A	A	A	A	
Acrylonite	A	A	B	A	A	D		A	A	A	
Acrylonitrile	A	A	A	A				A	A		
Adipic Acid	A	A	B	B			B		A	A	
Acid Fumes	D	B	B					C	A	A	
Air	A		A	A	A	A	A	B	A	A	A
Albumen		A							A		

A = Excellent

B = Fair

Chemicals	Body/Trim					Seats/Packing					
	Carbon Steel	316 Stainless Steel	Alloy 20	Monel	Hastelloy C	EPDM	PEEK	Graphite	PTFE	Reinforced (PTFE)	UHMWPP
Alcohol, Allyl	A	A	A	A					A	A	
Alcohol, Amyl	B	A	B	B	B	A	A	A	A	A	
Alcohol, Benzyl		A			A				A	A	
Alcohol, Butyl	B	A	A	A	A	C	A	A	A	A	
Alcohol, Diacetone	A	A	A	B	A	B		A	A	A	
Alcohol, Ethyl	B	B	A	B	A	A	A	A	A	A	A
Alcohols, Fatty	B	A	A		A			A	A	A	
Alcohol, Furfuryl		A							A	A	
Alcohol, Isopropyl	B	B	A	B	B	A		A	A	A	
Alcohol, Methyl	B	A	A	A	A	A	A	A	A	A	
Alcohol, Propyl	B	A	A	A	A	A	A	A	A	A	
Alumina		A			A	A	A	A	A	A	
Aluminum Acetate		A	B	C	B	A	A	A	A	A	A
Aluminum Chloride Dry	C	C	D	B	B	A	A	A	A	A	
Aluminum Chloride Solution		D	B	B	A		A	A	A	A	A
Aluminum Fluoride	D	C		B	A	A		A	A	D	A
Aluminum Hydroxide	D	A	B	B	B	A		A	A	A	A
Aluminum Nitrate		C	B	C	B	B		B	A	A	
Alum (Aluminum Potassium Sulfate)		B	B	C	A			A	A	A	A
Aluminum Sulfate	D	B	B	C	A	A		A	A	A	A

C = Poor

D = Not Recommended

Chemicals	Body/Trim				Seats/Packing						
	Carbon Steel	316 Stainless Steel	Alloy 20	Monel	Hastelloy C	EPDM	PEEK	Graphite	PTFE	Reinforced (PTFE)	UHMWP
Amines	B	A	A	B	B	C	A	A	A	A	
Ammonia, Alum		A	A		A			A	A	A	
Ammonia, Anhydrous Liquid	A	A	A	B	A	B	A	A	A	A	
Ammonia, Aqueous	A	A	A	B	B		A	A	A	A	
Ammonia Gas, Hot		A	A	B	B	A	A	A	A	A	A
Ammonia Liquor		A	A		B			A	A	A	
Ammonia Solutions	B	A	A	B	B	B		A	A	A	
Ammonium Acetate		B	A	B	B	A		A	A	A	
Ammonium Bicarbonate	C	B	B	B		A		A	A	A	A
Ammonium Bromide 50%		B	B	B				A	A	A	A
Ammonium Carbonate	B	B	B	B		A		A	A	A	A
Ammonium Chloride	D	C	B	B	B	A	A	A	A	A	A
Ammonium Hydroxide 28%	C	B	A	D	B	B		A	A	A	A
Ammonium Hydroxide, Concentrated	C	B	A	C	B	A		A	A	A	A
Ammonium Monophosphate	D	B	B	B				A	A		
Ammonium Monosulfate		A	B	B	B			A	A	A	
Ammonium Nitrate	D	A	B	D	B	A		B	A	A	A
Ammonium Persulfate		A	A	D		B		A	A	A	
Ammonium Phosphate	D	B	B	C		A		A	A	A	A
Ammonium Phosphate Di-basic	D	B	B	C	B			A	A	A	
Ammonium Phosphate Tri-basic	D	B	B	C	B		A	A	A		
Ammonium Sulfate	C	B	B	B	B	A		A	A	A	A
Ammonium Sulfide	D	B	B	B		A		A	A	A	A
Ammonium Sulfite	C	A	B	D		B		A	A	A	
Amyl Acetate	C	B	A	B	A	B		A	A	A	A
Amyl Chloride		A	A	B	B	D		A	A	A	D
Aniline	C	B	A	B	B	C		A	A	A	A
Aniline Dyes	C	A	A	A		C		A	A	A	
Antimony Trichloride	D	D	C	B				A	A		
Aqua Regia (Strong Acid)	D	B	B			D	D	D	A	A	C
Aromatic Solvents	C	A	A	B		D		A	A	A	
Arsenic Acid	D	B	B	D	B	B		A	A	A	A
Barium Carbonate	B	B	B	B	A	A		A	A	A	A
Barium Chloride	C	B	C	B		A		A	A	A	A
Barium Cyanide		B	B	D		B		A	A	A	
Barium Hydrate		A	A	B				A	A	A	
Barium Hydroxide	C	B	A	B		B		A	A	A	A
Barium Nitrate		A		A				B	A	A	

Chemicals	Body/Trim				Seats/Packing						
	Carbon Steel	316 Stainless Steel	Alloy 20	Monel	Hastelloy C	EPDM	PEEK	Graphite	PTFE	Reinforced (PTFE)	UHMWP
Barium Sulfate	C	A	A	B		B		A	A	A	A
Barium Sulfide	C	B	B	C		A		A	A	A	A
Benzaldehyde	A	A	A	B	B	A		A	A	A	D
Benzene (Benzol)	B	B	A	A	B	D	D	A	A	A	D
Benzoid Acid	D	B	B	B	A	D		A	A	A	A
Beryllium Sulfate		B	A	B		B		A	A	A	
Benzyl Chloride	B	B							A	A	
Black Sulfate Liquor	C	B	B	B					A	A	
Bleaching Powders	D	B	B	D					A	A	
Bleaching Powder, Wet		C	B	D	A	B		A	A	A	A
Blood (Meat Juices)		A	A	B		B	A	A	A	A	
Borax (Sodium Borate)	C	A		A	A	A	A	A	A	A	A
Bordeaux Mixture		A	A					A	A	A	
Boric Acid	D	B	B	B	A	B	A	A	A	A	A
Brake Fluid		B		B		B		A	A	A	
Brines, saturated	D	B	B	B	A	A		A	A	A	A
Bromine, Dry	D	D	B	A	A	D	D	B	A	A	D
Bromine, Wet	D	D	D	D					A	A	
Bromic Acid									A	A	
Bunker Oils (Fuel)	B	A	A	A				A	A	A	D
Butadiene	B	A	A	C	B	C	A	A	C	C	D
Butane	B	A	A	B	A	D	A	A	A	A	A
Butyl Acetate		B	A	B	B	D		A	A	A	D
Butylene	A	A	A	A		D	A	A	A	A	
Butyric Acid	D	B	B	B	A	C	A	A	A	A	D
Calcium Bisulfite	D	B	B	D	B	D		A	A	A	
Calcium Carbonate	D	B	B	B	B	B	A	A	A	A	A
Calcium Chlorate		B	B	B		B		B	A	A	A
Calcium Chloride	C	B	B	B	A	B	A	A	A	A	A
Calcium Hydroxide	C	B	B	A	A	A	A	A	A	A	A
Calcium Hypochlorite	D	C	B	C					A	A	
Calcium Nitrate		B	B			B		B	A	A	A
Calcium Phosphate		B	B			B		A	A	A	A
Calcium Silicate		B	B			B		A	A	A	
Calcium Sulfate	C	B	B	B	B	B	A	A	A	A	A
Camphor		B	C	C		B		A	A	A	D
Cane Sugar Liquors		A	A	B		B		A	A	A	
Carbolic Acid (Phenol)	D	B	A	B		B	A	A	A	A	
Carbonated Beverages	D	B	B	C		B		A	A	A	
Carbonated Water	B	A	A	B		A		A	A	A	A
Carbon Bisulfide	B	B	B	B		D		A	A	A	D

A = Excellent

B = Fair

C = Poor

D = Not Recommended

Chemicals	Body/Trim				Seats/Packing						
	Carbon Steel	316 Stainless Steel	Alloy 20	Monel	Hastelloy C	EPDM	PEEK	Graphite	PTFE	Reinforced (PTFE)	UHMWP
Carbon Dioxide, Dry	A	A	A	A		B		A	A	A	A
Carbon Monoxide		A	A	A	A	B	A		A	A	A
Carbon Tetrachloride, Dry	B	A	A	A	A	D	A	A	A	A	D
Carbon Tetrachloride, Wet	D	B	B	B	B	D	A	A	A	A	D
Castor Oil	B	A	A	A	A	B		A	A	A	A
Caustic Potash (KOH)		A	A	B			B	A	A	A	
Caustic Soda (NaOH)	B	A	A	A		B	B	A	A	A	
Cellulose Acetate		B		B	B	B		A	A	A	
Chlorinated Solvents	C	A	A	B		D	D	A	A	A	
Chlorinated Water		C	A	D	D		D	A	A	A	C
Chlorine, Dry	B	D	B	A	A				A	A	
Chlorine, Wet	D	D	C	D	A				A	A	
Chlorine Gas, Dry	B	B	A	A	A	D	D	A	A	A	D
Chlorobenzene, Dry	B	A	A	B	B	D	B	A	A	A	D
Chloroform, Dry	B	A	A	A	B	D		A	A	A	
Chlorophyll, Dry		B	A	B		B		A	A	A	
Chlorosulfonic Acid, Dry	B	B	B	B	A	D	D		A	D	D
Chlorosulfonic Acid, Wet	D	D	D	C					A	A	
Chrome Alum	B	A	A	B		B		A	A	A	A
Chromic Acid <50%	D	C	B	C	B	C	D	A	A	A	A
Chromic Acid >50%	D	C	B	D	B	C	D	A	A	A	
Chromium Sulfate		B	C	B		B		A	A	A	
Citric Acid	D	B	A	B	A	B	A	A	A	A	A
Coke Oven Gas	B	A	A	B		D		A	A	A	
Cooking Oil	B	A	A	A		D		A	A	A	
Copper Acetate	D	A	A	C	B	B		A	A	A	
Copper Carbonate		A	A					A	A	A	
Copper Chloride	D	D	D	C					A	A	
Copper Cyanide		A	A	C		B		A	A	A	A
Copper Nitrate	D	B	B	D		B		B	A	A	A
Copper Sulfate	D	B	B	C	A	A		A	A	A	A
Corn Oil	C	B	B	B		C		A	A	A	A
Cottonseed Oil	C	B	B	B		C	A	A	A	A	A
Cresol		B	B			D		A	A	A	D
Creosote Oil	B	B	A	B	B	D	A	A	A	A	D
Cresylic Acid	C	B	B	B		D		A	A	A	A
Crude Oil, Sour	B	A	A	B		D		A	A	A	
Crude Oil, Sweet	B	A	A	A			A	A	A	A	
Cumeme	B	B	B	B					A	A	
Cupric Nitrate		A	A	D				B	A	A	
Cutting Oils (Water Emulsions)	B	A		A				A	A	A	

Chemicals	Body/Trim				Seats/Packing						
	Carbon Steel	316 Stainless Steel	Alloy 20	Monel	Hastelloy C	EPDM	PEEK	Graphite	PTFE	Reinforced (PTFE)	UHMWP
Cyanide Plating Solution		B	B	D		B		A	A	A	
Cyclohexane	A	A	A	B	B	D	A	A	A	A	C
Cyclohexanone		A	A	B	B		B	A	A	A	D
Denatured Alcohol	B	A	A	A					A	A	
Detergents, Synthetic		B	A	B		B		A	A	A	A
Dextrin		B	B	B		B		A	A	A	A
Diacetone Alcohol	A	A	A	A					A	A	
Diamylamine		A	A						A	A	
Dibutyl Phthalate									A	A	
Dichloroethane		C	B	B		D		A	A	A	
Dichloroethyl Ether		B	B			D			A	A	
Diesel Oil Fuels	A	A	A	A		D		A	A		
Diethylamine	A	A	A	B		C		A	A	A	
Diethyl Benzene		B	B			D		A	A	A	
Diethylene Glycol		A	A	B		A	A	A	A	A	A
Diethyl Sulfate		B	B	B		C		A	A	A	
Dimethyl Formamide		A	A	B		D	A	A	A	A	
Dimethyl Phthalate		D						A	A	A	
Dioxane		B	B	B		C	A	A	A	A	
Dipentane (Pinene)		A	A			D		A	A	A	
Disodium Phosphate		B	B	C				A	A	A	A
Dowtherm	B	A	A	A		D	A	A	A	A	
Drilling Mud	B	A	A	B		A		A	A	A	
Dry Cleaning Fluids	B	A	A	B				A	A	A	
Drying Oil	C	B	B	B				A	A	A	
Enamel		A				D		A	A	A	
Epsom Salts (MgSo4)	C	B	B	B				A	A	A	
Ethane	C	B	B	B		D	A	A	A	A	
Ether	A	A	A	B		C	A	A	A	A	D
Ethyl Acetate	B	B	B	B	B	C		A	A	A	C
Ethyl Acrylate	C	A	A	B	A	C		A	A	A	
Ethylamine		A							A	A	A
Ethyl Benzene		B	A		A	D		A	A	A	
Ethyl Bromide		B	C	B		B		A	A	A	
Ethyl Chloride, Dry	B	A	A	B	B	C		A	A	A	D
Ethyl Chloride, Wet	D	B	B	B	B	B		A	A	A	A
Ethylene	A	A	A	A					A	A	
Etylenediamene		A							A	A	
Ethylene Chloride			A	A	B	B		A	A	A	
Ethylene Dichloride, Dry	B	A	A	A					A	A	
Ethylene Dichloride, Wet	D	C	A	B					A	A	

A = Excellent

B = Fair

C = Poor

D = Not Recommended

Chemicals	Body/Trim					Seats/Packing					
	Carbon Steel	316 Stainless Steel	Alloy 20	Monel	Hastelloy C	EPDM	PEEK	Graphite	PTFE	Reinforced (PTFE)	UHMW
Ethylene Glycol	B	B	A	B	A	A	A	A	A	A	A
Ethylene Oxide	B	B	B	B	A	D	A	D	A	A	C
Ethyl Ether		A	A	A	B	D	A	A	A	A	
Ethyl Silicate		B	B	B		B		A	A	A	
Ethyl Sulfate		B	B			C		A	A	A	
Fatty Acids	D	A	A	B	A	D	A	A	A	A	A
Ferric Chloride	D	D	D	D					A	A	
Ferric Hydroxide		A	A	A				A	A	A	
Ferric Nitrate	D	C	A	D	B	A		B	A	A	A
Ferric Sulfate	D	B	A	D		A		A	A	A	A
Ferrous Ammonium Citrate		B	B					A	A	A	A
Ferrous Chloride	D	D	D	D	D	A		A	A	A	A
Ferrous Sulfate	D	B	B	B	B	A		A	A	A	A
Ferrous Sulfate, Saturated	C	A	A	B	B	B		A	A	A	
Fertilizer Solutions	B	B	B	B				A	A	A	
Fish Oils	B	A	A	A		D		A	A	A	
Flue Gases		A	A	B		D		A	A	A	
Fluoride Salts		B							A	D	
Fluorine Gas, Dry		B	A	A	A		D		A	D	
Fluoboric Acid		B	A						A	D	A
Fluorosilicic Acid	D	B	B	A	B	C			A	D	A
Formaldehyde, Cold	A	A	A	A	B	B		A	A	A	A
Formaldehyde, Hot	D	C	B	B	B			A	A	A	A
Formic Acid, Cold	D	B	A	B	A			A	A	A	A
Formic Acid, Hot	D	B	B	B	B			A	A	A	A
Freon Gas, Dry	B	A	A	A	B	C	A	A	A	A	
Freon 11, MF, 112, BF		A	A	B	B	C	A	A	A	A	
Freon 12, 13, 32, 114, 115		A	A	B	B	A	A	A	A	A	
Freon 21, 31		A	A	B	B	D	A	A	A	A	
Freon 22		A	A		B	D	A	A	A	A	
Freon 113, TF		A	A	B	B	C	A	A	A	A	
Freon, Wet		C	B	B	B	B	D	A	A	A	
Fuel Oil	B	A	A	B			D	A	A	A	D
Fumaric Acid			A						A	A	
Gallic Acid 5%	D	B	B	B	B	C			A	A	A
Gas, Manufactured	B	B	B	A		D		A	A	A	
Gas, Natural	B	A	B	A		D		A	A	A	
Gas, Odorizers	B	B	A	B				A	A	A	
Gasoline, Aviation	A	A	A	A	A			A	A	A	D
Gasoline, Leaded	A	A	A	B	A		A	A	A	A	D
Gasoline, Motor	A	A	A	A	A	D		A	A	A	D

A = Excellent

B = Fair

C = Poor

D = Not Recommended

Chemicals	Body/Trim					Seats/Packing					
	Carbon Steel	316 Stainless Steel	Alloy 20	Monel	Hastelloy C	EPDM	PEEK	Graphite	PTFE	Reinforced (PTFE)	UHMW
Gasoline, Refined	B	A	A	B	A	D		A	A	A	D
Gasoline, Sour	B	A	A	C	A	D		A	A	A	D
Gasoline, Unleaded	A	A	A	A	A			A	A	A	D
Glue	A	B	A	B	A	B	A	A	A	A	A
Glutamic Acid		B	A						A	A	
Glycerine (Glycerol)	C	A	A	A	A	A	A	A	A	A	A
Glycol Amine		B				D	D		A	A	A
Glycol	C	B	A	B			A	A	A	A	A
Helium Gas		A	A	B	A	B	A	A	A	A	A
Heptane	B	A	A	B	A	D	A	A	A	A	C
Hexane	B	A	A	B	A	D	A	A	A	A	D
Hexanol, Tertiary	A	A	A	A	A	D		A	A	A	A
Hydraulic Oil, Petroleum Base	A	A	A	A			D		A	A	A
Hydrazine		B	B	D		B			A	A	
Hydrobromic Acid	D	D	D	D					A	A	
Hydrochloric Acid	D	D	D	D					A	A	
Hydrocyanic Acid	D	A	A	C	B	B	A		A	A	A
Hydrofluoric Acid, Anhydrous	B	B	B	A					A	D	
Hydrofluosilicic Acid	D	C	B	B		B	D	A	A	D	
Hydrogen Gas, Cold	B	A	A	A		B	A	A	A	A	A
Hydrogen Gas, Hot	B	B	A			A	B	A	A	A	A
Hydrogen Bromide Gas									A	A	
Hydrogen Chloride Gas, Dry	D	B	A	B					A	A	
Hydrogen Peroxide, Concentrated	D	B	B	D	D	D	B	A	D	A	C
Hydrogen Peroxide, Dilute	D	B	B	D	D	D	B	A	C	A	A
Hydrogen Sulfide, Dry	B	A	B	B	B		A	A	A	A	A
Hydrogen Sulfide, Wet	C	B	B	C	D		B	A	A	A	A
Hypo (Sodium Thiosulfate)	D	B	B	B			A		A	A	A
Illuminating Gas	A	A	A	A			D		A	A	A
Ink-Newsprint	D	A	A	B			B		A	A	A
Iso-Butane		B	B				D		A	A	A
Iso-Octane	A	A	A	A			D	A	A	A	A
Isopropyl Acetate		B	A				D	A	A	A	A
Isopropyl Ether	A	A	A	B	A		D	A	A	A	A
J P-4 Fuel	A	A	A	A	A			A	A	A	A
J P-5 Fuel	A	A	A	A	A			A	A	A	A
J P-6 Fuel	A	A	A	A	A			A	A	A	A
Kerosene	B	A	A	A	A		D	A	A	A	C
Ketones	A	A	A	A			D	A	A	A	A
Lacquer (and Solvent)	C	A	A	A			D	A	A	A	A

Chemicals	Body/Trim				Seats/Packing						
	Carbon Steel	316 Stainless Steel	Alloy 20	Monel	Hastelloy C	EPDM	PEEK	Graphite	PTFE	Reinforced (PTFE)	UHMWPP
Lactic Acid Concentrated, Cold	D	A	A	D	A	B	A	A	A	A	A
Lactic Acid Concentrated, Hot	D	B	A	D	B	B	A	A	A	A	A
Lactic Acid Dilute Cold	D	A	A	C	A	B	A	A	A	A	A
Lactic Acid Dilute Hot	D	A	A	D	B		A	A	A	A	A
Lactose		B	B	B		B		A	A	A	
Lard Oil	C	B	A	B		B	A	A	A	A	A
Lead Acetate	D	B	B	B		B	A	A	A	A	A
Lead Arsenate	B								A	A	
Lead Oxide									A	A	
Lead Sulfate		B	B	B		B		A	A	A	
Lecithin		B	B	B		D			A	A	
Linoleic Acid	B	A	A	B		D		A	A	A	
Linseed Oil	A	A	A	B		D	A	A	A	A	A
Lithium Chloride		B	A	B		B	A	A	A	A	
LPG	B	B	B	B		D	A	A	A	A	
Lubricating Oil (Petroleum Based)	A	A	A	B		D		A	A	A	C
Lye — See Sodium Hydroxide & Potassium Hydroxide											
Magnesium Bisulfate	B	A	A	B		B	A	A	A	A	
Magnesium Bisulfide		B	B	B		B	A	A	A	A	
Magnesium Carbonate		A	A	B		B	A	A	A	A	A
Magnesium Chloride	C	B	B	B	A	A	A	A	A	A	A
Magnesium Hydroxide	B	A	A	B	B	A	A	A	A	A	A
Magnesium Hydroxide, Hot	B	A	A	A	B		A	A	A	A	A
Magnesium Oxide									A	A	
Magnesium Nitrate		A	A	B			A	B	A	A	A
Magnesium Sulfate	B	A	A	B	A	A	A	A	A	A	A
Maleic Acid	B	B	B	B	A	D	A	A	A	A	A
Maleic Anhydride		B	B	B	B	D		A	A	A	
Malic Acid	D	B	B	B			A	A	A	A	
Manganese Carbonate		B	A				A	A	A	A	
Manganese Sulfate		A	A	B		B	A	A	A	A	
Meat Juices		A	A					A	A	A	A
Melamine Resins		C	C					A	A	A	
Methanol		A	A	B		D		A	A	A	
Mercuric Chloride	D	B	B	D	B	A	A	A	A	A	A
Mercuric Cyanide	D	A	A	C	B	A	A	A	A	A	A
Mercurous Nitrate		A	A	D			A	B	A	A	A
Mercury	A	A	A	B	B	A	A	A	A	A	A
Methane	B	A	A	B	A		A	A	A	A	
Methyl Acetate	B	A	A	B	A	B	A	A	A	A	

Chemicals	Body/Trim				Seats/Packing						
	Carbon Steel	316 Stainless Steel	Alloy 20	Monel	Hastelloy C	EPDM	PEEK	Graphite	PTFE	Reinforced (PTFE)	UHMWPP
Methyl Acetone	A	A	A	A		A	A	A	A	A	
Methylamine	B	A	A	C	B	B	A	A	A	A	
Methyl Bromide 100%		B	A	B		D	A	A	A	A	D
Methyl Cellosolve	B	A	A	B	B	B		A	A	A	
Methyl Cellulose		A	A		B			A	A	A	
Methyl Chloride	B	A	A	B		D	A	A	A	A	D
Methyl Ethyl Ketone	A	A	A	A	B	B	C	A	A	A	D
Methylene Chloride	B	A	A	B	B	D	A	A	A	A	D
Methyl Formate	C	B	A	B	B	B		A	A	A	
Methyl Isobutyle Ketone		A	A					A	A	A	
Mineral Oils	B	A	A	A		D	A	A	A	A	D
Mine Water (Acid)	D	C	C	C				A	A	A	
Mineral Spirits	B	B	B	B				A	A	A	D
Molybdc Acid		A	A					A	A	A	
Monochloroacetic Acid	D	D	C	D				A	A	A	
Monocloro Benzene, Dry		B	B	B			B	A	A	A	
Morpholine		A	A	B		B		A	A	A	
Muriatic Acid	D	D	D	D	D			A	A	A	
Naptha	B	B	B	B	A	D	A	A	A	A	D
Napthalene	B	B	B	B	B	D	A	A	A	A	D
Natural Gas, Sour	B	A	A	D	A	D	A	A	A	A	A
Nickel Ammonium Sulfate	D	A	A	C		B		A	A	A	
Nickel Chloride	D	B	A	B	A	B	A	A	A	A	A
Nickel Nitrate	D	B	A	B		A	A	B	A	A	A
Nickel Sulfate	D	B	A	B	B	B	A	A	A	A	A
Nicotinic Acid (Niacin)	B	A	A	A		D		A	A	A	A
Nitric Acid 10%	D	A	A	D			B	B	A	A	A
Nitric Acid 30%	D	A	A	D			B	B	D	A	A
Nitric Acid 80%	D	C	B	D		D	D	D	A	A	D
Nitric Acid 100%	D	A	A	D		D	D	D	A	A	D
Nitric Acid Anhydrous	D	A	A	D		D	D	D	A	A	
Nitrobenzene	B	A	A	B	B	C	C	A	A	A	D
Nitrocellulose	B	B	B	B				A	A	A	
Nitrogen	A	A	A	A		B		A	A	A	A
Nitrous Acid 10%	D	B	B	D			D	A	A	A	
Nitrous Gases	B	A	A	D				A	A	A	A
Nitrous Oxide	B	B	B	D	B			A	A	A	A
Oil, Linseed	A	A	A	B					A	A	
Oil, Lubricating	A	A	A	B					A	A	
Oils Petroleum Refined	A	A	A	A	A	D		A	A	A	A
Oils, Petroleum Sour	B	A	A	A	A	D		A	A	A	A

A = Excellent

B = Fair

C = Poor

D = Not Recommended

Chemicals	Body/Trim					Seats/Packing					
	Carbon Steel	316 Stainless Steel	Alloy 20	Monel	Hastelloy C	EPDM	PEEK	Graphite	PTFE	Reinforced (PTFE)	UHMWPP
Oils Water Mixture	B	A	A	A	A	A	A	A	A	A	
Olaic Acid		B	B	A				A	A	A	
Oleic Acid	C	B	A	B	B	D	D	A	A	A	C
Oleum	B	B	B	C	B	D		A	A	D	
Oleum Spirits		B	B	D		D		A	A		
Olive Oil	B	A	A	A		B	A	A	A	A	A
Oxalic Acid	D	B	B	B		B	A	A	A	A	A
Oxygen	B	A	A	A	A	A	D	D	A	A	A
Ozone, Dry	A	A	A	A	A	A	D		A	A	C
Ozone, Wet	C	A	A	A	A	B	D		A	A	C
Paints & Solvents	A	A	A	A		D		A	A	A	A
Palmitic Acid	C	B	B	B		B	A	A	A	A	
Palm Oil	C	B	A	A		D		A	A	A	A
Paraffin	B	A	A	A	A	D	A	A	A	A	C
Paraformaldehyde	B	B	B	B		D		A	A	A	
Paraldehyde		B	B			D		A	A	A	
Pentane	B	A	A	B		D	A	A	A	A	
Perchlorethylene, Dry	B	A	A	B	B	D		A	A	A	
Phenol	D	A	A	A	A	D		A	A	A	D
Phosphate Ester	A	A	A	A		A		A	A	A	
Phosphoric Acid 10% Cold	D	C	B	C					A	A	
Phosphoric Acid 10% Hot	D	C	B	B					A	A	
Phosphoric Acid 50% Cold	D	B	B	C		B	D	A	A	A	A
Phosphoric Acid 50% Hot	D	D	B	C		B	D	A	A	A	A
Phosphoric Acid 85% Cold	B	A	B	A			D	A	A	A	A
Phosphoric Acid 85% Hot	C	B	B				D	A	A	A	A
Phosphoric Anhydride		A	A				D	A	A	A	
Phosphorous Trichloride	B	A	A			B	D	A	A	A	A
Phthalic Acid	C	B	B	A	B		B	A	A	A	
Phthalic Anhydride	C	B	B	A	A			A	A	A	A
Pine Oil	B	A	A	B		D		A	A	A	D
Pitch (Bitumen)		A	A			D		A	A	A	
Polysulfide Liquor		B	A	B		B		A	A	A	
Polyvinyl Acetate		B	B	B		B		A	A	A	
Polyvinyl Chloride		B	B	B	B	B		A	A	A	
Potassium Bicarbonate		A	A	B				A	A	A	A
Potassium Bichromate		A	A	A				A	A	A	
Potassium Bisulfate		A	A	B				A	A	A	
Potassium Bisulfite	D	B	B	D	B			A	A	A	
Potassium Bromide	D	A	B	B	B			A	A	A	A
Potassium Carbonate	B	B	B	B		B		A	A	A	A

Chemicals	Body/Trim					Seats/Packing					
	Carbon Steel	316 Stainless Steel	Alloy 20	Monel	Hastelloy C	EPDM	PEEK	Graphite	PTFE	Reinforced (PTFE)	UHMWPP
Potassium Chlorate	B	B	B	C		B		C	A	A	A
Potassium Chloride	C	B	A	B	B	A		A	A	A	A
Potassium Chromate		B	B	B		B			A	A	A
Potassium Cyanide	B	B	B	B	B	A		A	A	A	A
Potassium Dichromate	C	B	A	B		B			A	A	A
Potassium Ferricyanide	C	A	B	B		B		A	A	A	A
Potassium Ferrocyanide	C	B	B	A				A	A	A	A
Potassium Hydroxide, Dilute Cold	A	B	B	A				A	A	A	A
Potassium Hydroxide, To 70%, Cold	B	B	B	A		B		A	A	A	A
Potassium Hydroxide, Dilute Hot	B	B	B	A				A	A	A	A
Potassium Hydroxide, To 70%, Hot	A	B	B	A		A		A	A	A	A
Potassium Iodide	C	B	B	B	B	B		A	A	A	
Potassium Nitrate	B	B	B	B	B	B		B	A	A	A
Potassium Oxalate		A	A					A	A	A	A
Potassium Permanganate	B	B	B	B	B	B	D		A	A	A
Potassium Phosphate		B	B	B	B	A	D		A	A	A
Potassium Phosphate, Di-basic	A	A	A	B	B	B		A	A	A	
Potassium Phosphate, Tri-basic	A	B	B	B		B		A	A	A	
Potassium Sulfate	B	A	A	B		A		A	A	A	A
Potassium Sulfide	B	A	A	C	A	B		A	A	A	A
Potassium Sulfite	B	A	A	C	B	A		A	A	A	A
Propane Gas B	B	A	B	A	D	A	A	A	A	A	
Propionic Acid	D	B	B	B					A	A	
Propyl Alcohol	B	A	A	A					A	A	
Propyl Bromide		B	A	B		B		A	A	A	
Propylene Glycol	B	B	B	B		B	A	A	A	A	A
Pyridine		B	A					A	A	A	
Pyrolgalic Acid	B	B	A	B					A	A	
Pyroligenous Acid		A	B						A	A	
Quinine, Sulfate, Dry		A	A	B					A	A	A
R P-1 Fuel	A	A	A	A					A	A	A
Rubber Latex Emulsions	B	A	A						A	A	A
Salicylic Acid	D	A	B	B		B	A	A	A	A	A
Salt (NaCl)	C	B	A	A				A	A	A	A
Salt Brine		B	B	B		B	A	A	A	A	A
Sea Water	D	B	B	A		A	A	A	A	A	A
Sewage	C	B	B	B		B	A	A	A	A	A

A = Excellent

B = Fair

C = Poor

D = Not Recommended

Chemicals	Body/Trim				Seats/Packing						
	Carbon Steel	316 Stainless Steel	Alloy 20	Monel	Hastelloy C	EPDM	PEEK	Graphite	PTFE	Reinforced (PTFE)	UHMWPP
Shellac	A	A	A	A		A	A	A	A		
Silicone Fluids		B	B			A	A	A	A	C	
Silver Bromide		A	A	B			A	A	A		
Silver Cyanide		A	A	B			A	A	A		
Silver Nitrate	D	A	A	D	A		B	A	A	A	
Silver Plating Sol.		A	A					A	A		
Soap Solutions (Stearates)	A	A	A	A	A		A	A	A		
Sodium Acetate	C	B	B	B	B	B	A	A	A	A	A
Sodium Aluminate	C	A	B	B	B	B	A	A	A	A	
Sodium Benzoate		B	B	B			A	A	A	A	A
Sodium Bicarbonate	C	B	A	B		A	A	A	A	A	A
Sodium Bichromate		B	B				A		A	A	
Sodium Bisulfate 10%	D	A	A	B		B	A	A	A	A	A
Sodium Bisulfite 10%	D	A	B	B	B	B	A	A	A	A	A
Sodium Borate	C	B	B	B		B	A	A	A	A	A
Sodium Bromide 10%	C	B	B	B		B		A	A	A	A
Sodium Carbonate (Soda Ash)	B	A	A	B	B	B		A	A	A	A
Sodium Chlorate	C	B	B	C	B	B		B	A	A	A
Sodium Chloride	C	B	A	A	B	B		A	A	A	A
Sodium Chromate	B	A	B	B		B			A	A	
Sodium Citrate		B	B					A	A	A	
Sodium Cyanide	B	A	A	B		B		A	A	A	
Sodium Ferricyanide		A	A	B				A	A	A	A
Sodium Fluoride	D	B	A	B		B	A	A	A	D	A
Sodium Hydroxide, 20% Cold	A	A	B	A		B	A	A	A	D	A
Sodium Hydroxide, 20% Hot	B	A	A	A		B		A	A	D	A
Sodium Hydroxide, 50% Cold	A	A	A	A		B		A	A	D	A
Sodium Hydroxide, 50% Hot	B	A	A	B				A	A	D	A
Sodium Hydroxide, 70% Cold	A	A	B	A		B		A	A	D	A
Sodium Hydroxide, 70% Hot	B	A	B	B		B		A	A	D	A
Sodium Hypochlorite (Bleach)	D	D	C	D	A			A	A	A	A
Sodium Hyposulfite		B	B	B				A	A	A	
Sodium Lactate		A	A	B				A	A	A	
Sodium Metaphosphate	B	B	B		A	B		A	A	A	
Sodium Metasilicate Cold	C	A	A	A				A	A	A	
Sodium Metasilicate Hot	D	A	A	A	A			A	A	A	
Sodium Nitrate	B	A	A	B	B	B	D		A	A	A
Sodium Nitrite		B	B	C	B	A		B	A	A	A
Sodium Perborate	B	B	B	B	B	A		A	A	A	
Sodium Peroxide	C	B	B	B	B	A		A	A	A	

A = Excellent

B = Fair

C = Poor

D = Not Recommended

Chemicals	Body/Trim				Seats/Packing						
	Carbon Steel	316 Stainless Steel	Alloy 20	Monel	Hastelloy C	EPDM	PEEK	Graphite	PTFE	Reinforced (PTFE)	UHMWPP
Sodium Phosphate	C	B	B	B	B	A		A	A	A	A
Sodium Phosphate, Di-basic	C	B	B	B	B	A		A	A	A	A
Sodium Phosphate, Tri-basic	C	B	B	B	B	A		A	A	A	A
Sodium Polyphosphate		B	B	B	B	A		A	A	A	A
Sodium Salicylate		A	A					A	A	A	
Sodium Silicate	B	B	B	B		B	A	A	A	A	A
Sodium Silicate, Hot	C	B	B	B		B	A	A	A	A	A
Sodium Stearate		B							A	A	
Sodium Sulfate	B	A	A	A		A		A	A	A	A
Sodium Sulfide	B	B	B	B		B		A	A	A	A
Sodium Sulfite		A	A	B	B	B		A	A	A	A
Sodium Tetraborate		A	A			B		A	A	A	
Sodium Thiosulfate	B	B	B	B		A		A	A	A	
Soybean Oil	C	A	A	A		B	A	A	A	A	A
Stannous Chloride	D	B	A	C					A	A	
Stannous Fluoride		B	B						A	D	
Starch	C	B	A	A		C	A	A	A	A	A
Steam (212°F)	A	A	A	B		B	A	A	A	A	A
Stearic Acid	C	B	B	B	A	B		A	A	A	A
Styrene	A	A	A	B	A	D	A	A	A	A	
Succinic Acid	B	B	B						A	A	
Sulfate, Black Liquor	C	B	B	B		B		A	A	A	
Sulfate, Green Liquor	C	B	B	B					A	A	A
Sulfate, White Liquor	C	B	D	C					A	A	A
Sulfite Liquors	D	B		D						A	A
Sulfonic Acid		B		B						A	A
Sulfur	C	B	A	B		B	A	A	A	A	A
Sulfur Chlorides	D	D	A	B		C			A	A	A
Sulfur Dioxide, Dry	B	A	B	B	A	A			A	A	A
Sulfur Dioxide, Wet		A	B	A	B	B			A	A	A
Sulfur Hexafluoride			A	A					A	A	D
Sulfur, Molten	C	B	A	D	B	B	D		A	A	A
Sulfur Trioxide	B	B	B		B				D	A	A
Sulfur Trioxide, Dry	B	B	B	B	B	B			D	A	A
Sulfuric Acid (0-7%)	D	B	C	C						A	A
Sulfuric Acid (7-40%)	D	D	B	C						A	A
Sulfuric Acid (40-75%)	D	D	C	B			B			A	A
Sulfuric Acid (75-95%)	C	D	B	D						A	A
Sulfuric Acid (95-100%)	C	C	D	B						A	A
Sulfurous Acid	D	B	B	D	B	C			A	A	A
Synthesis Gas	B	B	B	A						A	A

Chemicals	Body/Trim					Seats/Packing					
	Carbon Steel	316 Stainless Steel	Alloy 20	Monel	Hastelloy C	EPDM	PEEK	Graphite	PTFE	Reinforced (PTFE)	UHMWP
Tall Oil	B	B	B	B	A	D	A	A	A	A	
Tannic Acid	C	B	B	B	B	B	A	A	A	A	A
Tartaric Acid	D	A	A	B	B	B		A	A	A	A
Tetraethyl Lead	C	B	B	A			A	A	A	A	
Thioglycolic Acid		B	B					A	A		
Toluol (Toluene)	A	A	A	A	A	D	A	A	A	A	D
Toluene Diisocyanate		A	A					A	A		
Transformer Oil	A	A	A	A			A	A	A	A	C
Tributyl Phosphate	A	A	A	A		B		A	A	A	
Trichlorethylene	B	B	B	B	A	D		A	A	A	D
Trichloroacetic Acid		D	B	B	A			A	A	C	
Triethanolamine		B	B	B	A	B		A	A	A	C
Triethylamine		B	B		A			A	A		
Triethylene Glycol	C	B	B	B				A	A		
Trisodium Phosphate		B	B		A	B		A	A	A	A
Tung Oil	B	A	A	C	A	D	A	A	A	A	
Turpentine	B	B	B	B	A	D	A	A	A	A	D
Urea	C	B	B	B	A	B	A	A	A	A	A
Uric Acid		A	A		A		A	A	A	A	

A = Excellent

B = Fair

C = Poor

D = Not Recommended

Chemicals	Body/Trim					Seats/Packing					
	Carbon Steel	316 Stainless Steel	Alloy 20	Monel	Hastelloy C	EPDM	PEEK	Graphite	PTFE	Reinforced (PTFE)	UHMWP
Varnish	C	A	A	A	A	D	A	A	A	A	A
Vegetable Oils	B	A	A	B	A	D		A	A	A	A
Vinegar	D	A	A	B	A	A	A	A	A	A	A
Vinyl Acetate		B	B	B	A	A	A	A	A	A	A
Vinyl Chloride, Dry	A	B	B	B					A	A	
Water, Deionized	D	A	A	A					A	A	
Water, Distilled	D	A	A	A	A	B	A	A	A	A	A
Water, Fresh	C	A	A	A	A	B	A	A	A	A	A
Water, Sea	D	B	B	A					A	A	
Water, Acid Mine	D	B		D	C	A	A	A	A	A	A
Wax Emulsions	A	A	A	A					A	A	
White Water	C	B	B	C					A	A	
Xylene (Xylol), Dry	B	A	A	A	A	D	A	A	A	A	D
Zinc Acetate		B							A	A	
Zinc Chloride	D	D	A	B					A	A	
Zinc Bromide		B	B	B	A	B		A	A	A	
Zinc Hydrosulfite	A	A	A	B	A	A			A	A	
Zinc Sulfate	D	B	A	B	A	A	A	A	A	A	A

Exploded View 1/2" - 6"

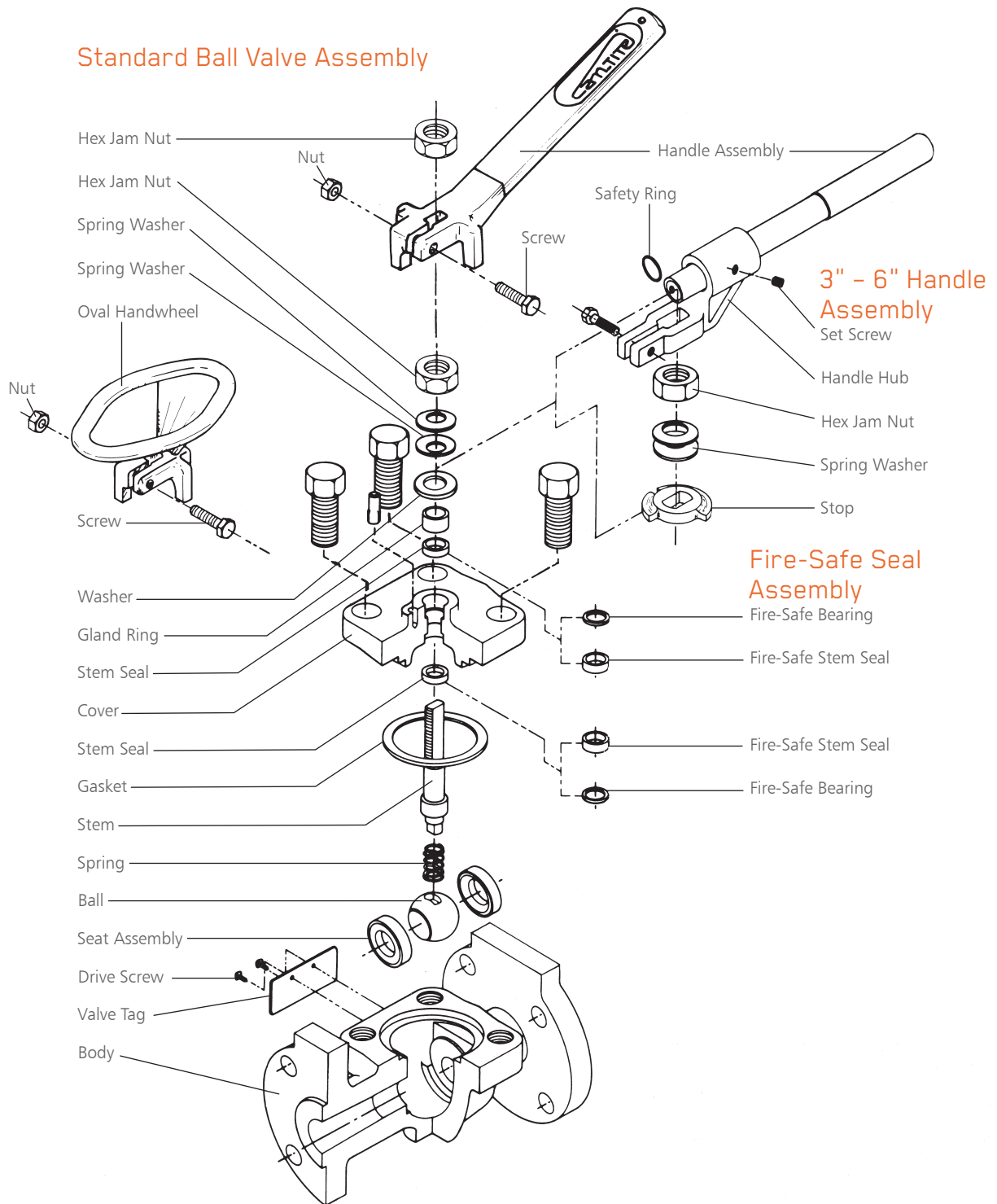

Standards

Compliance With National Standards

Cam-Tite® Ball Valves are designed to the following ASME specifications:

ASME B2.1	Pipe Threads
ASME B16.5	Flanges and Flanged Fittings
ASME B16.10	Face-to-Face and End-to-End Dimensions of Valves
ASME B16.11	Socketweld and Threaded Fittings
ASME B16.25	Buttweld Ends
ASME B16.34*	Flanged, Threaded and Weld End Valves
ASME B31.1	Power Piping
ASME B31.3	Chemical Plant and Petroleum Refinery Piping

*Compliance to ASME B16.34 is dependent on the materials of construction selected and the testing specified for each application. Consult the factory for further details.

All standard Cam-Tite Ball Valves are tested and tagged in accordance with the following specifications:

MSS-SP-25	Marking System for Valves
MSS-SP-72	Ball Valves for General Service

In addition, Cam-Tite® Ball Valves can be furnished in accordance with the special requirements of the following specifications:

ASME B31.3	Category M Service
API 598	Valve Inspection and Testing
API 607	Firetesting for Soft Seated Quarter Turn Valves
Chlorine Institute Pamphlet 6	Ball Valves for Dry Chlorine Service
NACE Standard MR01-75	Materials for Oilfield Equipment

Material Standards

Cam-Tite® body and bonnet investment castings are in accordance with one of the following standards:

Carbon Steel	ASTM A216 GR WCB (Low Temperature: -20°F / -29°C)
Carbon Steel	ASTM A352 GR LCB (Low Temperature: -50°F / -45°C)
Carbon Steel	ASTM A352 GR LC-1 (Low Temperature: -75°F / -60°C)
316 Stainless Steel	ASTM A351 GR CF8M
316 L Stainless Steel	ASTM A351 GR CF3M
Alloy 20	ASTM A351 GR CN7M
Monel	ASTM A494 GR M-35-1
Hastelloy C	ASTM A494 GRs CW-6M or CW-2M
Inconel	ASTM A494 GR CY-40
Nickel	ASTM A494 GR CZ-100
Titanium	ASTM B367 GR C3

Default Cam-Tite® Ball Valve cover bolting is in accordance with the following standards:

Carbon Steel	ASTM A193 GR B7
Stainless Steel	ASTM A193 GR B8

Certified Material Test Reports (CMTRs) can be supplied on the above materials. Contact Engineered Valves for additional information on materials not listed.

Ordering Information

How to Order Cam-Tite® Ball Valves

The Cam-Tite Ball Valve is designated by a series of configuration numbers that define the valve size (Block A); base body construction (Blocks B1–B4); cover type (Block C); ball / stem material (Block D1); seat material (Block S1); stem seal / gasket materials (Blocks S2-S3); actuation (Blocks N1–N6); and additional options (Blocks D3-L).

By selecting the proper code for each of the required blocks, the configuration number can be specified. For a complete listing of the available codes, see pages 49 and 50.

BLOCK	FEATURES	Example 1	Example 2
A	Size	2	1
B1	Body	3010	3215
B2	Buttweld Schedule		
B4	Drain Port		
C	Cover	1	1
D1	Ball / Stem Material	T1	T3
S1	Seat Material	ST1	ST2
S2	Stem Seal / Gasket Material	SL1	SL2
S3	Gasket material / Bellows Only		
N1	Actuation		
N2	Actuator Mode		
N3	Actuator Springs		
N4	Fail Position		
N5	Solenoid Valve		
N6	Limit Switches		
D3	Exterior Trim		
D2	Extended Stem		
D4	Optional Fasteners		
E	Handle Options		HD3
F	Locking Device		LDS
K	Optional Preparations		
L	Nace Service		

Example 1: 2-3010-1-T1-ST1-SL1

2" ANSI Class 150# Flanged Carbon Steel Ball Valve with Standard Cover, 316 Stainless Steel Trim, PTFE Seats and Seals, and Hand Lever Operator.

Example 2: 3215-1-T3-ST2-SL2-HD3-LDS

1" ANSI Class 150-300# Socketweld End Alloy 20 Ball Valve with Standard Cover, Alloy 20 Trim, RTFE Seats and Seals, and Oval Handwheel Operator with Stainless Steel Locking Device.

Figure Numbers: Bodies, Covers and Trim

Size Range

Cam-Tite® Ball Valves (Block A)

Code	Valve Size
0.5	½"
0.75	¾"
1	1"
1.5	1 ½"
2	2"
3	3"
4	4"
6	6"

Flanged Ends

Cam-Tite® Ball Valves (Block B1)

Code	Body Material
150# 3010	Carbon Steel WCB
3110	Carbon Steel LCB
3810	Carbon Steel LC-1
3011	316 Stainless Steel
3211	Alloy 20
3311	Monel
3411	Hastelloy C
3511	Nickel
3611	Titanium
3711	Inconel

300# 3018	Carbon Steel WCB
3118	Carbon Steel LCB
3818	Carbon Steel LC-1
3019	316 Stainless Steel
3219	Alloy 20
3319	Monel
3419	Hastelloy C
3519	Nickel
3619	Titanium
3719	Inconel

600# 3026	Carbon Steel WCB
3126	Carbon Steel LCB
3826	Carbon Steel LC-1
3027	316 Stainless Steel
3227	Alloy 20
3327	Monel
3427	Hastelloy C
3527	Nickel
3627	Titanium
3727	Inconel

Buttweld Ends

Cam-Tite® Ball Valves (Block B1)

Code	Body Material
150# 3012	Carbon Steel WCB
3112	Carbon Steel LCB
3812	Carbon Steel LC-1
3113	316L Stainless Steel
3213	Alloy 20
3313	Monel
3413	Hastelloy C
3513	Nickel
3613	Titanium
3713	Inconel

Buttweld Ends

Cam-Tite® Ball Valves (Block B1)

Code	Body Material
300# 3020	Carbon Steel WCB
3120	Carbon Steel LCB
3820	Carbon Steel LC-1
3121	316L Stainless Steel
3221	Alloy 20
3321	Monel
3421	Hastelloy C
3521	Nickel
3621	Titanium
3721	Inconel

600# 3028	Carbon Steel WCB
3128	Carbon Steel LCB
3828	Carbon Steel LC-1
3129	316L Stainless Steel
3229	Alloy 20
3329	Monel
3429	Hastelloy C
3529	Nickel
3629	Titanium
3729	Inconel

Socketweld Ends

Cam-Tite® Ball Valves (Block B1)

Code	Body Material
150#-300# 3014	Carbon Steel WCB
3114	Carbon Steel LCB
3814	Carbon Steel LC-1
3115	316L Stainless Steel
3215	Alloy 20
3315	Monel
3415	Hastelloy C
3515	Nickel
3615	Titanium
3715	Inconel

600# 3022	Carbon Steel WCB
3122	Carbon Steel LCB
3822	Carbon Steel LC-1
3123	316L Stainless Steel
3223	Alloy 20
3323	Monel
3423	Hastelloy C
3523	Nickel
3623	Titanium
3723	Inconel

Threaded Ends

Cam-Tite® Ball Valves (Block B1)

Code	Body Material
150#-300# 3016	Carbon Steel WCB
3116	Carbon Steel LCB
3816	Carbon Steel LC-1
3117	316L Stainless Steel
3217	Alloy 20
3317	Monel
3417	Hastelloy C
3517	Nickel
3617	Titanium
3717	Inconel

Threaded Ends

Cam-Tite® Ball Valves (Block B1)

Code	Body Material
600# 3024	Carbon Steel WCB
3124	Carbon Steel LCB
3824	Carbon Steel LC-1
3125	316L Stainless Steel
3225	Alloy 20
3325	Monel
3425	Hastelloy C
3525	Nickel
3625	Titanium
3725	Inconel

Buttweld Schedule (Block B2)

Code	End Preparation
SCH10	Schedule 10
SCH40	Schedule 40
SCH80	Schedule 80

Drain Port (Block B4)

Code	Drain Port
D	Body Port with Plug

Valve Length

Code	Valve Length
GV	ASME B16.10 Globe Valve Length

Cover (Block C)

Code	Cover
1	Standard
2	Extended
3	Severe Service
4	Severe Service with Lantern Ring
5	Bellows Seal / Manual
6	Bellows Seal / Actuated
7	Fire Safe Bellows Seal / Manual
8	Standard with Internals Cage
9	Extended with Internals Cage
10	Severe Service with Internals Cage
11	Severe Service with Lantern Ring and Internals Cage
12	Body Only

Ball / Stem (Block D1)

Code	Ball / Stem Material
T1	316SS / 316SS
T2	Monel / Monel
T3	Alloy 20 / Alloy 20
T4	Hastelloy C / Hastelloy C
T5	Hastelloy C / Monel
T6	Monel / Hastelloy C
T7	316SS / Hastelloy C
T8	Inconel 625 / Inconel 625
T9	Ceramic / 316SS
T10	Ceramic / Monel
T11	Ceramic / Alloy 20
T12	Ceramic / Hastelloy C
T13	Nickel / Nickel
T14	Titanium / Titanium
T15	Tantalum / Hastelloy C
T16	304SS / 304SS
T17	Alloy 20 / Inconel 718
T18	Tantalum / Nickel
T19	316SS / 17-4 PHSS

Figure Numbers: Actuators, Actuator Accessories and Bonnet Options

Seat Material (Block S1)

Code	Seat Material
ST1	PTFE
ST2	RTFE
ST3	Fire-Safe RTFE
ST4	Fire-Safe PTFE
ST5	UHMW Polyethylene
ST6	G2000 PEEK
ST7	G3000 PEEK
ST9	PTFE / Carbon Filled
ST10	Fire-Safe Design PTFE / Carbon Filled
ST11	Fire-Safe Design PTFE (Carbon Filled) RTFE
ST12	PTFE / CAF FILLED

Stem Seal / Gasket Material (Block S2)

Code	Stem Seal / Gasket Material
SL1	PTFE / PTFE
SL2	RTFE / RTFE
SL3	UHMWP / UHMWP
SL4	Graphite / Graphite
SL5	Graphite / PTFE
SL6	Graphite / RTFE
SL7	Graphite / G2000 PEEK
SL8	Graphite / G3000 PEEK
SL11	PTFE/TFM1600

Gasket Material / Bellows Only (Block S3)

Code	Gasket Material
G1	PTFE
G2	RTFE
G3	UHMWP
G4	Graphite
G5	G2000 PEEK
G6	G3000 PEEK

Actuator (Block N1)

Code	Actuator Model
C15	C15 Compact Actuator
C20	C20 Compact Actuator
C25	C25 Compact Actuator
C30	C30 Compact Actuator
C35	C35 Compact Actuator
C45	C45 Compact Actuator
C60	C60 Compact Actuator
C75	C75 Compact Actuator

Compact Actuator Mode (Block N2)

Code	Actuator Model
DA	Double Acting
SR	Spring Return

Compact Actuator Mode (Block N3)

Code	Actuator Springs
1A	1A
1B	1B
2	2
2A	2A
2B	2B
2C	2C
3	3

Compact Actuator

Failure Position (Block N4)

Code	Failure Position
FO	Fail Open
FC	Fail Closed

Solenoid Valve (Block N5)

Code	Description
SV1	Asco EF8320G184
SV2	Asco EF8320G184
SV3	Asco EF8345G1
SV4	Asco EF8345G1

Actuator Limit Switches (Block N6)

Code	Description
LS1N	WESTLOCK 1040NFC2A2M0200 / 2SPDT / NEMA 4, 4X
LS2N	WESTLOCK 1040NBY2A2M0200 / 2SPDT / NEMA 4, 4X / BEACON
LS3N	WESTLOCK 2004NBY2A2M0200 / 2SPDT / NEMA 4, 4X
LS4N	WESTLOCK 2007NBY2B2M0200 / 2SPDT / NEMA 4, 4X, 7
LS9N	WESTLOCK 2007NBY2E2M0200 / 2SPDT / NEMA 4, 4X, 7 LESS SOL.
LS10N	WESTLOCK 9479NBY2B2M0600 / 2SPDT / NEMA 4, 7, 9
LS15N	WESTLOCK 9358NBY2A2M0600 / 2SPDT / NEMA 4, 4X

Exterior Trim (Block D3)

Code	Trim Material
ET1	Stainless Steel Gland, Bellevilles, Washers and Nuts
ET2	Stainless Steel Gland, Washers and Nuts / Inconel Bellevilles
ET3	Inconel Gland, Washers, Nuts and Bellevilles
ET4	Hastelloy Gland, Washers and Nuts / Inconel Bellevilles

Extended Stem (Block D3)

Code	Extension Type
EXTSP	Stem Extension w/o Bracket
EXTSPBK	Stem Extension w/ Bracket

Optional Fasteners (Block D4)

Code	Material
BOLTING	
B1	A193 GR B7
B2	A320 GR L7
B3	A193 GR B8
B4	Inconel
B5	Hastelloy
B6	Alloy 20
B7	A193 GR B7 / PTFE Coated
B8	Monel
B9	A193 GR B7M

Optional Fasteners (Block D4)

Code	Material
STUDS / NUTS	
SN1	A193 GR B7 / A194 GR 2H
SN2	A320 GR L7 / A194 GR L7
SN3	A193 GR B8 / A194 GR B8
SN4	Inconel / Inconel
SN5	Hastelloy / Hastelloy
SN6	Alloy 20 / Alloy 20
SN7	A193 GR B7 / PTFE Coated
SN8	Monel / Monel

Handle Options (Block E)

Code	Material
HANDLE	
HD1	Stainless Steel
OVAL HANDWHEEL	
HD2	Carbon Steel
HD3	Stainless Steel
CHAINWHEEL	
HD5	Carbon Steel Horizontal Line
HD6	Carbon Steel Vertical Line
HD7	Stainless Steel Horizontal Line
HD8	Stainless Steel Vertical Line

Locking Device (Block F)

Code	Material
LDS	Stainless Steel

Optional Preparation (Block K)

Code	Preparation
CLV	Chlorine / Vented Body
HF	Hydrofluoric Acid
HFV	HF Acid / Vented Body
OX	Oxygen
PHO	Phosgene
PHOV	Phosgene / Vented Body
TOB	Tobacco Service (No PTFE)
TOBV	Tobacco Service / Vented
V	Vented Body
NL	No Lubricant
VNL	Vented Body / No Lubricant
VB	Vented Ball
CLN	Cleaned and bagged
CLNV	Vented body / cleaned and bagged

Nace Service (Block L)

Code	Nace Service
NACE1	Nace 1 Service (Above ground, uninsulated)
NACE2	Nace 2 Service (Above ground, insulated)
NACE3	Nace 3 Service (Buried)

Visit our website at

www.engvalves.com

ITT Engineered Valves: 65 years of Providing Quality, Innovative Solutions

ITT Engineered Valves has earned the reputation for delivering the highest quality, innovative valve solutions for a wide range of industrial fluid control needs. These best in-class quality valves have been the foundation for industries such as Mining, Power Generation, Pollution Control, Pulp and Paper, Chemical Processing, Water Treatment, Pharmaceutical, Food and Beverage, and Bio-Processing.

Through both standard and custom designed valve assemblies, ITT Engineered Valves is your partner in providing the best quality and value engineered solutions for your unique flow control needs.

1. Dia-Flo® Diaphragm Valves
2. Fabri-Valve® Knife Gate, Slide Gate, Wedge Gate and Custom-Fabricated Valves
3. Cam-Tite® Hazardous and Critical Duty Ball Valves
4. Cam-Line® Plastic Lined Ball Valves
5. Skotch® Burner Safety Shut-Off valves



Lancaster, PA Facility



Amory, MS Facility



ITT Engineered Valves
33 Centerville Road
Lancaster, PA 17603, USA
Tel: +1 (717) 509-2200

Cam-Line, Cam-Tite, Dia-Flo,
EnviZion, Pure-Flo, Skotch

ITT Engineered Valves
1110 Bankhead Avenue
Amory, MS 38821, USA
Tel: +1 (662) 256-7185

Fabri-Valve

ITT Bornemann GmbH
31683 Obernkirchen
Germany
Tel: +49 5724 390-0

EnviZion, Pure-Flo

